

O&M Manual
Revision 3.0

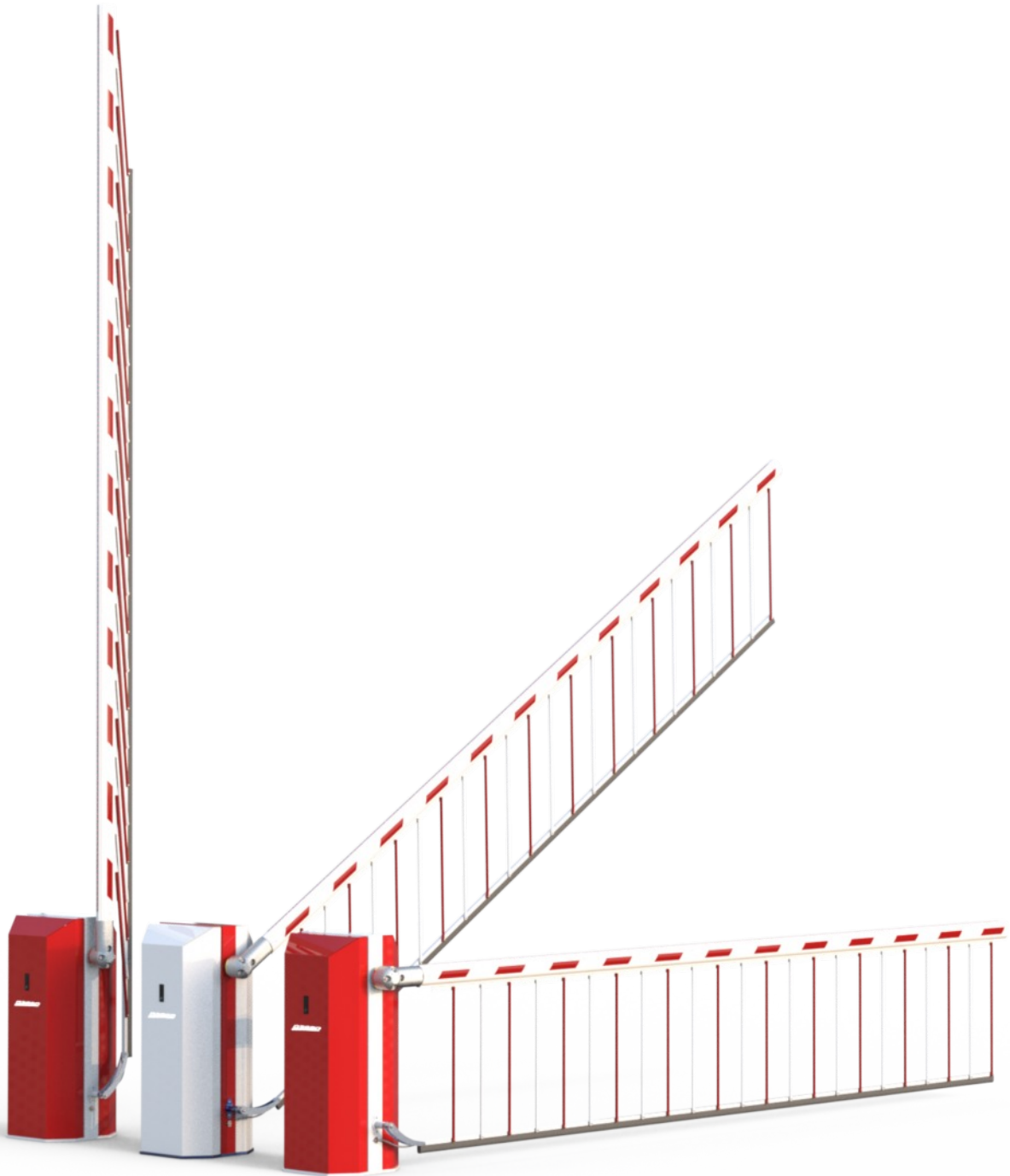

D3850 Automatic Barrier

Maximum span - 9.0m Plain pole, 8.0m Bottom Skirt , 7m Hi-Bar skirt.
100 % Duty cycle

1. Inductions and warnings	Page 03
2. Transport and Handling	Page 04
3. General Description	Page 05
4. General Layout	Page 06
5. General Products	Page 07
6. Installation Guide	Page 08 - 12
7. Connection Guide	Page 13
8. Board Layout	Page 14
9. Terminal Connections	Page 15
10. Board Connections	Page 16 - 17
11. Ancillary Wiring	Page 18
12. Master/Slave	Page 19
13. Initial Setup Prologue	Page 20
14. Set Up	Page 21 - 23
15. Parameters	Page 24
14. Loop Set Up	Page 25
15. Handing Change	Page 26
16. Manual Release	Page 27
17. Fault Diagnostics	Page 28 - 29
18. Commissioning Certificate	Page 30
19. Maintenance	Page 31
20. Safety Devices and Maintenance	Page 32
21. Parts List	Page 33
22. Service Log	Page 34
23. Declaration of Conformity	Page 35
24. Technical Specifications	Page 36

This equipment is part of a large range of traffic flow products. They are designed to be easy to install, as all settings and internal wiring have been completed in our factory. Any of the instructions in this manual should only be carried out by a qualified service engineer or a competent person.

The barriers are ready to bolt down, connect to a single phase power supply and have any pre-cut loops wired into them (Please note that loop detectors are sold separately). The steps must be completed before the power is turned on to prevent accidents.

The following information is a guide only, and whilst we have made every effort to be accurate and correct there may be printing errors which we cannot be held responsible for.

With a correct installation you can expect to enjoy many years of reliable service from this product, we do however recommend that the product has a bi-annual service carried out by a qualified engineer. Please contact our service department to obtain a quote. As we manufacture the products we are best suited to care for your equipment.

Important Safety Notice



Automatic barriers are designed to Control the flow of vehicular traffic only. It can be dangerous to allow the passage of pedestrians and any other self-powered animal or device to utilise this method of access without appropriate warnings and or signage.

It may be necessary for the end user of this product to provide an alternative, safe method of access to cater for the previously mentioned categories.

The end user should fit all necessary signage and warning notices to either side of the gate, which should be visible and clear from all directions of approach.

The product that was shipped to you was designed with a control program to protect all categories from harm or affect this however is only a safety precaution and should not be modified or tampered with by any unauthorised person not sanctioned by the manufacturer.

Please sign and date below to say that you have read and understood this notice before ANY installation work:

/ /20

Information on using this manual



- ✍ Read all information thoroughly
- ✍ Pay attention to all safety advice
- ✍ Be aware of the symbols (shown above right and above left) as they have different meanings. One is an information symbol, the other a warning.
- ✍ There are many artists impressions of the product in this manual you should refer to the images as a guide only. Professional CAD drawings should be used as a reference drawing and nothing else. As before every effort has been made to be 100% accurate in this manual but we cannot make any guarantees.
- ✍ As we constantly innovate our products we may change the quoted spec and any other details that have been documented in this manual so you should always refer to the supplier to see if the manual that was shipped with your product is the latest edition.
- ✍ As with all electrical installations you should use a qualified electrician and obey all of the latest laws and regulations.
- ✍ Be sure to fill out and complete ALL paperwork where instructed as this manual is the equipments log book and maintenance manual.

The "Warnings" leaflet and "Instruction booklet" supplied with this product should be read carefully as they provide important information about safety, installation, use and maintenance.

Scrap packing materials (plastic, cardboard, polystyrene etc) according to the provisions set out by current standards. Keep nylon or polystyrene bags out of children's reach.

Keep the instructions together with the technical brochure for future reference.

This product was exclusively designed and manufactured for the use specified in the present documentation. Any other use not specified in this documentation could damage the product and be dangerous.

The Company declines all responsibility for any consequences resulting from improper use of the product, or use which is different from that expected and specified in the present documentation.

Do not install the product in explosive atmosphere.

The construction components of this product must comply with all applicable regulations.

and subsequent amendments. As for all non-EEC countries, the abovementioned standards as well as the current national standards should be respected in order to achieve a good safety level.

The Company declines all responsibility for any consequences resulting from failure to observe Good Technical Practice when constructing closing structures (door, gates etc.), as well as from any deformation which might occur during use.

The installation must comply with the provisions set out by the applicable regulations and subsequent amendments.

Disconnect the electrical power supply before carrying out any work on the installation. Also disconnect any buffer batteries, if fitted.

Fit an omnipolar or magnetothermal switch on the mains power supply, having a contact opening distance equal to or greater than 3mm.

Check that a differential switch with a 0.03A threshold is fitted just before the power supply mains.

Check that earthing is carried out correctly: connect all metal parts for closure (doors, gates etc.) and all system components provided with an earth terminal.

Fit all the safety devices (photocells, electric edges etc.) which are needed to protect the area from any danger caused by squashing, conveying and shearing, according to and in compliance with the applicable directives and technical standards.

This article describes how your equipment will be delivered to you, specifications on the transportation used and advice including health & safety on movement of the equipment.



The manufacturer will use a qualified transport company to deliver the product conforming to the necessary regulations as detailed below:

- ✘ All drivers are qualified
- ✘ All drivers are tested once yearly (If applicable)
- ✘ All drivers carry risk assessments and method statements (available on request)
- ✘ They are controlled under law to conform as there are no trade regulation standards to comply with

Health and safety Considerations:

Moving Goods Safely (MGS) is a national project involving both the Health and Safety Executive (HSE) and Local Authorities (LA) working in partnership. The project aims to reduce injuries and ill-health arising from the movement of goods from supplier through haulier to the recipient and end user including any home deliveries. The project will focus upon the delivery and collection of goods and the hazards this generates. It covers the main areas that cause the majority of injuries and ill-health to workers, including:

- ✘ Workplace transport;
- ✘ Slips & trips, and;
- ✘ Musculoskeletal disorders (MSD).

The movement of goods presents us, as health and safety regulators, with the challenge of dealing with a huge variety of issues. The commercial organisations involved within the movement of goods are diverse including haulier, third party logistics providers, pallet networks, retailers etc, with some very large companies, thousands of small businesses and the self-employed. The movement of goods is more than just trucks on the road with a large proportion of accidents happening at the delivery/collection sites that are often not directly under the control of the company making the delivery or collection. Communication and cooperation problems can arise due to the many organizations involved in the movement of the goods, and this can also lead to difficulties in effectively managing health and safety.

(Source H&S Executive UK 2008)

The barrier should ALWAYS! be moved with care and attention. The products are very heavy individually as well as a whole. You should not attempt to move this or any other products by unapproved handling methods.

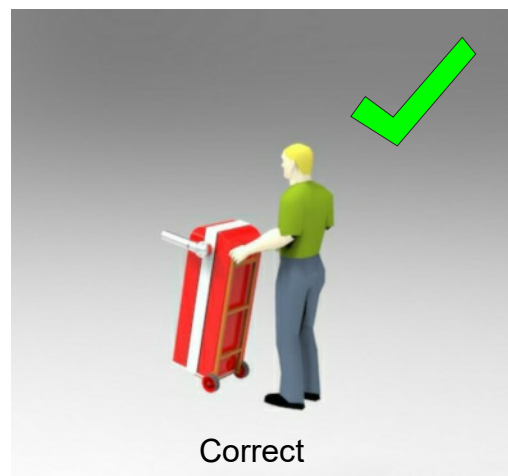
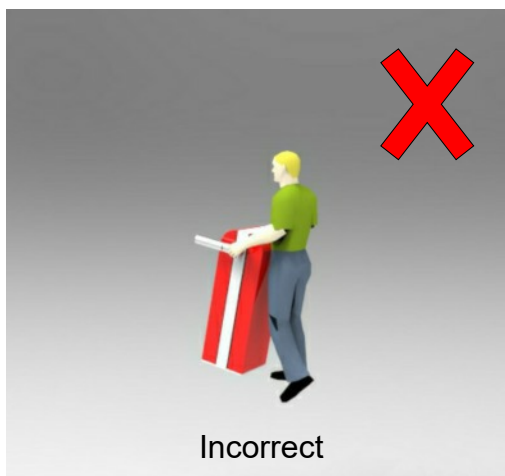

Shown below is a typical installation of a D3850 Automatic barrier for a single entrance. Control setup - A D3850 is a traffic barrier designed for easy access solutions requiring a reliable and simple yet affective way of segregating vehicles or managing traffic flow. With a variety of accessories to suit your individual; needs and specific site requirements.

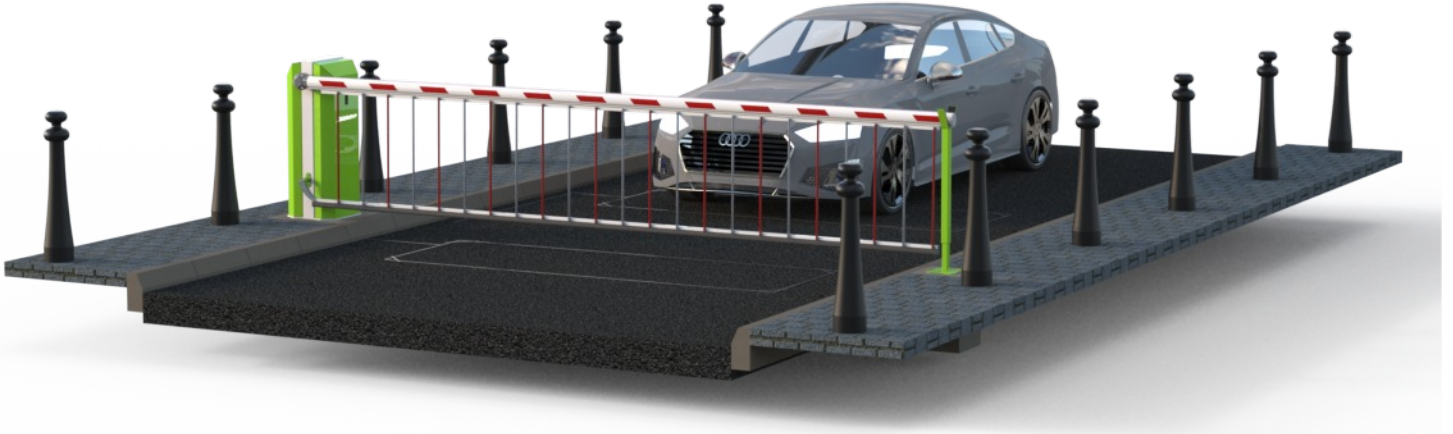

Shown above is one of our D3850 barriers with a fixed bottom skirt these can be fitted with a safety edge if required for extra protection to users and general public. The barrier comes with a few options for accessory poles such as a standard pole, an articulated arm for restricted heights such as underground car parks and a hi-bar skirt for complete coverage

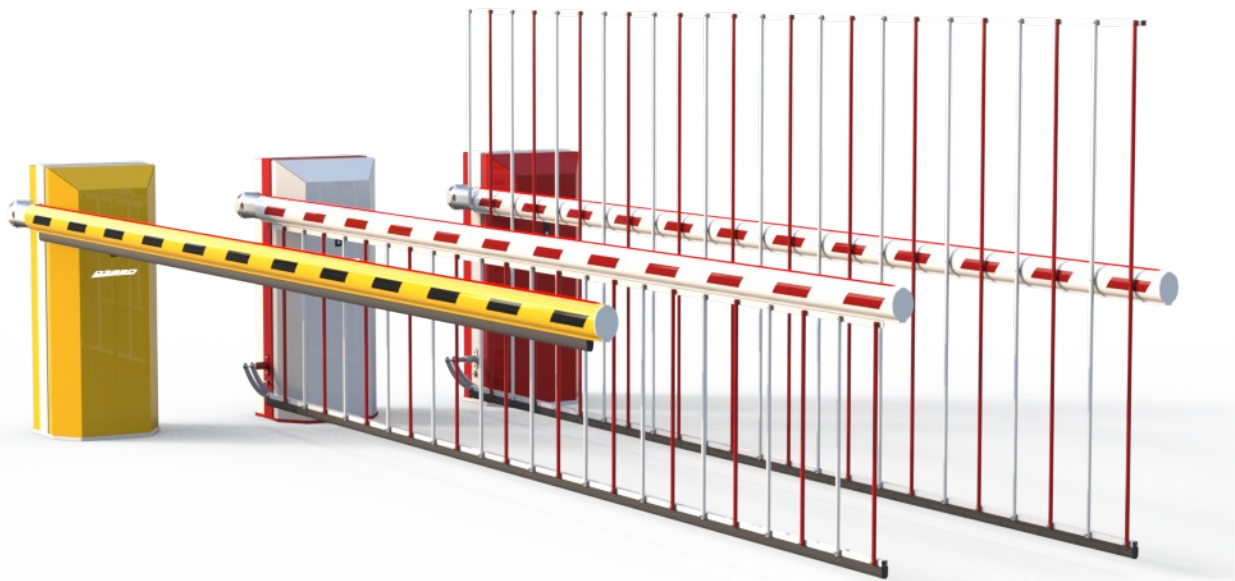

Detailed below is the general layout and dimensions for a typical D3850 layout for base size and depth, pole size and tip base.

RIGHT HANDED BARRIER

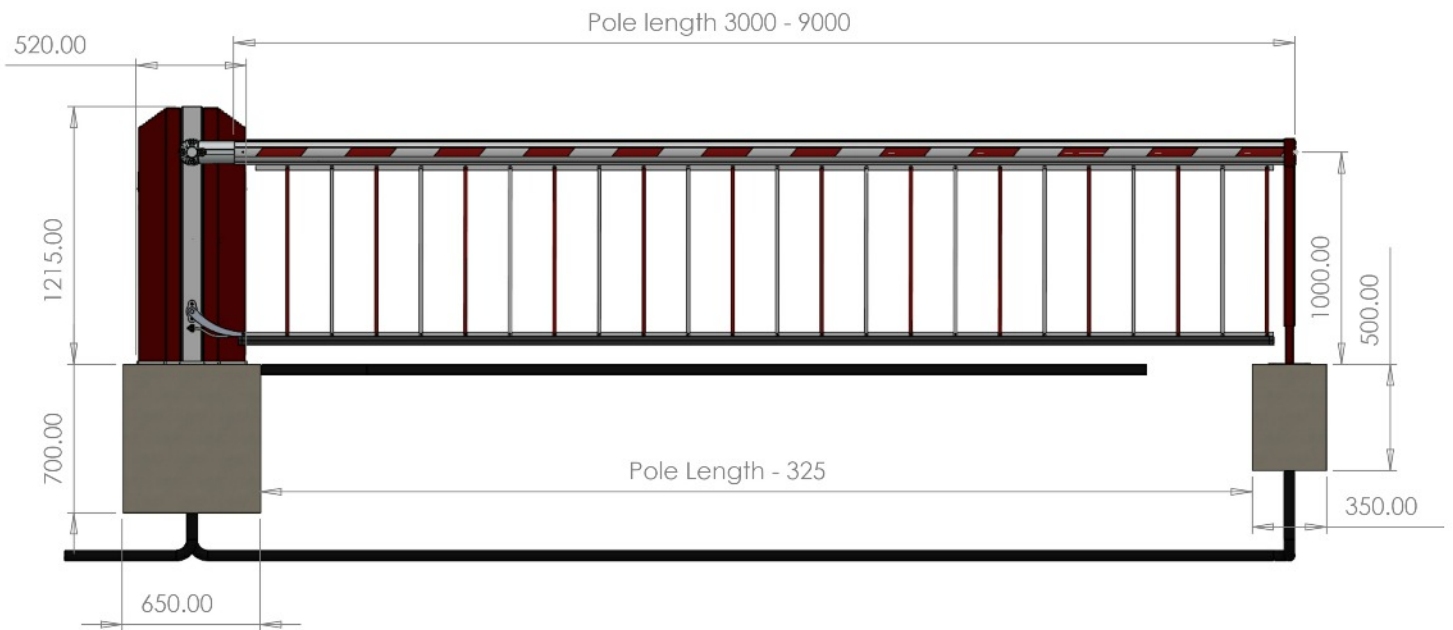

LEFT HANDED BARRIER

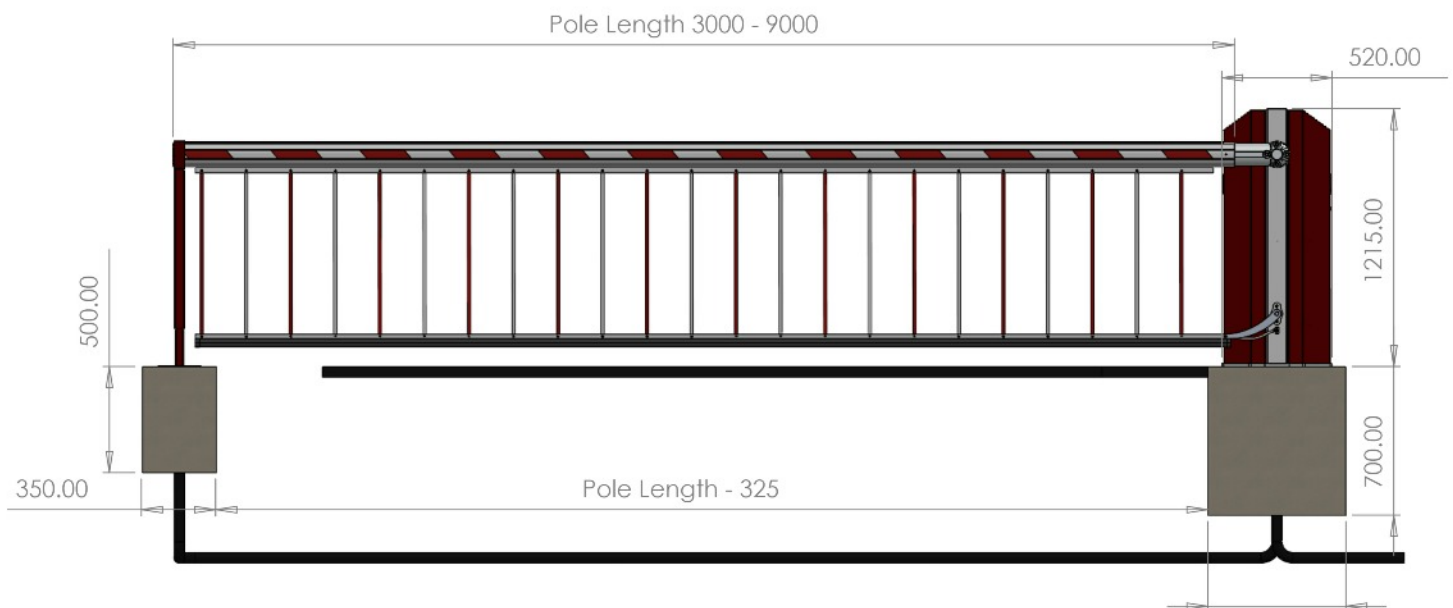

General Barrier Products

On a typical delivery you will receive your D3850 barrier with a tip support, Your pole and a box of fixings as described below



Box of fixings

Your basic box of fixings will include;

- 4 x m16 x 180mm Anchor bolts
- 4 x m16 caps
- 4 x m12 x 125mm Anchor bolts
- 4 x m12 caps
- 2 x m6 x 100mm cap head bolts
- 6 x m6 washers
- 2 x m6 nylocks
- 2 x m6 x 20mm button head bolts
- 1 x Manual winder
- 2 x keys
- 1 x O & M manual



Step 1;

You Must first remove the D3850 barrier Outer covers, Using the provided keys unlock the locks (Fig 1) and press the lock part to unlatch the lock and remove covers (Fig 2) please place these safely to prevent damage.

Fig 1



Fig 2

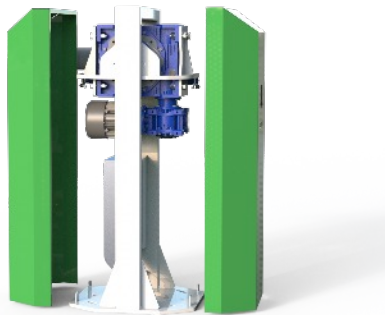

Step 2;

Lower your D3850 barrier onto the prepared foundations and locate centrally (see fig 3) Be aware of your ducting whilst lowering the barrier into place so that you have ease of access for your mains and trigger cables etc.(Fig 4)

Fig 3



Fig 4

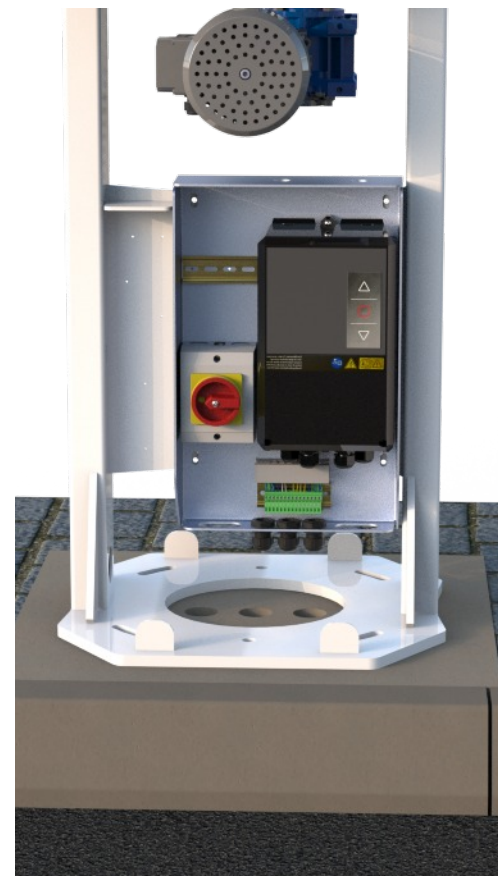

Step 3;

Align your barrier with your tip support using a string line or similar product to ensure correct alignment of barrier/ pole and tip support. (Fig 5)

Fig 5

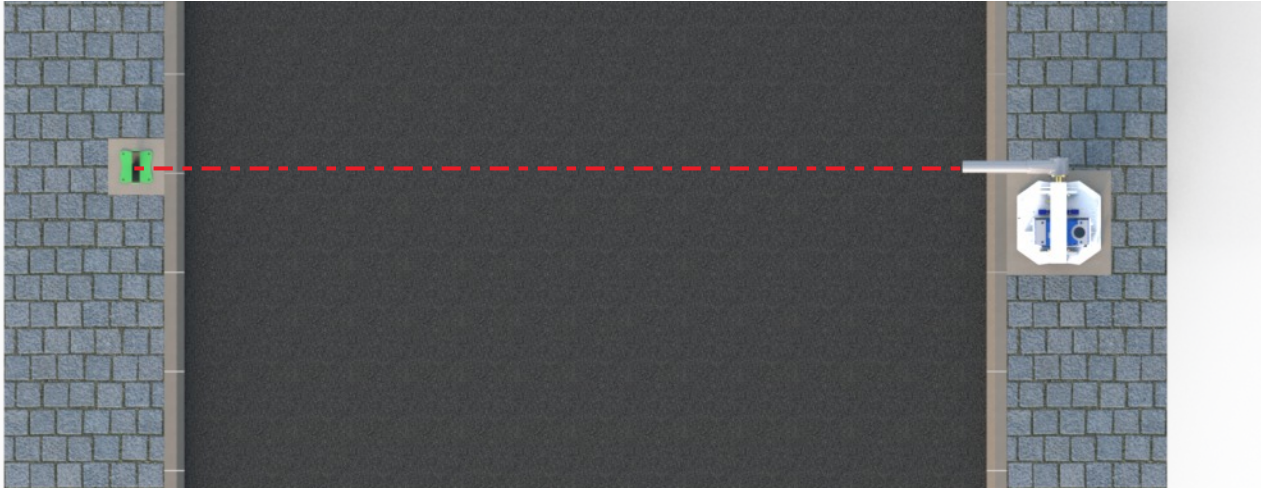

Step 4;

Drill each hole for the barrier central in each slot using an 16mm sds bit and suitable drill, This is to allow full use of the slotted holes should you need a slight adjustment when required. (Fig 6)

When drilled knock the m16 anchor bolts into place using a suitable lump or copper hammer and tighten using a 24mm spanner or socket these should be tightened to 115nm of torque for suitable strength. (Fig 7)

Fig 6

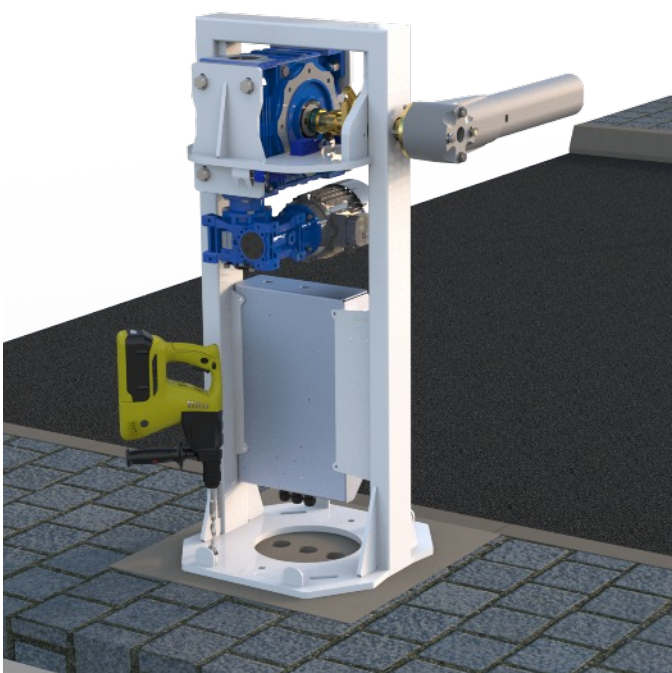

Fig 7

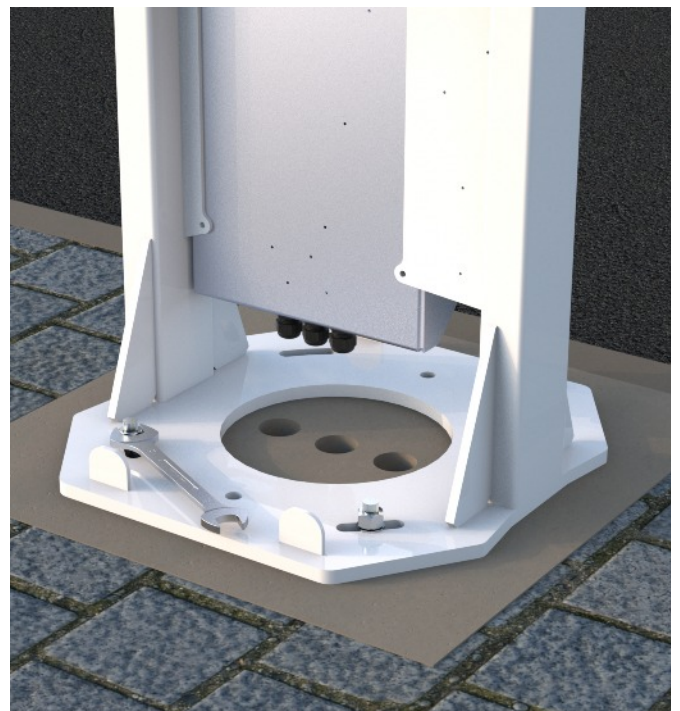

Fig 8

Step 5;

Now that the barrier is bolted you can (using suitable packers) level the product off ensuring the barrier is true and level. (Fig 8) If the barrier needs more than 10mm of packing be sure to grout up with concrete to ensure a stable and neat job.



Step 6;

Adding the pole, Now that your barrier is installed and level, with extreme care the pole can be unwrapped and fitted to the pole arm adapter (fig 9) and fixing using the M6 x x100mm cap head bolts once drilled using a 7mm hss drill bit (fig 10)

Fig 9

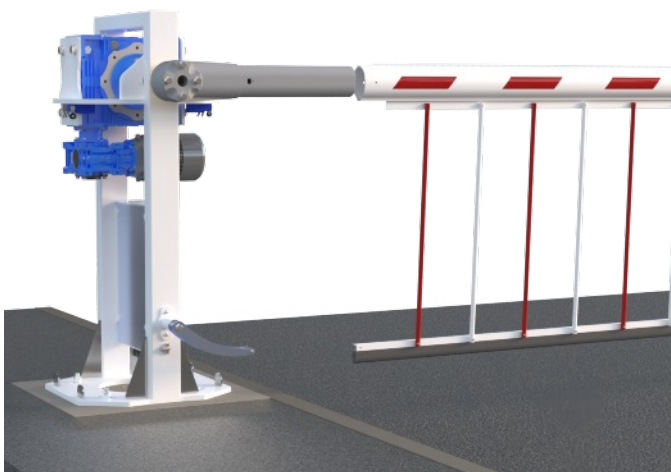

Fig 10



Note, If the pole has LED Lights or a safety edge, this MUST be connected at this point. The LED lights require simply plugging in, the safety edge will need joining. For this we would always recommend the use of gel crimps or other suitable water resistant connectors.

When connecting the pole to the barrier you may have up to three options for different types of connections depending on what's been ordered with your pole. Shown below are the examples of this and a brief guide and diagram to assist you with installation.

Pole With LED Lights

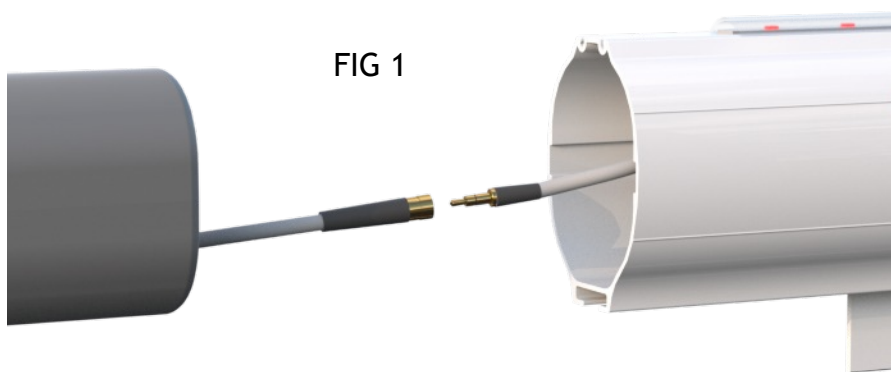

FIG 1

For Poles with No Safety edge fitted directly underneath (This will apply to Skirted Poles Also) Simply to plug together the aux style lead found in the end of your pole and the end of your pole arm adapter. Shown Fig 1

Plain Pole with LED Lights and Safety edge

For Poles that have a safety edge fitted directly underneath the pole you will need to connect the safety edge to the excess cores on the light cable. If the excess cores have been wired from factory then the colours of the two cores will be orange and White as shown in Fig 2. Suitable water resistant connectors should be used, shown is an example of gel crimps being used.

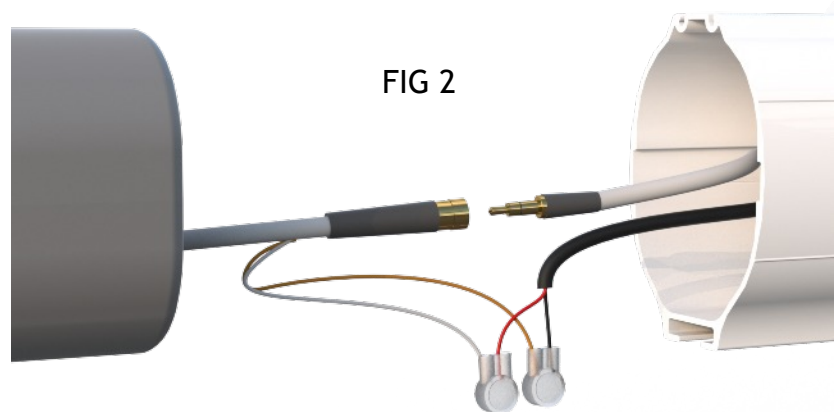

FIG 2

Pole with Skirts and Safety edge



For Skirted Poles with a Safety edge You will need to Fix the Steel cable loop onto the barrier using the Provided M4 Fixings as shown in Fig 3. The safety edge cable can then be routed in to the barrier up in to the control panel. Connect the safety edge into the Feig Panel in Terminals 43 and 44 in the Yellow Terminal blocks. Refer to the Board connections Page

Step 6;

Now your pole is fitted and barrier level the tip support can be bolted down using the m12 fixings supplied (fig 11) and a suitable 12mm sds these can then be tightened using a 19mm spanner or socket (fig 12) and levelled to suit. The height can be adjusted to suit the barrier pole we would advise using a spirit level on the pole and raising the tip support to the under side of the pole before fixing in place. The m6 x 20mm button head bolts can then be drilled, tapped and fixed into place with the provided washers. (Fig 13) Final step is to trim the top of the m12 anchor bolts if required and fit the m12 caps from your fixings box for aesthetic purposes.

Fig 11



Fig 12

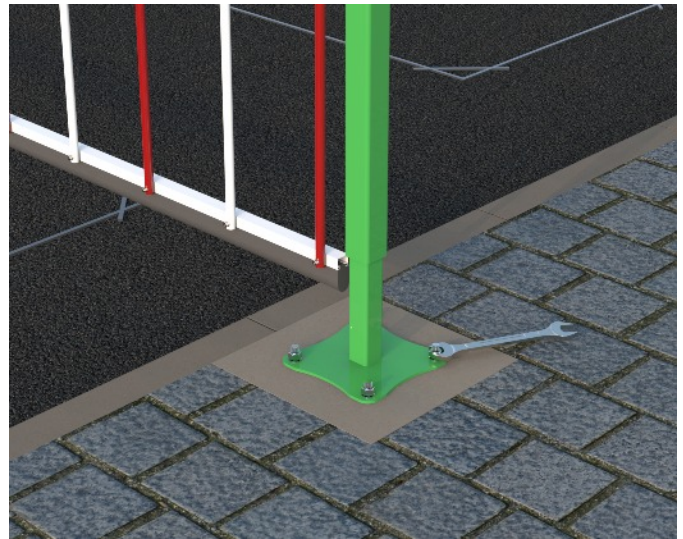

Fig 13

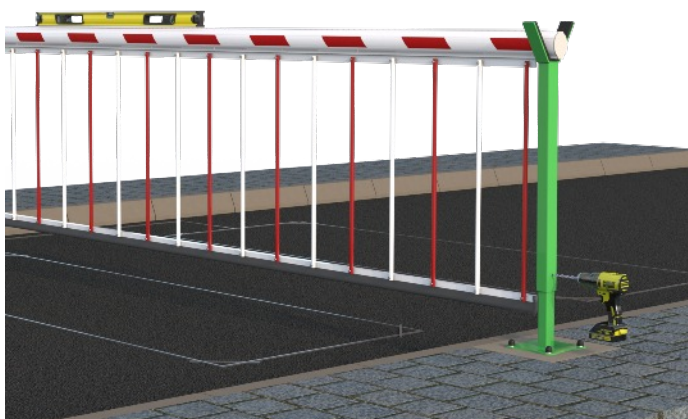
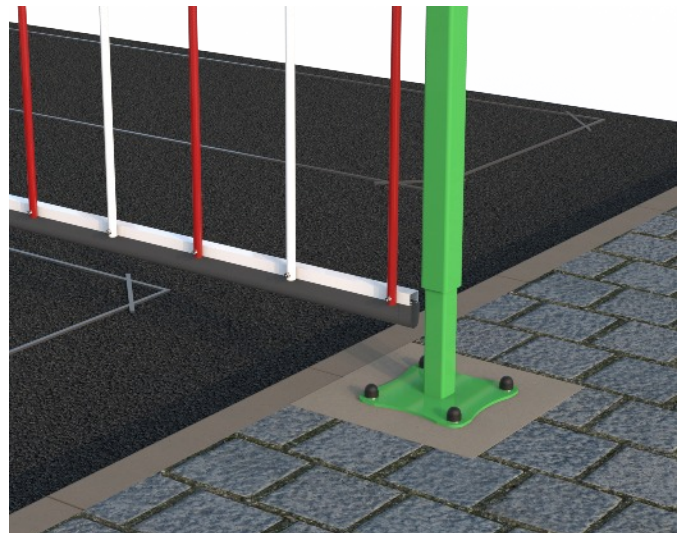
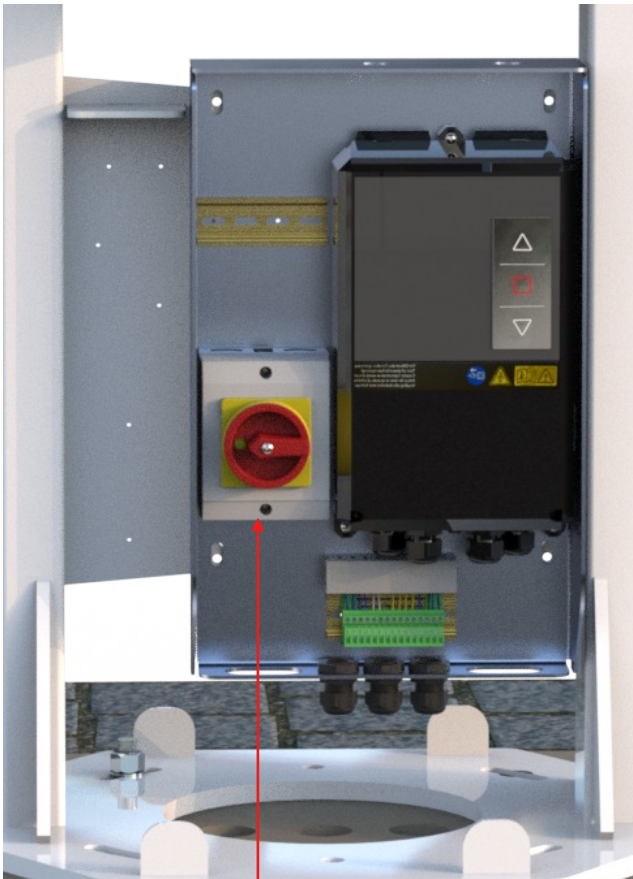

Figure 14



Connecting Up



Now that your barrier is fully installed you will be ready to connect your mains and access cables as well as your loops if required details of these connections are specified over the next few pages along with your positioning and programming guide.

The mains would be the first to connect using a 230v single phase supply at 16 amps this can be easily wired into our rotary isolator (1).

The access controls can be wired directly into the feig controller into the black block which is your common, open close and stop terminals (2).

The loops can be wired direct into the loop card and this added to the feig controller if required (3)

- 1
- 2
- 3

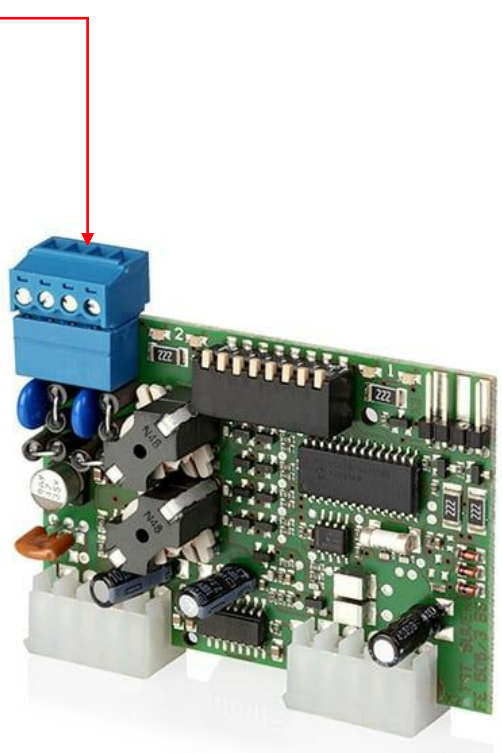

Operation and menu access buttons

Cover removal clips

Cable access glands

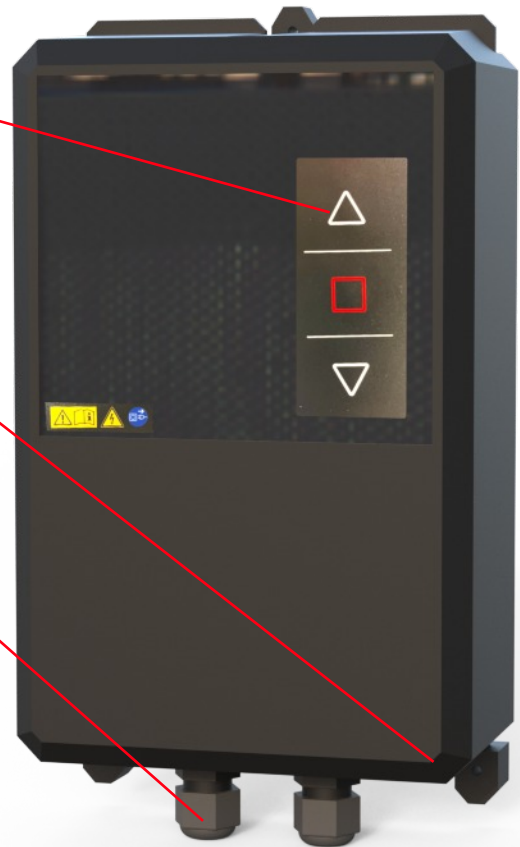

Terminal rail

Traffic light relay

230v accessory supply

Above shows a typical barrier control panel layout which identifies the major components

- A. Loop Channel 1
- A. Loop Channel 1
- B. Loop Channel 2
- B. Loop Channel 2
- 1. Common 24v +
- 2. Stop N/C
- 3. Raise N/O
- 4. Lower N/O
- 5 Safety Edge 8k2
- 6. Safety Edge 8k2
- 7. External 24v +
- 8. External 24v -
- 9. Green Led / Traffic Light
- 10. Red Led / Traffic Light
- 11. Maglock 24v + (Negative to 12)
- 12. 24v + (photocells only)
- 13. 24v - (Photocells only)
- 14. Photocell Common 24v +
- 15. Photocell Contact 24v -

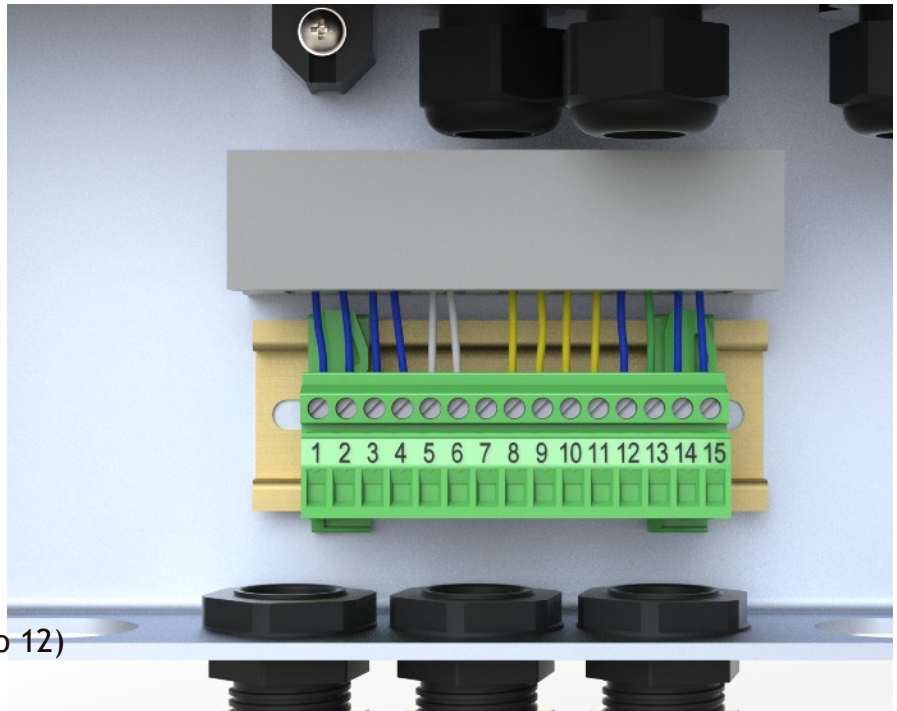

Safety and Auto loop bases

We now use the feig plug in loop cards for convenience of the engineer. If ordered with the product this will arrive with tails pre wired into the green terminal strip.



- 86 Common +24v dc
- 85 Open Dead Man
- 84
- 83 Common +24v dc
- 82 Close Dead Man
- 81
- 76 Common
- 75 Photocell
- 74 Ground -24v dc
- 73 Common +24v dc
- 72 Pedestrian Open (Common from 73 if used)
- 71 Ground -24v dc (Common for opening edge)
- 66 Beacon Sounder (common from 71)
- 65 Open Edge 8k2 Input (common from 71)
- 64
- 63 Ground -24v dc
- 62 Common +24v dc
- 61
- 54 Close Input
- 53 Stop Input (link from 51 if not used)
- 52 Open input
- 51 Common +24v
- 45
- 44 Ground -24v (Common for Close Edge)
- 43 Close Edge Input (Common from 44)
- 42 Common +24v dc
- 41 Stop Input (Link from 42 if not used)
- 36 Ground
- 35 Channel B
- 34 Channel A
- 33 +12v
- 32 Common +24v dc
- 31 Stop input (Link from 32 if not used)
- 22
- 21
- 20
- 12 Green Traffic Light +24v dc
- 11 +24v dc Link
- 10 Red Traffic Light +24v dc

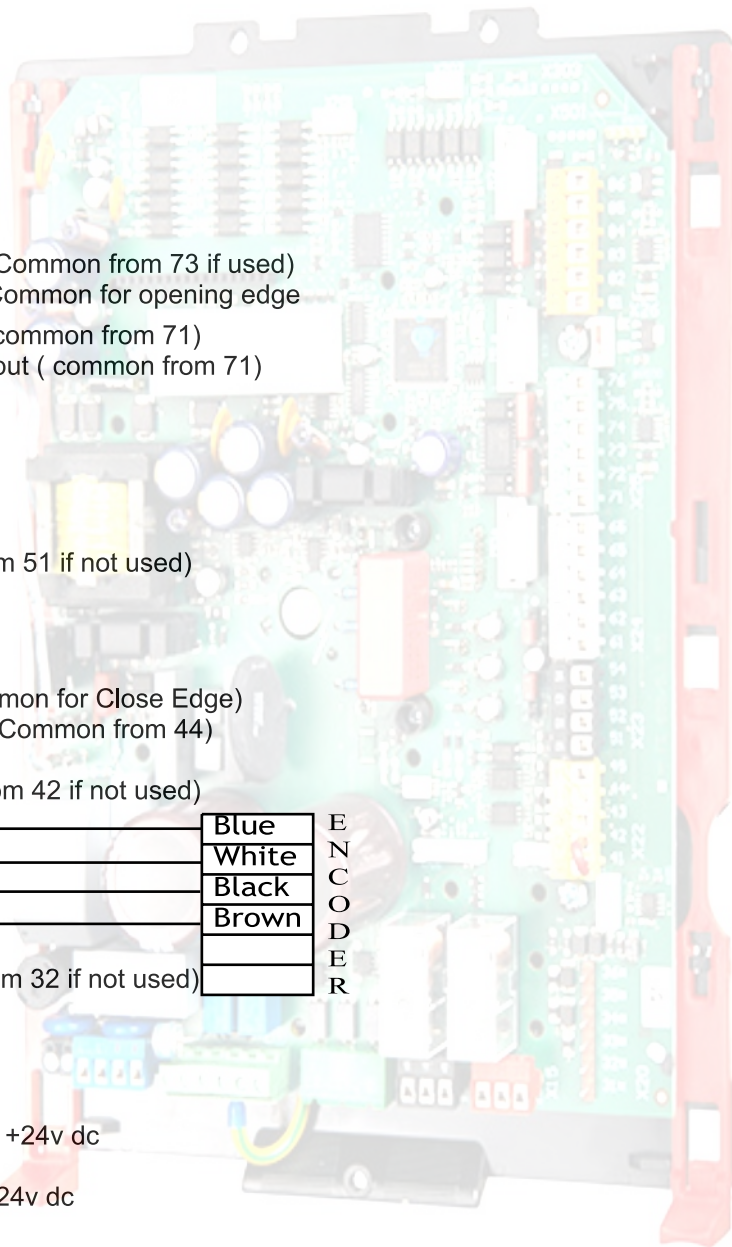

36	Ground	Blue	E
35	Channel B	White	N
34	Channel A	Black	C
33	+12v	Brown	O
32	Common +24v dc		D
31	Stop input (Link from 32 if not used)		E
			R

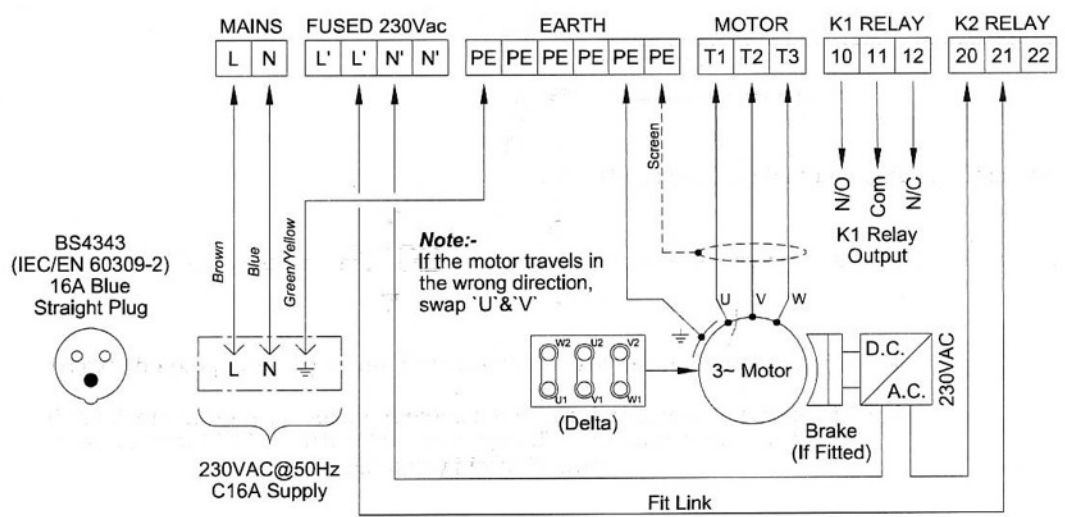

Master

Slave

- 86 Common +24v dc
- 85 Open Dead Man
- 84
- 83 Common +24v dc
- 82 Close Dead Man
- 81

- 76 Common
- 75 Photocell
- 74 Ground -24v dc
- 73 Common +24v dc
- 72 Pedestrian Open (Common from 73 if used)
- 71 Ground -24v dc (Common for opening edge)

- 66 Beacon Sounder (common from 71)
- 65 Open Edge 8k2 Input (common from 71)
- 64
- 63 Ground -24v dc
- 62 Common +24v dc
- 61

- 54 Close Input
- 53 Stop Input (link from 51 if not used)
- 52 Open input
- 51 Common +24v

- 45
- 44 Ground -24v (Common for Close Edge)
- 43 Close Edge Input (Common from 44)
- 42 Common +24v dc
- 41 Stop Input (Link from 42 if not used)

- | | | | |
|----|---------------------------------------|-------|---|
| 36 | Ground | Blue | E |
| 35 | Channel B | White | N |
| 34 | Channel A | Black | C |
| 33 | +12v | Brown | O |
| 32 | Common +24v dc | | D |
| 31 | Stop input (Link from 32 if not used) | | E |
| | | | R |

Master 2 core
From relay 2
20 and 21

- 22 Slave Connect
- 21 To terminals 41
- 20 And 42

- 12 Green Traffic Light +24v dc
- 11 +24v dc Link
- 10 Red Traffic Light +24v dc

Note; Minimum 0.5mm Shielded cable to be used for this connection. Shielding connected to earths

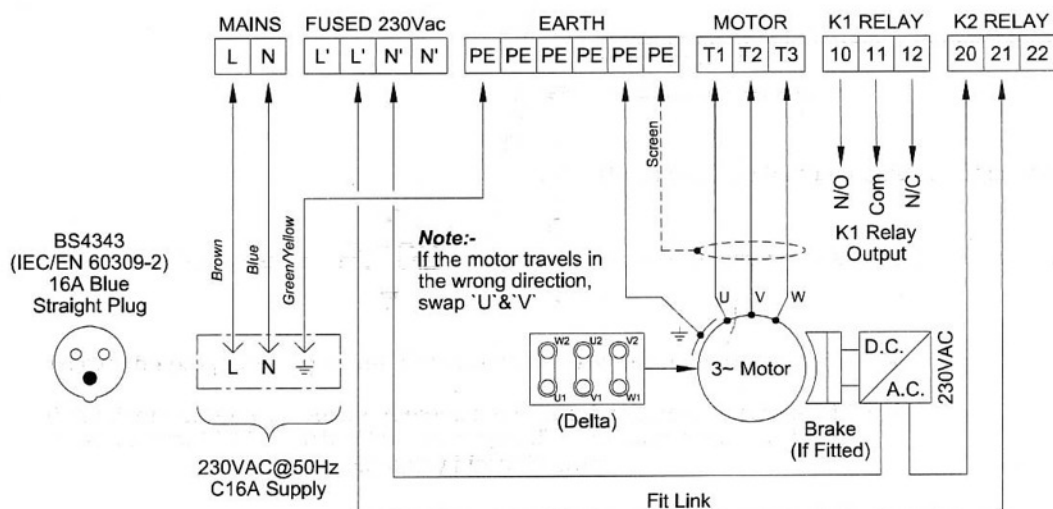
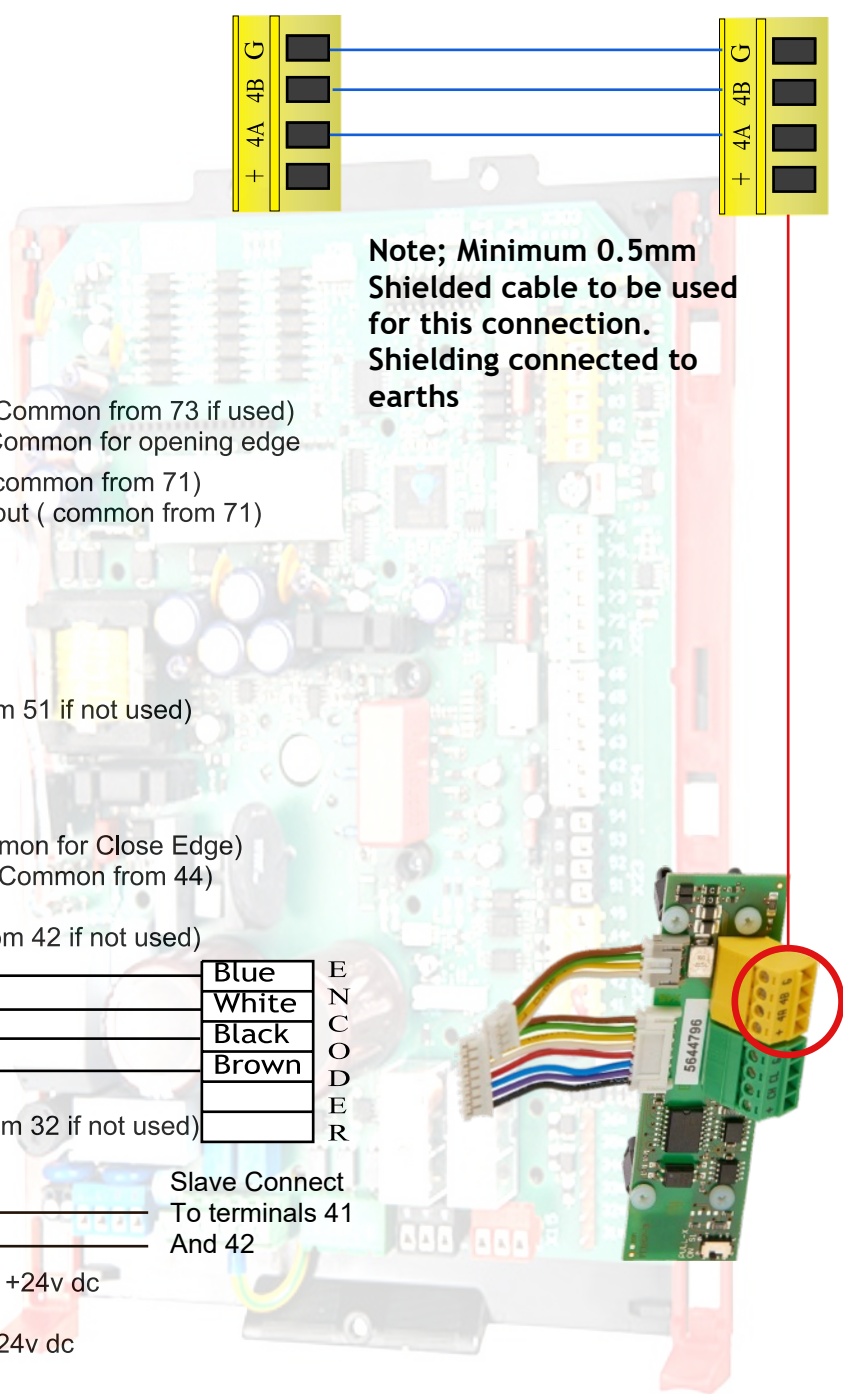

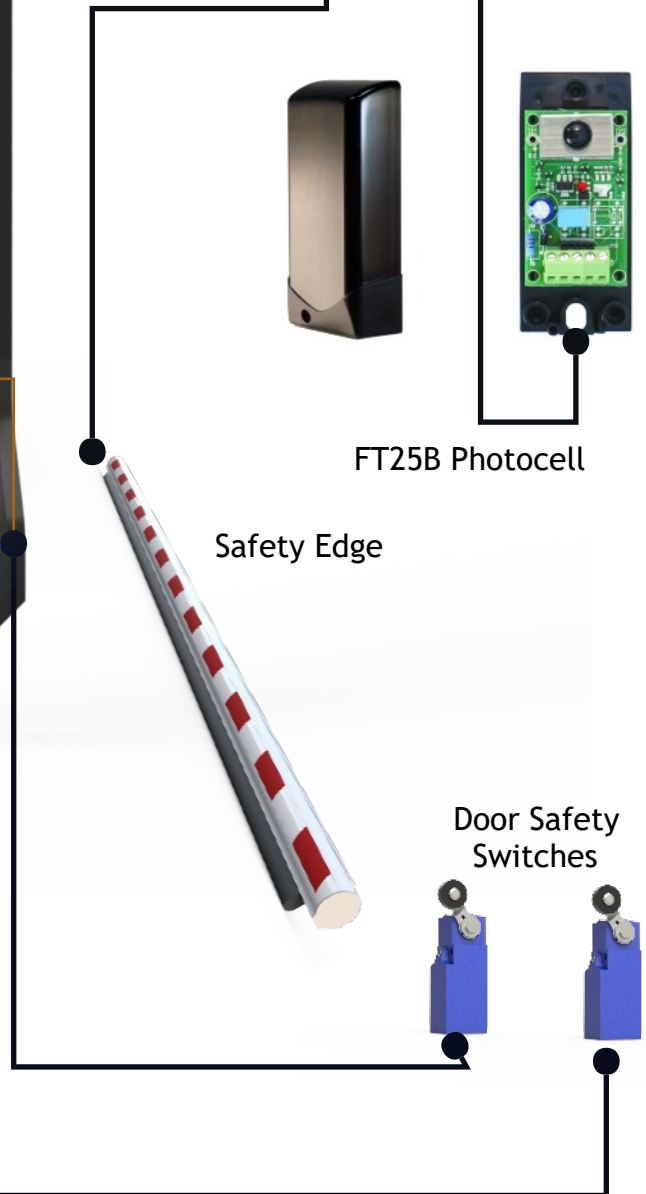
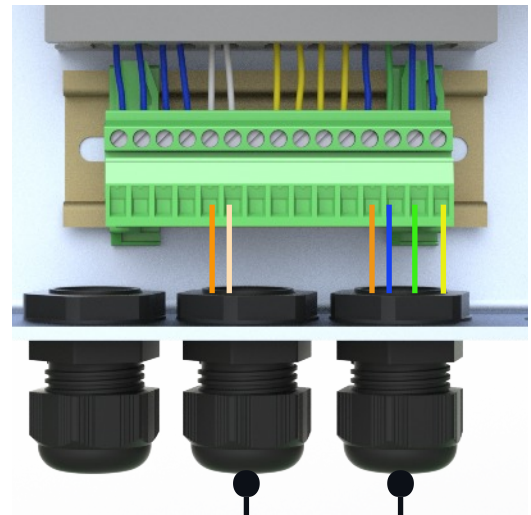
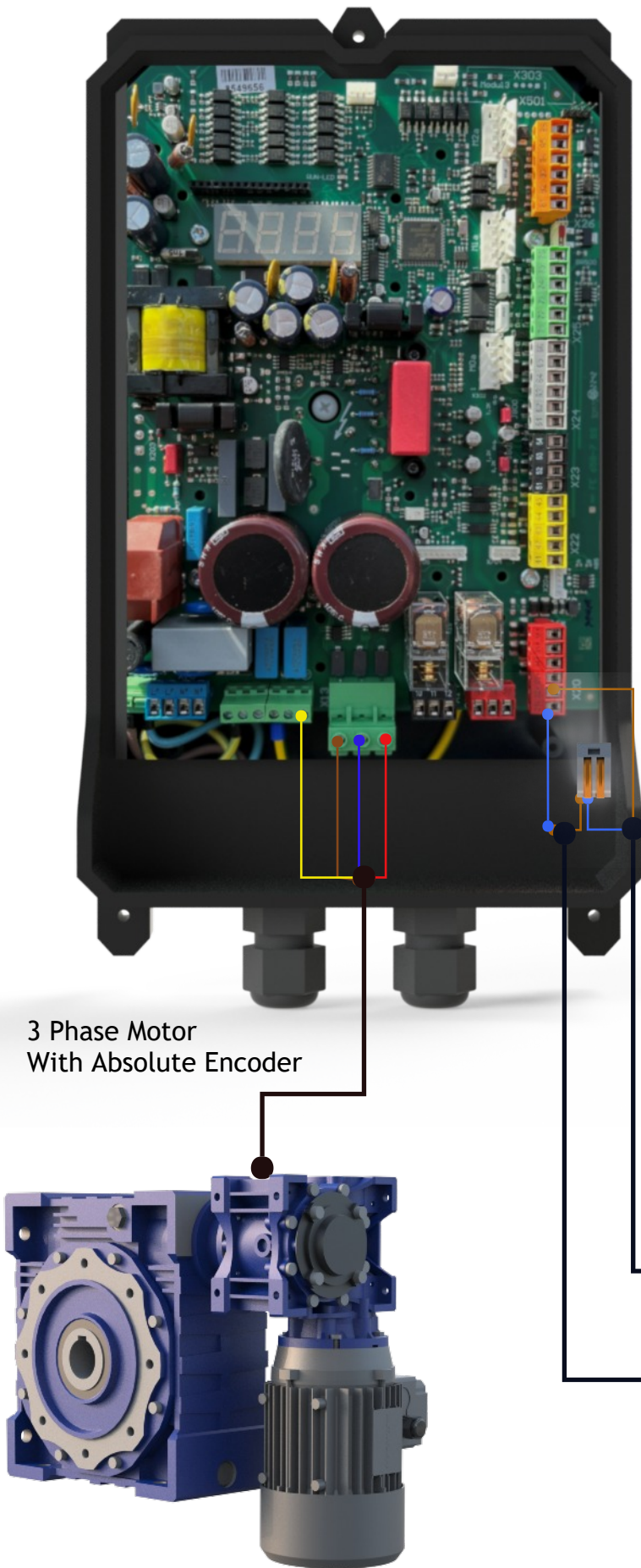



Shown above and below are typical installations of a master / slave setup of our D3850 barriers. The connections between the two boards can be found in the previous page, we would always recommend a minimum of 0.5mm screened cable to connect the boards together with the screening connected to the earths in the board to eliminate the chance of any interference. We would also recommend using separate ducts for mains and data cables to again reduce the risk of any interference on the board data connectivity. On our Master / Slave setup all signals and safety's such as loops, open signals, photocell contacts etc will be all wired in to the master barrier this will then relay the signals through to the slave barrier in real time. Both barriers will however need the mains supply connecting to them independently.

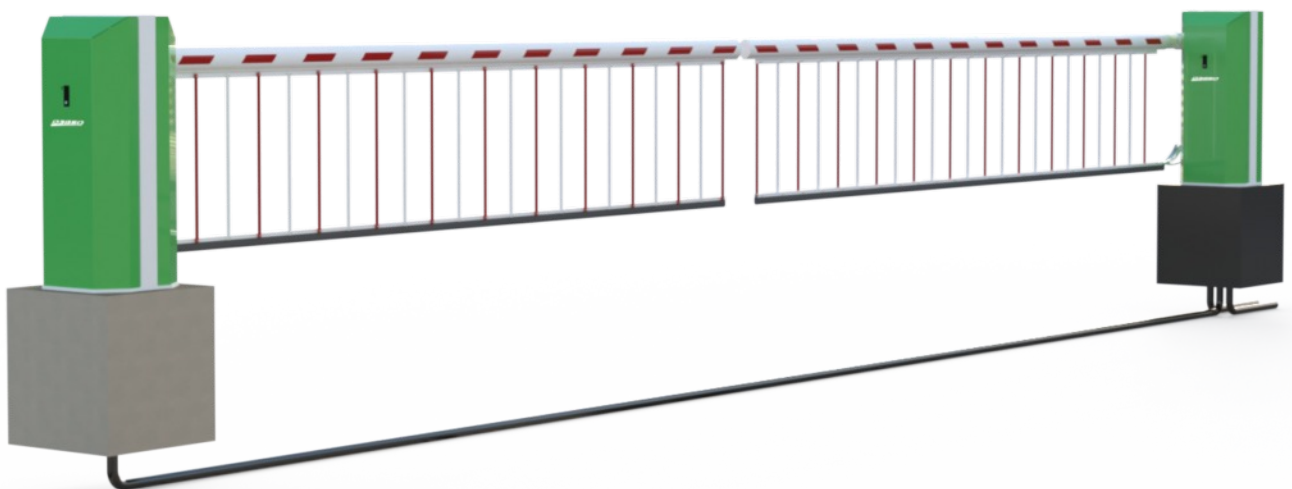

The D3850 barrier will arrive pre set to a point with all safety devices tested. The barrier is set-up and tested in our workshop prior to delivery without the pole being fitted. The encoder therefore may need adjusting to suit your site or pole when fitted. Details on how to enter the menu and adjust your encoder can be found in the following pages. Please note small adjustments shouldn't affect your slow positions dramatically however should you wish to re teach the slow downs etc Details can be found over the next two pages. Should you be happy with the speeds and slow positions Please follow the next two points.



At this point I would suggest allowing the barrier to fully close and make sure you are happy with run speeds and slow down positions.

Should you need to alter any of these settings details can be found on the following page on our walk through guide.

Initial Parameters, to access the initial parameters please press and hold the stop and up arrows to access the initial menu from here the parameters are as follows;

<i>Panel code</i>	<i>Operation</i>	<i>Setting</i>
P010	No passage Timer	In secs, 0 = off
P000	Cycle counter	Operations
P011	Ped close timer	Set in secs
P920	Error log last 8 faults	Codes

Set Up

Step 1,

If you are happy with the barriers positions please test all safeties as normal, I. e safety edges and photocells. If The barrier positions need resetting please follow the following few steps to re calibrate the encoders.

Step 2,

Should we need to reset the positions on the barrier please follow these steps.

You will need to access the parameters menu. This can be done by pressing and holding the stop and up arrows together. See figure 1

Figure 1

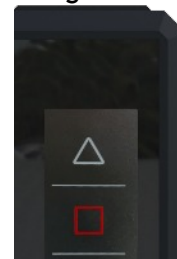

Step 3,

Navigate through the menu to parameter 999 (figure 2) using the up arrows. (Note holding the down arrow and pressing the up will move through parameters in blocks of ten for ease)

Figure 2



Step 4,

Once at P999 press and the stop button this will enter the parameter allowing you to change the value. Please set this to number 3 using the up arrows and confirm by holding the stop again for 2 seconds. Figure 3) to exit the parameter just press the stop key.

Figure 3



Step 5,

Now navigate through the menu to parameter 210 and set this to 5, this will reset the encoder allowing you to re calibrate the gate. Please follow previous steps until you are happy with the positions and safeties.

Note This setup is the same for single barrier and master and slave. The buttons will only work the barrier to which they are installed. To test both barriers on a bi parting set-up, (Master and Slave) please use the open and close inputs on the board.

When you have the Barrier powered and ready to run please follow the next few steps to initially set up your encoder run positions. This will only need setting once.

Figure 4

Step 6;
Once Reset provided there are no faults the board will display the message Cali, this is asking you to calibrate the encoder. Figure 4



Step 7;
When ready press the stop button briefly. The board will now display The EI-EC asking you to sync to lower position. Note the dots between the letters will be flashing.

Figure 5

Step 8;
Simply hold the down arrow to lower the barrier to its desired position, don't worry if you let go early simply press the down to jog the gate to position. Once at your desired lower position press and hold the stop until the dots stop flashing this will record the close position and then revert to the open sync, Figure 5



Step 9;
Please now using the up arrow move the barrier to its desired raise position. Again once happy press and hold the stop button until the dots stop flashing to store the open position.



Step 10;
The barrier is now set and ready to operate, before testing safeties I would advise at this point to give the barrier an open and close operation to ensure the positions are correct and you can see the slow downs and ramps operating correctly.



Step 11,

To change any parameters or settings you will first need to access the menu. This can be done using the stop and up keys depressed together for a few seconds which will enter the parameters list.

Step 12,

When you first enter the parameters list this will be an abbreviated list until you access the full menu. This can be done by navigating to P.999 (Figure 6) then pressing the stop key to access this parameter.

Figure 6



Step 13,

Once into the parameter you will see the digits set to 000. Please using the up arrow navigate to 3 (Figure 7) once this is in place hold the stop key for 2 seconds to confirm your selection. You can then press the stop key once to return out of this parameter.

Figure 7



Step 14,

Now that you have access to the full menu this can be navigated using the up and down arrows, (Note holding the direction you wish to travel in and cycling the opposite arrow will jump through the menu in blocks of 10 parameters) Alter parameters as detailed above. Once finished you can simply hold the stop key to exit the menu and return to normal usage.

<i>Motor Code</i>	<i>Operation</i>	<i>Frequency</i>
P310	Opening Speed	Hz
P320	Opening Slow Speed	Hz
P322	Opening Ramp	Hz per second
P350	Close Speed	Hz
P360	Close Slow Speed	Hz
P362	Closing Ramp	Hz per second
P312	Open Acceleration	Hz per second
P352	Close Acceleration	Hz per second
P222	Close slow position	In Increments Of travel
P232	Open slow position	In increments of travel

To set the timers on the feig board follow the instructions to access the full parameters 999 set to 3, The timers can then be adjusted as follows to suit sites requirements. Please note with timers and parameters setting them to the 0 position will turn the timer off.

Parameter	Description	Timers
P010	No Passage Timer	30
P020	Open Delay Timer	0
P025	Close Delay Timer	0
P712	Traffic Light Delay	0

Customisable parameters, bellow is a list of parameters and functions that are offered with the control board please note the feig controller does not have a built in time clock. These can be supplied on request and programmed to suit site requirements.

Parameter	Description	Values
P000	Cycle Counter	Full Gate Cycle
P005	Maintenance Counter	Counter Set Between Service Periods
P920	Error Log	Last 8 Errors
P925	Software Version	Current Software Version
P985	Language	0 = English
P232	Open Slow Down	In Increments Of Travel
P222	Close Slow Down	In Increments Of Travel
P582	Normally Closed Limits	0 = On 1 = Off
P487	Safety Close	0 = Off 2 = On
P501	2 Step Logic	0204

The loop board can be added to your Feig controller as per the diagram these simply push in for ease and allow easy control for single or dual channel.

L.E.D Indications

- Green fast flash - Detector Tuning
- Green Solid Light - Detector is ready
- Green and Red on - Loop detecting
- Red Solid Light - Loop Fault

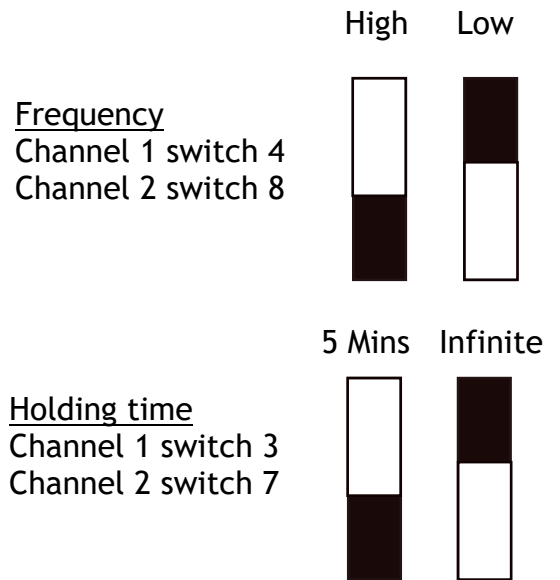
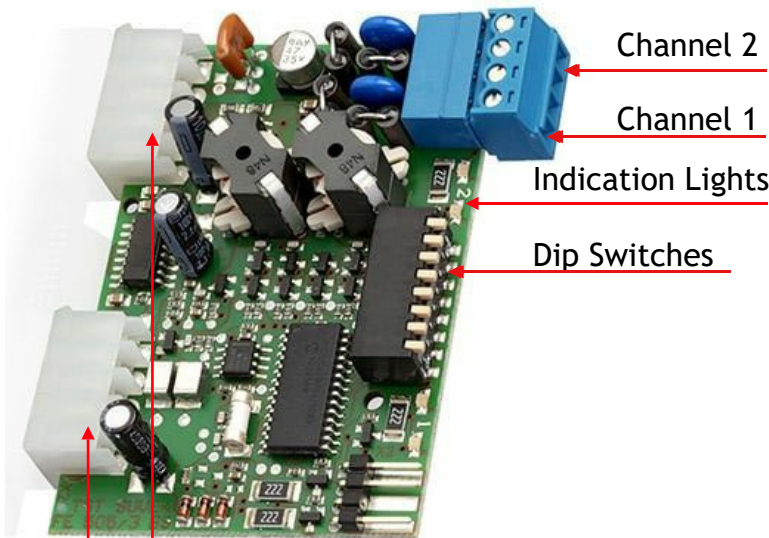

Dip switches 1 and 2 for sensitivity loop 1
Switches 5 and 6 loop 2



The loop card when used must be activated this is done by changing up to three parameters on the feig controller depending on the application and functionality of the loops to be installed.

P.802 - 0302 This activates the loop card.

P.660 Channel 1 -

P.670 Channel 2 -

23 This activates the safety function of the loop card.

22 This activates the free exit (open signal) from the loop card.

20 Turns the parameter off

If master slave or double leaf the 660 and 670 parameter will need changing on both panels.

Step 1;

First make sure the Mains supply is isolated and the barrier has no pole on. Then using the Manual winder, Wind the barrier into the lowered position as shown in Fig 1 Left handed barrier and Fig 2 Right handed barrier

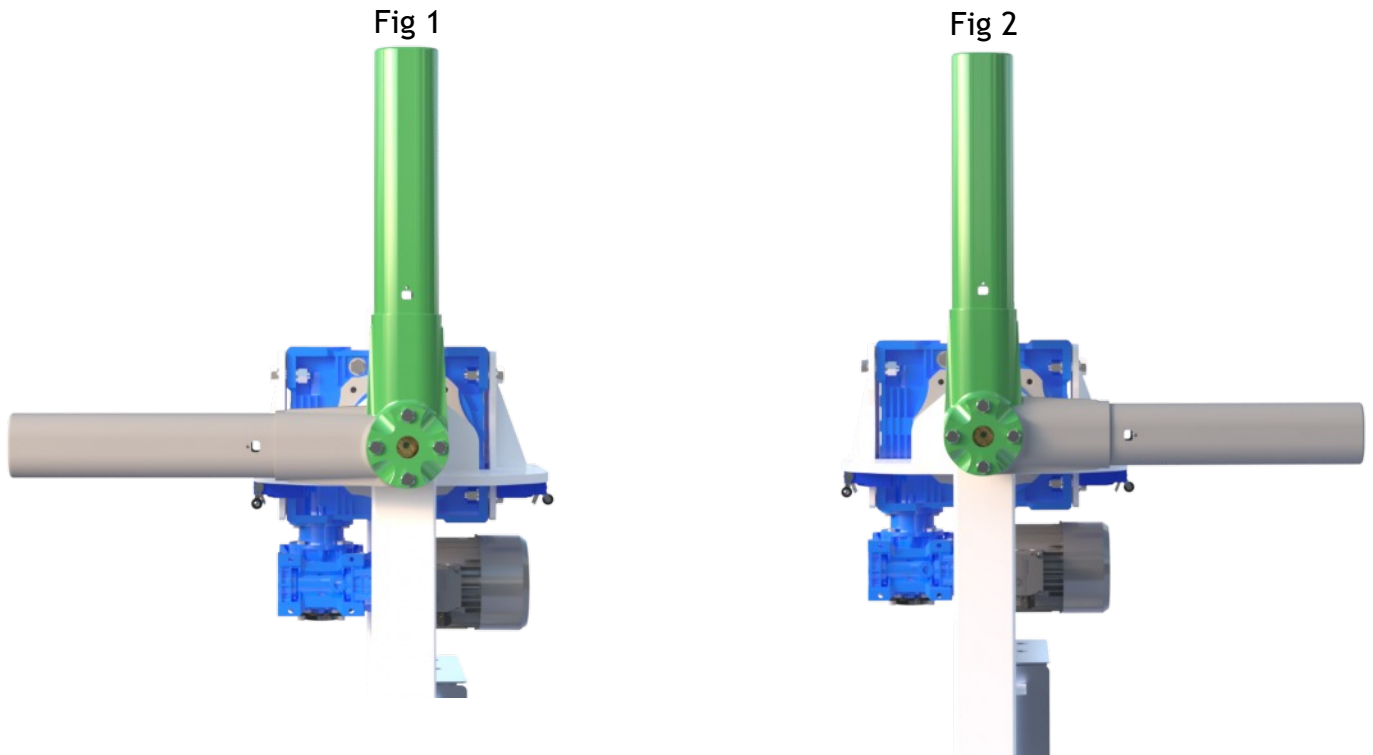

Step 2;

Now undo the m12 bolts holding the pole arm adapter to the shaft. Rotate the pole arm adapter 90 degrees to the raise position and re fix to the shaft.

Step 3;

The motor direction will now need altering as the barrier will now raise and lower opposite to the previous set up. This can be done by swapping any two of the motor phases as shown in Fig 3, The barrier can now be lowered using the manual winder and the pole re-attached. **Please note the barrier will now require re-calibrating following the previous set up process.**

Fig 53

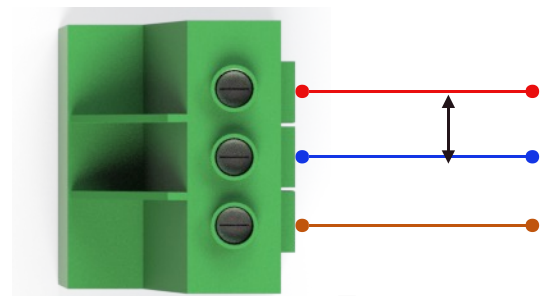

To reverse the motor swap any 2 of the phases

Barrier Troubleshooting Guide

Please use the following instructions to operate the barrier manually, the following is assuming you have powered down the unit.

To Manually release the barrier please remove the cover using key supplied, then take the release Handle (which will be handed over with the keys) and insert into the motor and rotate. Direction depends on Barrier handing. Once the barrier is wound to the desired position replace the release key and replace the cover and re-lock.

Note the cover has a safety switch on it that will not allow the barrier to operate if the cover is not fully closed.

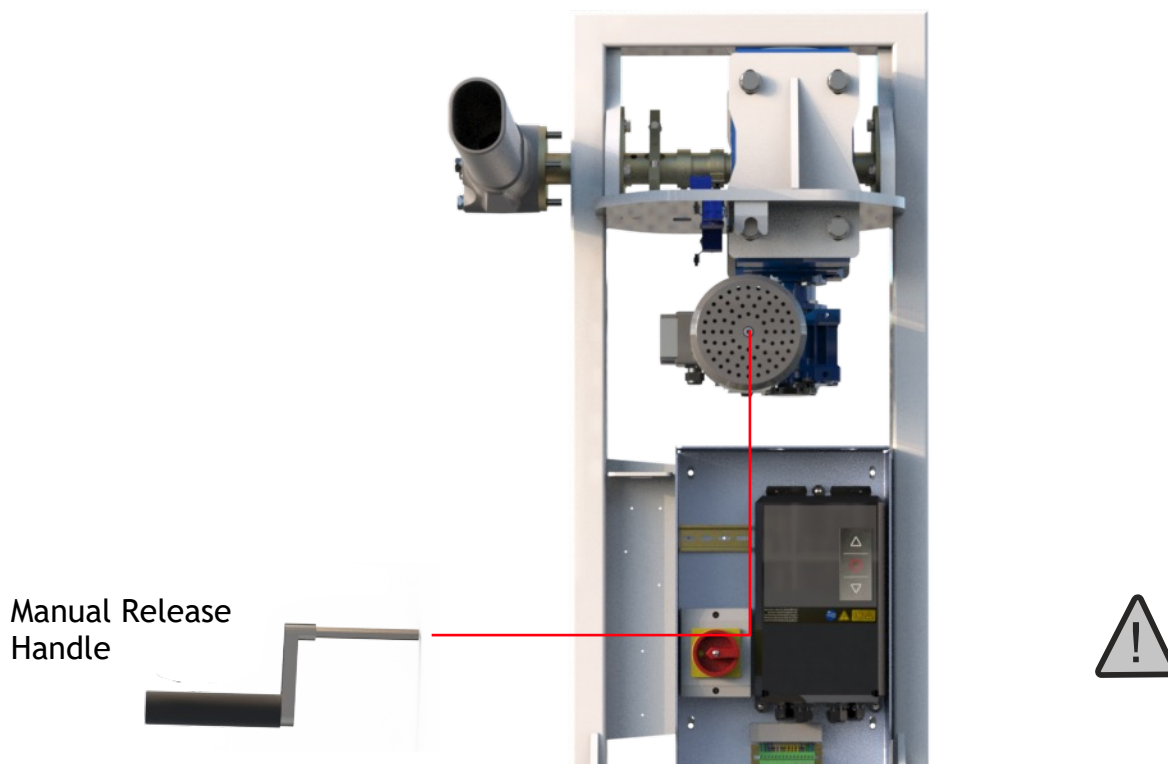

Barrier Troubleshooting Guide

Please Note the power must be isolated from the barrier before any manual operation is performed!

MECHANICAL ERRORS	CAUSE	CORRECTION
Barrier arm keeps going up and down	Limit switch fault	check and reset limit switches
Barrier creaking when moving	Check bearings	Oil or grease bearings
Barrier motor not running	Loss of voltage	Check motor supply test 3 phases
Barrier not raising or lowering	Positioning / Motor issue	Call service team to diagnose fault
Barrier not raising or raising half way	Gearbox	Gears stripped due to overloading replace
Barrier raises slowly and lowers too quickly	Slow positions not defined correctly	Contact installer to re-commission
Barrier not running at all	Door has been left open or switch not pushed in	Close the door and issues a signal to open or close
Barrier raised will not lower	Key switch is left in open position	Turn key switch to auto
	Loop fault or loop detecting	Check if green light is on detector if so remove object that it is detecting or
ELECTRICAL ERRORS	CAUSE	CORRECTION
Blank screen on lcd but power to other devices in the control panel	On-board fuse blown or short	Unplug accessories / Replace fuse
	Lcd has developed an electrical fault or had a power spike	Change control panel
Barrier does not run (stays open)	Check Controller for error code	Locate issue as appropriate to code
	Loop detector is faulting or sensing presence	Clear obstacle / reset the detector
	Check Photocells power	24vdc or 3.6v Batteries to replace
	Barrier staying up in raise position	Open signal latched from access controls
	Photo cells dirty (if fitted)	Clean photo cells make sure they are debris free
	Stop circuit broken	Check door switches/access controls
Mains on but no power	Isolator fuse	Check and meter fuse in isolator
Barrier not going up	Access control may be faulty	Raise and lower barrier from buttons on controller
	Door switches poor contact	Remove and re-fit doors

Code	Fault	Remedy
HD	Deadman Operation	Closing Fault Codes
E360	Closing Edge	Check for 8k2 on edge circuit
E101	Open Signal	Check open signal connections
E102	Stop Circuit	Check emergency stop and links in board
E103	Close Signal	Check close signal connections
E105	Photocell	Check cells linked out, loop link
E501	Loop 1 Error	Check Loop for Continuity
E502	Loop 2 Error	Check Loop For Continuity

<i>Fault Codes</i>	<i>Operation</i>
F700	Position Fault
F030	Motor stalled
F020	Run Time exceeded
F211	Stop circuit broken
F212	Stop circuit broken
F361	Closing edge over activation
F360	Close edge fault
F363	Close edge open circuit

We certify that the system covered by this certificate has been commissioned satisfactorily.			
Site Name		Completion	
Site Reference		Engineers Installing	
Installation Commenced	/ /	Commissioning	
Equipment Fitted			
Handover Date			

Part 2. Existing Installation Items not covered under warranty/ This certificate:

Part 3. Certificate Signing off

Installers Name		Signature	
On Behalf of		Date of Signing	
Address		Position	
Client Name		Signature	
On Behalf of		Date of Signing	
Site Address		Position	



As stated at the beginning of this manual we recommend a bi-annual service, but at a bare minimum, it is imperative that you get a service done once every 12 months. This is not a sales tactic in disguise, there is a very serious health and safety issue/risk associated with not complying to this. Also in order for your barrier to keep complying with the appropriate legislation. All machinery products must conform to BS EN 12453:2017+A1:2021 for the supply of powered machinery safety regulations.

Before carrying out any maintenance to the installation, disconnect the mains power supply.

A Maintenance Contract should be sought from a specialist company after a maximum of 5000 manoeuvres or 1 year from the install date.

Occasionally clean the photocell optical components and make sure they are free from dirt, water, rain, soil etc.. ? Batteries in photo cells may need to be changed every on every service or sooner dependant on use. Barriers will not work properly without photo cell function..

If the power supply cable is damaged, it must be replaced by the manufacturer or its technical assistance service, or else by a suitably qualified person, in order to prevent any risk. This must conform to BS 7671:2018+A3:2024

When any operational malfunction is found, and not resolved, disconnect the mains power supply and request the assistance of a qualified technician (installer). When automation is out of order, activate the manual release to allow the opening and closing operations to be carried out manually.

Gearbox drive unit is “sealed” for life and requires no further lubrication.

Maintenance Check List;



- Door Locks Checked
- Bearings Greased
- Rod Eye Bearings Checked
- Safety Devices Checked
- Door Switches Checked
- Encoder operation Checked

-
-
-
-
-
-



Your Barrier will conform to BS EN 12453:2017+A1:2021 the standard for powered machinery and any additional amendments to this critical safety standard. We manufacture barriers and equip them with safety and other options, only to the extent specified by our customers. Therefore, the barriers, as delivered, may not represent a complete machine as defined by the regulations. As such, the addition of any after market safety devices by the client must conform to this standard as well as BS EN 12978:2003+A1:2009 the standard for sensitive safety devices. The three main points of covered in this standard are the installation, design and elimination of hazards and electrical control system integrity also the Implementation of devices designed for safe contact (force limitation) such as resistive safety edges. The standard also covers Non Contact (presence detection that prevents hazardous contact) such as and not limited to, photocells, light curtains, radar sensors and inductive loops.

It is imperative that the installer carries out an onsite risk assessment prior to fitting or maintaining barriers, and a residual risk assessment once the installation is complete. These will highlight any remaining safety issues, and allow the installer to fit additional equipment or draft suitable protocols for operation of the equipment. Therefore the product must be installed and maintained by a competent, qualified and well trained company or individual.

As standards are ever improving the safety devices and systems in use may need to be upgraded from time to time. The standards will always refer to 'state of the art' safety devices being used in conjunction with the product. However the emphasis is always preferred on non contact devices with the back up of sensitive (force detecting products also).

To add additional safety products and accessories to an existing product the relevant paperwork and Declaration of incorporation (or Certificate of Compliance as appropriate) must be updated and kept for the relevant standards to be adhered to.

All Electrical supplies to Barriers and machine products must be installed to the correct Standard i.e. the current edition of BS 7671:2018+A3:2024 and any alterations to this supply must be recorded and adhere to this standard. These can be recorded in the Electrical installation Certificate or the Periodic Inspection report.

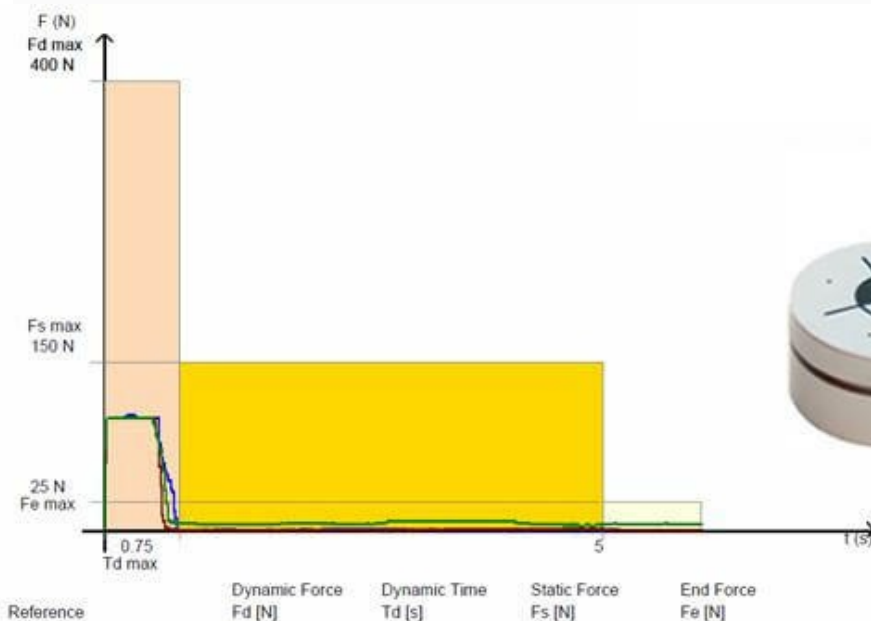

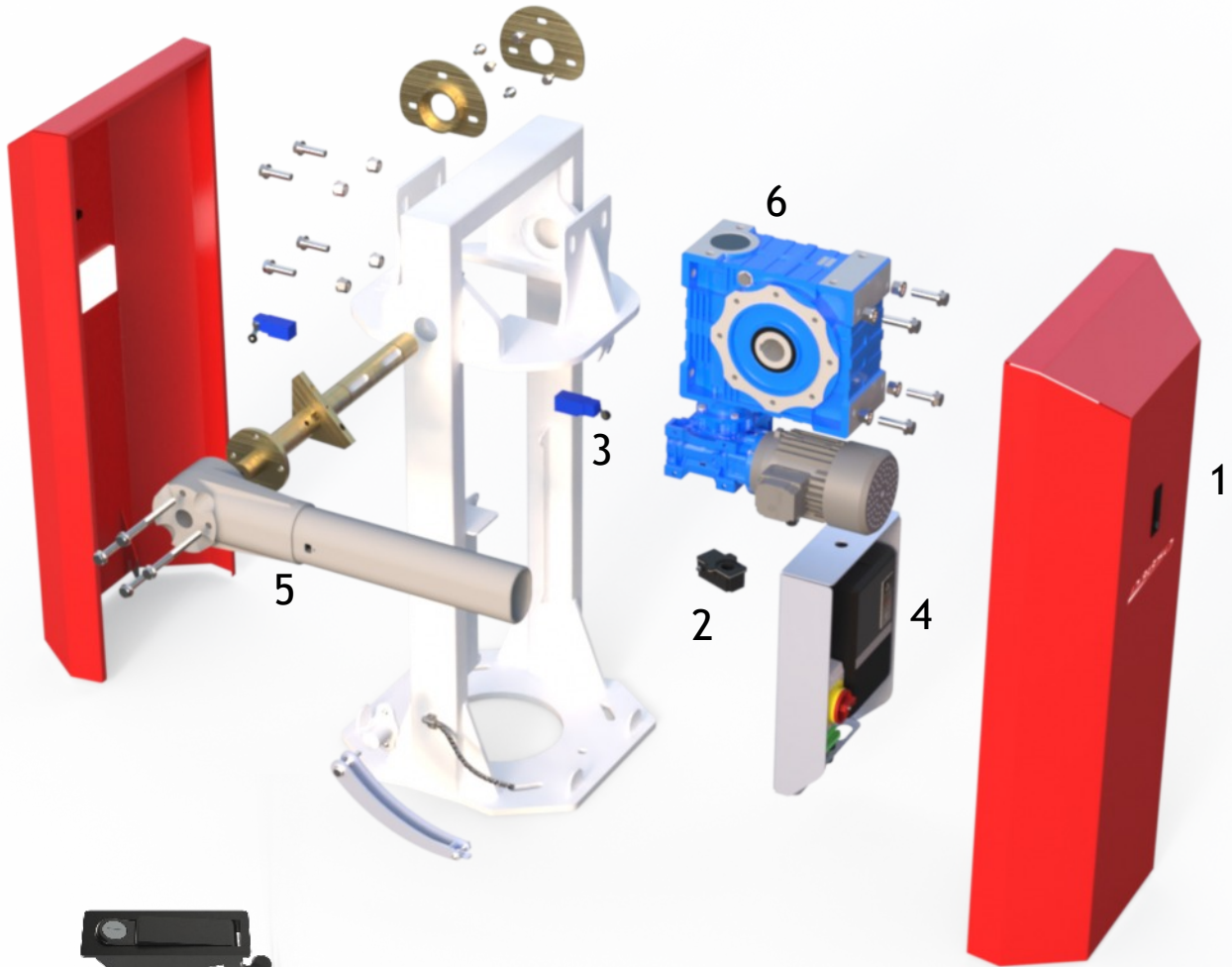

Door Lock



Encoder



Door Switches



Feig Control Panel



Pole Arm Adapter

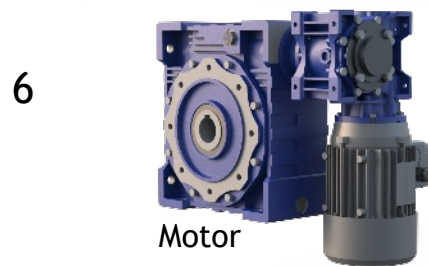

Motor



Manual Winder

Declaration of Conformity

In accordance with BS EN ISO/IEC 17050-1:2010

We: Ultimation Direct Ltd

Of: Trent Lane, Maltkiln lane, Newark, Notts NG24 1HN In

accordance with the following directives:-

Supply of Machinery (Safety) Regulations 2008

Electromagnetic Compatibility Regulations 2016

The Radio Equipment Regulations 2017

Hereby declare that:

Equipment: Automated Traffic Barrier

Model no: D3250E

Are in conformity with the applicable requirements of the following documents:

Supply of Machinery (Safety) Regulations 2008.

BS EN 12453:2017+A1:2021 Industrial, commercial and garage doors and gates—Safety in use of power operated doors— Requirements.

BS EN 12604:2017 Industrial, commercial and garage doors and gates—Mechanical aspects—Requirements and test methods.

BS EN 13241:2003+A2:2016 Industrial, commercial and garage doors and gates - Product standard. Products without fire resistance or smoke control characteristics.

BS-EN12978:2003 Industrial, commercial and garage doors and gates. Safety devices for power operated doors and gates. Requirements and test methods.

BS EN 13856-2:2013 Safety of machinery. Pressure sensitive protective devices. General principles for the design and testing of pressure sensitive edges and pressure sensitive bars.

I hereby declare that the equipment named above has been designed to comply with the relevant sections of the above referenced specifications. The unit complies with all applicable Essential Requirements of the Regulations.

Signed:

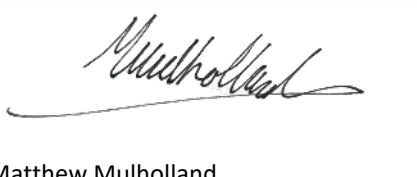

Name: Matthew Mulholland

Position: Technical Director

Place: Newark

Date: March 2026

Specification

Maximum Boom Length: 9.0 metres
Power Requirement: 230v, Single Phase, 50Hz, 16 Amps
Drive Motor: 3 Phase motor & wormed gearbox
Opening/Closing time: 1.5 - 7.0 seconds
Duty Cycle: 100% continuous duty rating
Operation Time: 8 Seconds per metre (Variable)
Finish: Polyester Powder Coated
Dimensions: 508mm x 505mm x 1215mm

Access Controls: Push-button, Proximity cards, card readers, tokens, voice/video intercoms, keypads and remote fobs.

Motor/Gearbox

Electric Motor:

400v 50hz 3 phase
 6 pole
 IP55
 8mm End Cap
 B14 C face mounted
 Frame size 80
 Output power: 0.55kW
 Current @ 400v: 1.70A
 Rated speed: 885rpm
 Full-load power factor(cos): 0.72
 Full-load efficiency: 65%
 Locked rotor current is/in: 4.7
 Locked rotor torque Ms/Mn: 2.0
 Break down torque Ms/Mn: 2.1
 Net weight 9.2kg
 Driving end bearings: 62042RS/C3

Geared Motor Spec:

Type: Worm & Wheel
 Overall speed: 2 rpm
 Max rated torque: 1050nm
 Actual torque: 1000nm
 Gearbox efficiency: 40%
 Output size: 42mm
 Mounting position: V5
 Angular Backlash: 15' +/- 5' / 0.00436
 +/- 0.00145 (W110)
 Lubricated with: Shell Omala 1.7 litres (W110)

Accessories

Optional extras:

- ✍ Folding bottom skirt up to 8.0m
- ✍ Hi-Bar skirt up to 7.0m
- ✍ Pogo tip support
- ✍ Boom lights
- ✍ Magnetic lock
- ✍ Lorry height stop/no entry signs
- ✍ Warning sounder/flashing Beacon
- ✍ Sensing safety edges

Made in the UK

