

*O&M Manual*  
*Revision 2.0*



***D4150*** Full Height Turnstile

120 Degree Rotor  
100 % Duty cycle

1. Inductions and warnings	Page 03
2. Delivery, Movement and transport	Page 04
3. General Layout	Page 05
4. Pre Install Guide	Page 06
5. Bits Boxes	Page 07
6. Installation Guide	Page 08 - 10
7. Double Install	Page 11 - 12
8. Integrated Pedestrian Gate	Page 13 - 14
9. Turnstile Layout	Page 15
10. Terminal List	Page 16
11. Parameters, Down Lights, Date and Time	Page 17
12. Servicing and Maintenance	Page 18
13. Trouble Shooting	Page 19
14. Fault Texts	Page 20
15. Mechanical Issues	Page 21
14. Commissioning Certificate	Page 22
15. Service Log	Page 23
16. Technical Data	Page 24

This equipment is part of a large range of traffic flow products. They are designed to be easy to install, as all settings and internal wiring have been completed in our factory. Any of the instructions in this manual should only be carried out by a qualified service engineer or a competent person.

The turnstiles are ready to bolt down, connect to a single phase power supply and have any access control wired into them (Please note that advice should be sought on wiring instructions). The steps must be completed before the power is turned on to prevent accidents.

The following information is a guide only, and whilst we have made every effort to be accurate and correct there may be errors which we cannot be held responsible for.

With a correct installation you can expect to enjoy many years of reliable service from this product, we do however recommend that the product has a bi-annual service carried out by a qualified engineer. Please contact our service department to obtain a quote. As we manufacture the products we are best suited to care for your equipment.

Thank you for your custom and welcome to the exciting world of Total Traffic Flow Solutions.

## Important Safety Notice



Automatic turnstiles are designed to Control the flow of human traffic only. It can be dangerous to allow the passage of any other self-powered animal or device to utilise this method of access without appropriate warnings and or signage. It may be necessary for the end user of this product to provide an alternative, safe method of access to cater for the previously mentioned categories. The end user should fit all necessary signage and warning notices to either side of the turnstile, which should be visible and clear from all directions of approach. The product that was shipped to you was designed with a control program to protect all categories from harm or affect this however is only a precaution. It should not be modified or tampered with by any unauthorised person not sanctioned by the manufacturer.

Please sign and date below to say that you have read and understood this notice before ANY installation work:

/
/20

The "Warnings" leaflet and "Instruction booklet" supplied with this product should be read carefully as they provide important information about safety, installation, use and maintenance.

Scrap packing materials (plastic, cardboard, polystyrene etc) according to the provisions set out by current standards. Keep nylon or polystyrene bags out of children's reach.

Keep the instructions together with the technical brochure for future reference.

This product was exclusively designed and manufactured for the use specified in the present documentation. Any other use not specified in this documentation could damage the product and be dangerous.

The Company declines all responsibility for any consequences resulting from improper use of the product, or use which is different from that expected and specified in the present documentation.

Do not install the product in explosive atmosphere.

The construction components of this product must comply with the Applicable regulations and subsequent amendments. As for all non-EEC countries, the abovementioned standards as well as the current national standards should be respected in order to achieve a good safety level.

## Information on using this manual



- ☐ Read all information thoroughly
- ☐ Pay attention to all safety advice
- ☐ Be aware of the symbols (shown above right and above left) as they have different meanings. One is an information symbol, the other a warning.
- ☐ There are many artists impressions of the product in this manual you should refer to the images as a guide only. Professional CAD drawings should be used as a reference drawing and nothing else. As before every effort has been made to be 100% accurate in this manual but we cannot make any guarantees.
- ☐ As we constantly innovate our products we may change the quoted spec and any other details that have been documented in this manual so you should always refer to the supplier to see if the manual that was shipped with your product is the latest edition.
- ☐ As with all electrical installations you should use a qualified electrician and obey all of the latest laws and regulations.
- ☐ Be sure to fill out and complete ALL paperwork where instructed as this manual is the equipments log book and maintenance manual.

The Company declines all responsibility for any consequences resulting from failure to observe Good Technical Practice when constructing closing structures (door, gates etc.), as well as from any deformation which might occur during use.

The installation must comply with the provisions set out by the applicable regulations and subsequent amendments.

Disconnect the electrical power supply before carrying out any work on the installation. Also disconnect any buffer batteries, if fitted.

Fit an omnipolar or magnetothermal switch on the mains power supply, having a contact opening distance equal to or greater than 3mm.

Check that a differential switch with a 0.03A threshold is fitted just before the power supply mains.

Check that earthing is carried out correctly: connect all metal parts for closure (doors, gates etc.) and all system components provided with an earth terminal.

Fit all the safety devices (photocells, electric edges etc.) which are needed to protect the area from any danger caused by squashing, conveying and shearing, according to and in compliance with the applicable directives and technical standards.

This article describes how your equipment will be delivered to you, specifications on the transportation used and advice including health & safety on movement of the equipment.

The manufacturer will use a qualified transport company to deliver the product conforming to the necessary regulations as detailed below:

- All drivers are qualified
- All drivers are tested once yearly
- All drivers carry risk assessments and method statements (available on request)
- They are controlled under law to conform as there are no trade regulation standards to comply with

Health and safety Considerations:

Moving Goods Safely (MGS) is a national project involving both the Health and Safety Executive (HSE) and Local Authorities (LA) working in partnership. The project aims to reduce injuries and ill-health arising from the movement of goods from supplier through haulier to the recipient and end user including any home deliveries. The project will focus upon the delivery and collection of goods and the hazards this generates. It covers the main areas that cause the majority of injuries and ill-health to workers, including:

- Workplace transport;
- Slips & trips, and;
- Musculoskeletal disorders (MSD).

The movement of goods presents us, as health and safety regulators, with the challenge of dealing with a huge variety of issues. The commercial organisations involved within the movement of goods are diverse including haulier, third party logistics providers, pallet networks, retailers etc, with some very large companies, thousands of small businesses and the self-employed. The movement of goods is more than just trucks on the road with a large proportion of accidents happening at the delivery/collection sites that are often not directly under the control of the company making the delivery or collection. Communication and cooperation problems can arise due to the many organizations involved in the movement of the goods, and this can also lead to difficulties in effectively managing health and safety.

(Source H&S Executive UK 2008)

The Turnstile should ALWAYS! be moved with care and attention. The products are very heavy individually as well as a whole. You should not attempt to move this or any other products by unapproved handling methods.



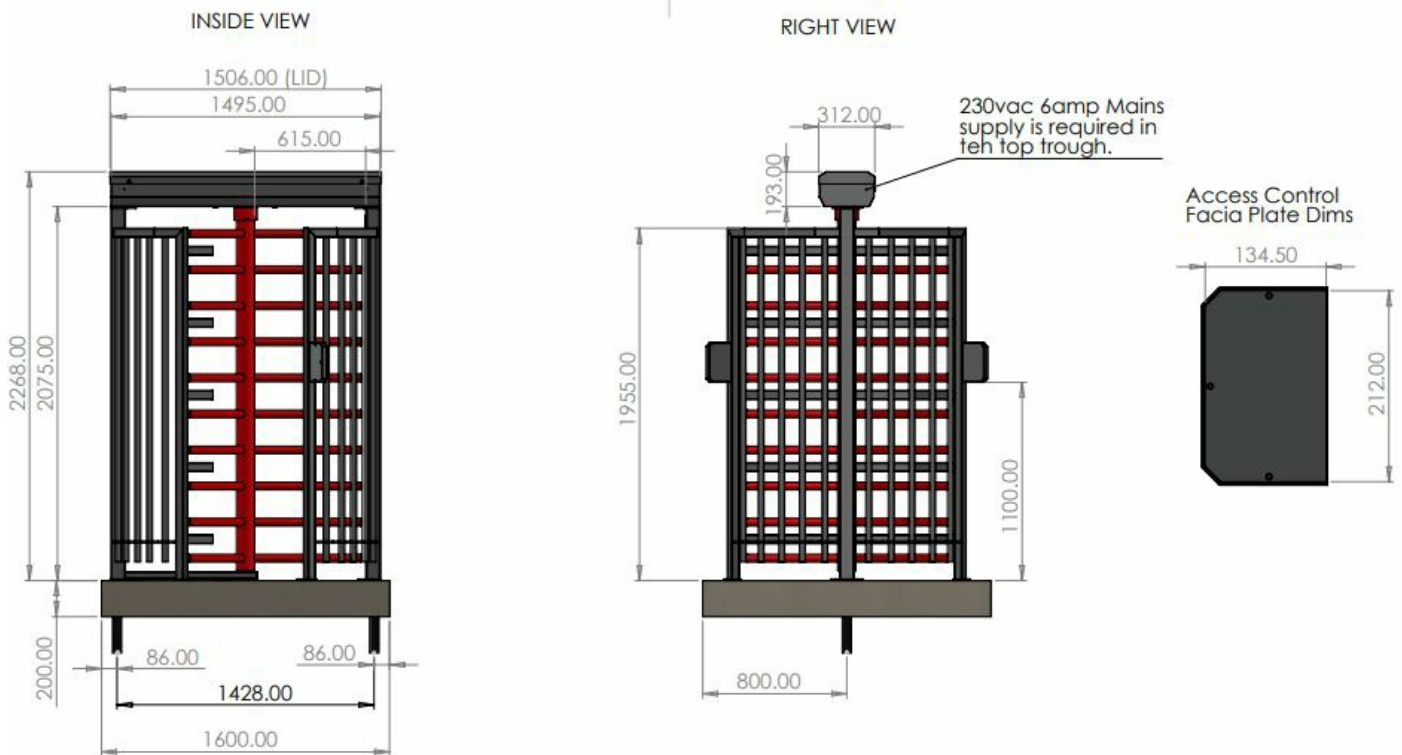

**General Description,**

The D4150 Turnstiles are designed to provide the perfect solution for security and pedestrian access in Industrial locations where Reliability and Security is paramount. Commonly chosen for applications such as multi-storey car parks, prison entrances and corporate entrance and exits, they provide an aesthetically pleasing, high security entrance control solution. They are fitted with our reliable heavy duty Head mechanism which is almost silent in operation and are fitted and within the turnstile trough. They have an Impeccable service record with maximum longevity in the most demanding Environments. Turnstiles are engineered to allow bolt down fixing to suitable level concrete pads, and are compatible with all current access controls. In addition they come with a wide range of access options from single to double turnstiles, full height to three quarter height and with the addition of an integrated or stand alone pedestrian gate if required. These can be semi or fully automated depending on site requirements.





## Foundations

All foundations should be installed as per drawing supplied as base size's will vary depending on the size of the gates. (Contact your supplier if you have not been issued one.) All foundations should be installed 10 x days prior to the gates being installed.

If details of the base have not been specified, we recommend a concrete mix to BS EN 206:2013+A2:2021 "Concrete specification, Performance, Production and Conformity" to type C35, which is equally suitable for external and internal environments.

The foundation must be positioned accurately and installed to the correct levels to ensure successful installation.



Careful consideration should be made when deciding the location of the gate to avoid overhead obstructions such as power cables, telephone wires building canopies, trees and other types of likely obstructions and hazards, which will not

---

## Ducting

Ducting carrying cables for power and control should enter the gate support frame from underground. Two ducts are normally required, one for the power supply, the other for the control. Where the power supply and control cables are to come from a common place; a single duct can be used.

These ducts must be sited accurately in the base as shown on the contract drawing. The use of cable access pits is recommended where there may be a number of ducts used entering the gate or long cable runs are necessary. We also recommend the ducts used be of 50mm diameter PVC. Alternative types and sizes may be acceptable, subject to discussions with your equipment supplier.

Slow bends should always be used wherever possible, and the inclusion of draw ropes throughout the ducting system, will ensure that the cables are easily installed.

**Single Turnstile Bits Box;**

1. Manual Operation Keys
2. 9 x m12 x 125mm Through Bolts
3. 9 x m12 Caps
4. O & M Manual
5. Trough access Keys

**Double Turnstiles Bits Box;**

1. 14 x m12 x 125mm Through Bolts
2. 14 x m12 Caps
3. 2 x Manual Operation Keys
4. O & M Manual
5. Trough access Keys

**Turnstile with integrated pedestrian gate;**

1. Manual Operation Keys
2. 13 x m12 x 125mm Through Bolts
3. 13 x m12 Caps
4. O & M Manual (D4150)
5. O & M Manual (Pedestrian Gate, Type depending)
6. Trough access Keys
7. Specific Bits for ped (Manual / Automated) Please Refer to Ped O & M



### Step 1, Lifting the Turnstile into place

The turnstiles come fully assembled unless you have specified them to come disassembled. If your Turnstile is disassembled follow step 2. If your Turnstile is assembled go straight to step 8.

Note, Please check for Physical damage before you sign for the delivery.

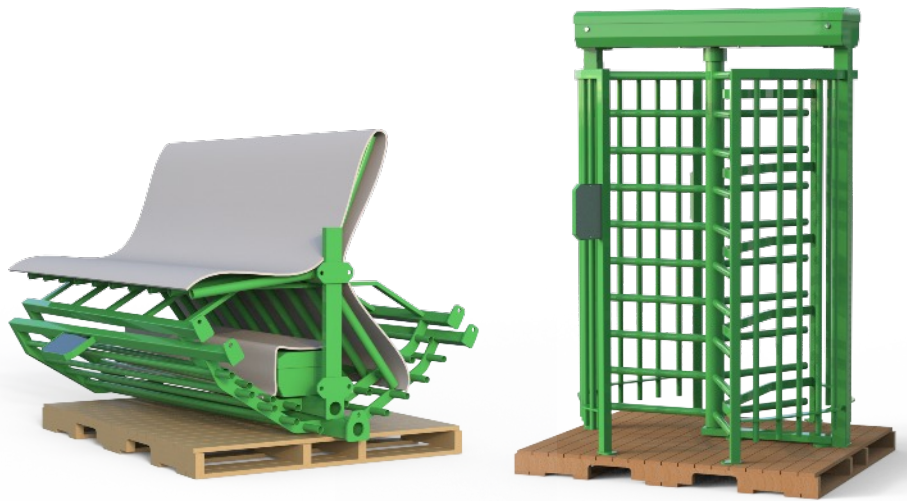

### Step 2, Assembling the Turnstile

Place the two Turnstile radius sides on to the plinth, It is recommended to bolt the first one down to prevent it falling over, then measure the second one as shown in Fig 2 ensuring it is stabilised and cannot fall. Once you have the dimension correct, bolt down the second radius. ( See the generic drawing for the correct dimension )



### Step 3, Assembling the Turnstile - Fitting Trough

Now you are ready to fit the top over head trough, Using the correct lifting equipment place the trough on top of the two radius sides as shown in fig 3, then using the provided M10 x 40 fixings bolt the trough to the sides.

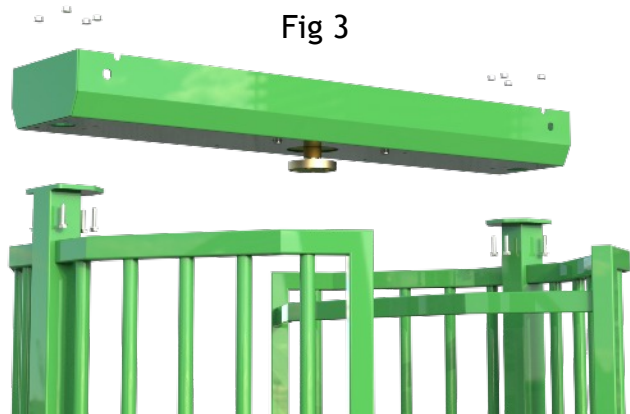

**Step 4, Assembling the Turnstile -  
- Fitting The Rotor**

Now you are ready to lift the rotor in to place, this requires two People to lift, You must first loosen and remove the 4 x M10 fixings that hold the headmech in place and lift the headmech up to allow the room for the rotor. See Fig 4

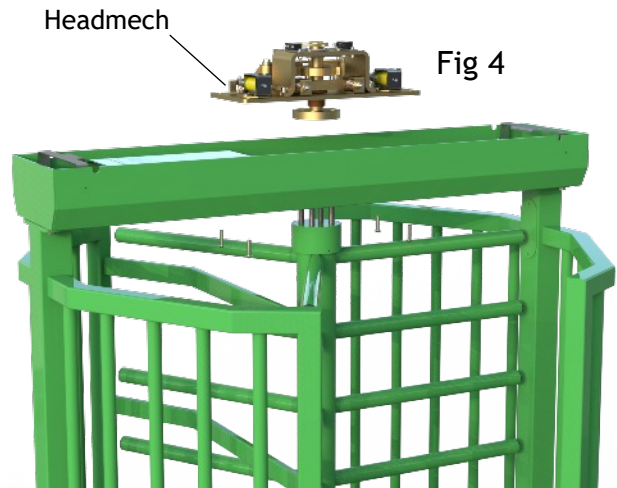

**Step 5, Assembling the Turnstile -  
- Fitting The Rotor**

Now lift the rotor into place, locate the bottom rotor bearing onto the bottom pin and then hold the rotor upright. Shown in Fig 5

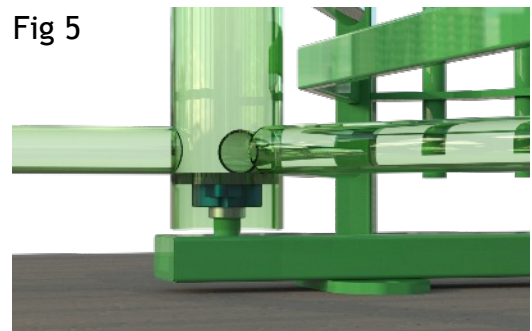

**Step 6, Assembling the Turnstile -  
- Fitting The Rotor**

Now Lower the Headmech down back into the trough, You must Locate the 4 x Holes on the bottom headmech disc with the 4 x studs on the Rotor, it is crucial that you get this alignment correct, Fig 6 shows the correct alignment.

Align the rotor so that the 4 x studs that are parallel with the

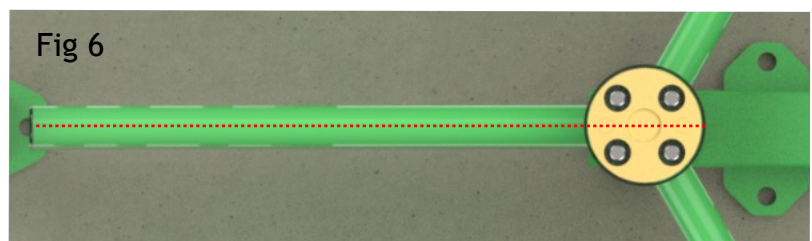
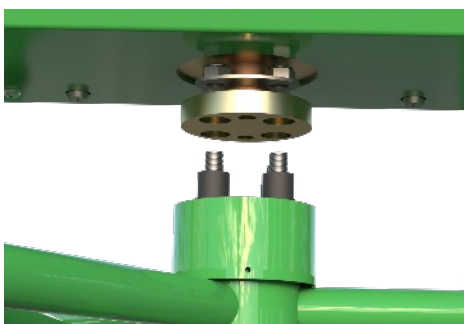
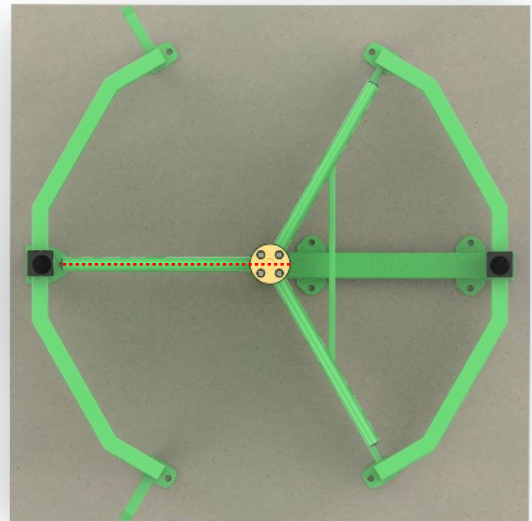

**Step 7, Assembling the Turnstile - Fitting The Rotor**

Now you have the rotor located and the headmech lowered you need to install the 2 x kidney washers and the 4 x M16 lock nuts as shown in Fig 8. Tighten the M16 nuts using a 24mm spanner.

Now lift the collar cover and tighten the M6 grub Screws as shown in Fig 9

At this point now it is worth testing the turnstile mechanically in free wheel to ensure the rotor spins freely and everything is correctly aligned.

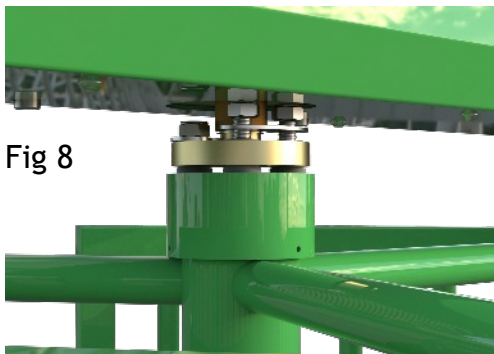

Fig 8

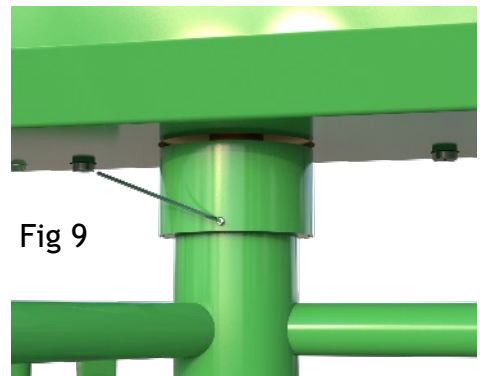

Fig 9

**Step 8, Bolting down the fully assembled Turnstile,  
If your turnstile is delivered pre-built this can be lowered onto the ducting using a crane or suitable fork lift.**

You are now ready to bolt down the Turnstile, Using an SDS drill with a 12mm SDS drill bit drill the Turnstile down to the foundation. It is recommended to bolt one side down first and then check the dimension between the posts as shown is Fig 10, Then check the level and when happy both are correct proceed to bolt down the rest of the Turnstile.

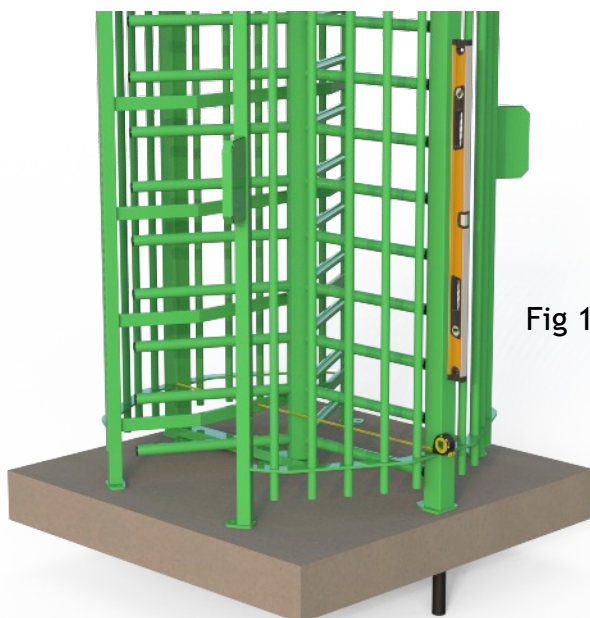
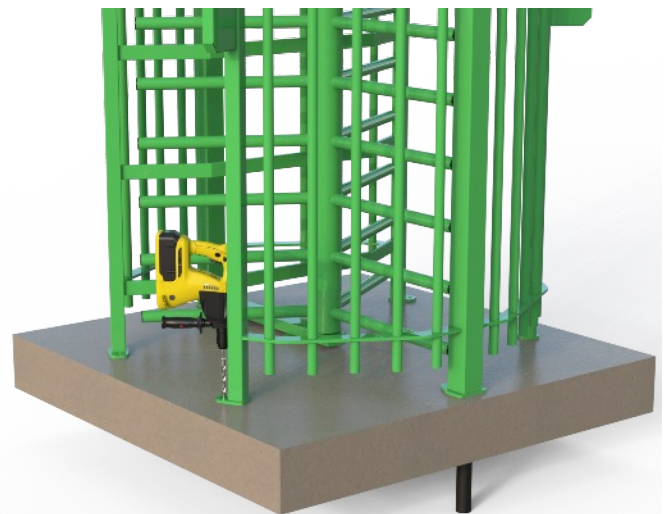
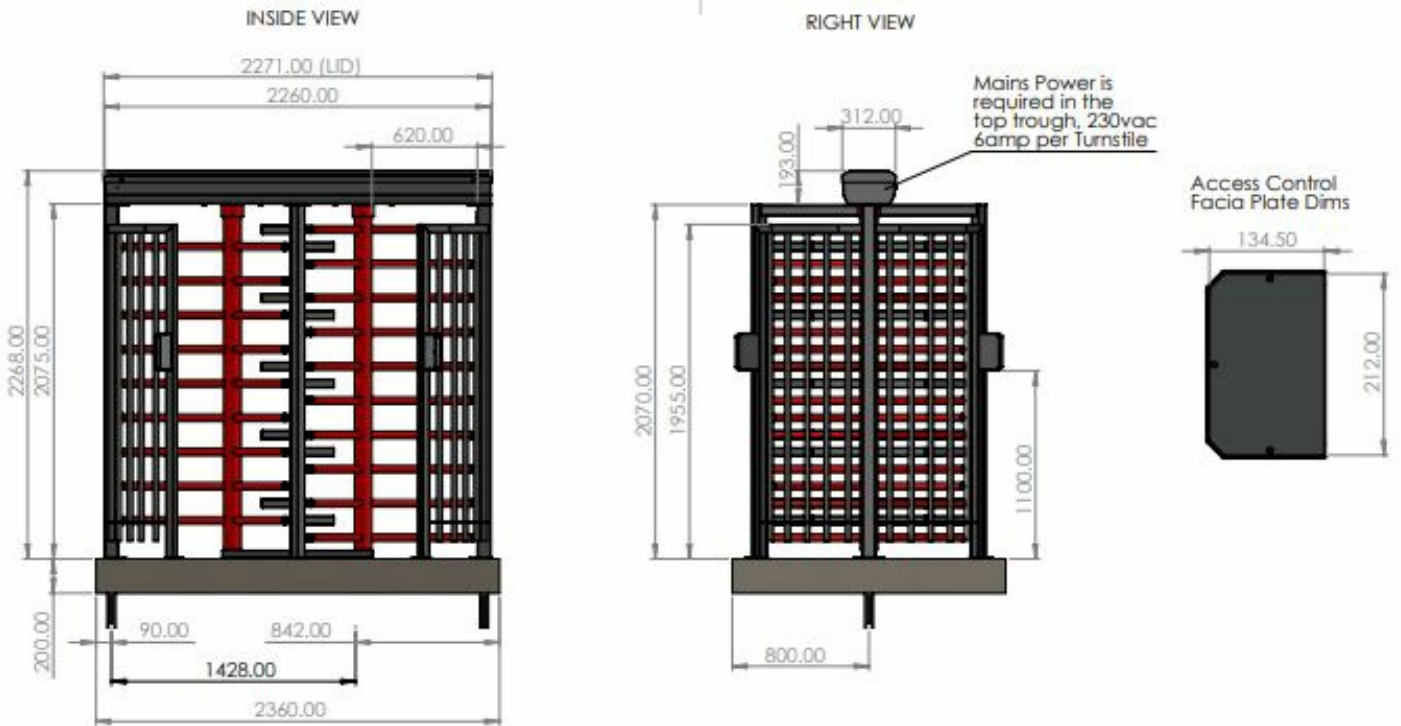
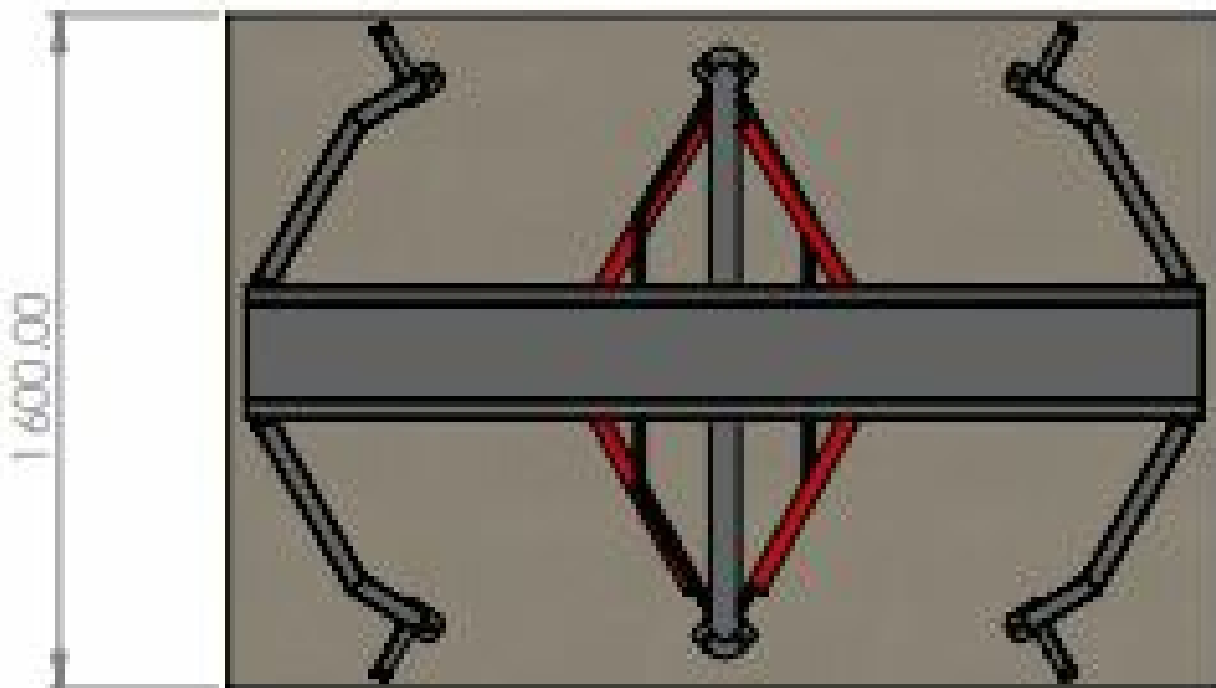

Fig 10





Plan View



## Step 1;

Lower the turnstile onto the prepared ducting whilst guiding any access/ mains supplies into the access underneath the main legs.

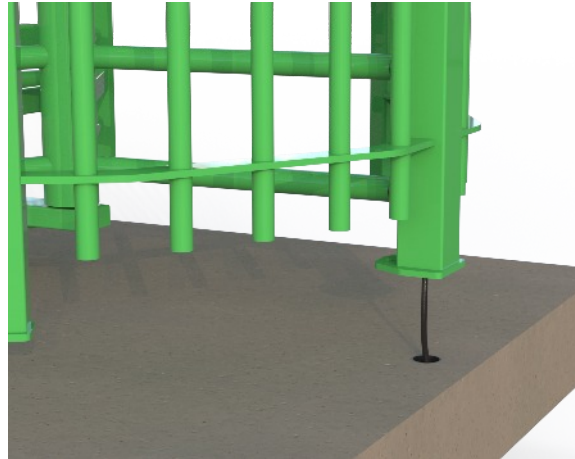

## Step 2;

Check the distances between rotar and leg all around to ensure the gap is equal and correct, also the distance between each leg, once you are happy with this you can continue to fixing the turnstile into position.

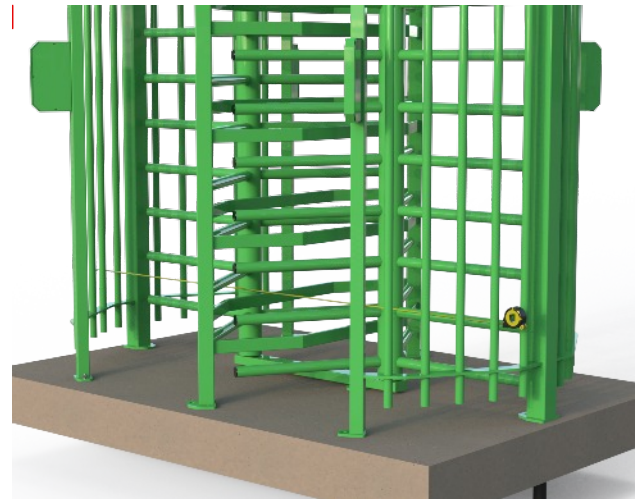
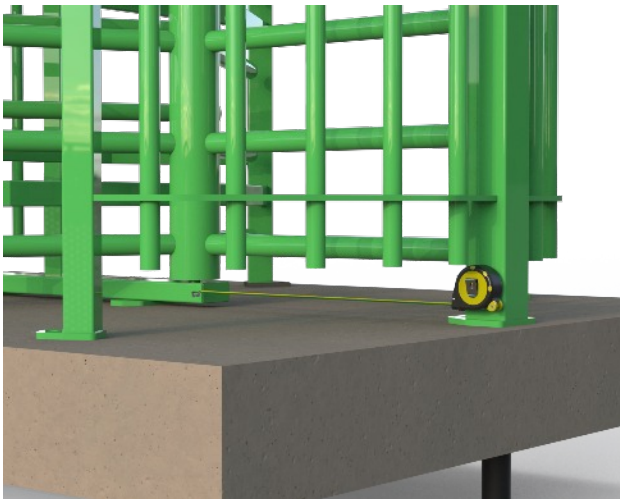

## Step 3;

The turnstile can now be bolted into place using a suitable m12 sds drill bit and drill with the anchor fixings provided, and tightened to the required torque using a suitable spanner or impact socket. At this point the levels can also be checked and adjusted slightly if required.

**(Please note turnstiles are designed to be installed on a clean and level base)**



RH Assembly

INSIDE VIEW

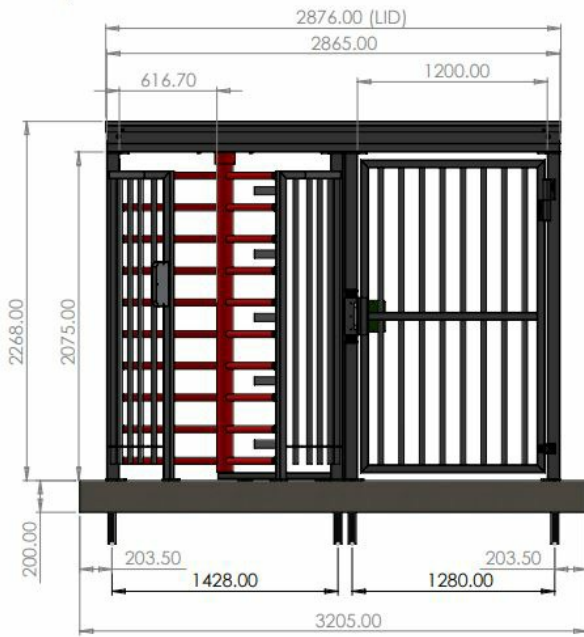

RIGHT VIEW

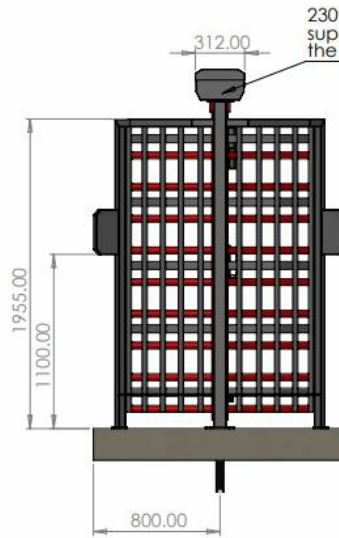

230vac 6amp Mains supply is required in the top trough.

Access Control Facia Plate Dims

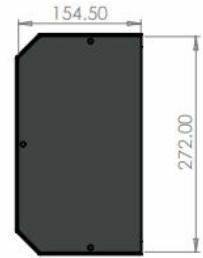

Note, The Pedgate maglock requires 12/24vdc to lock the gate, this is to be provided and controlled by the access control. The Maglock will require 1 AMP Max.

PLAN VIEW (Gate open)

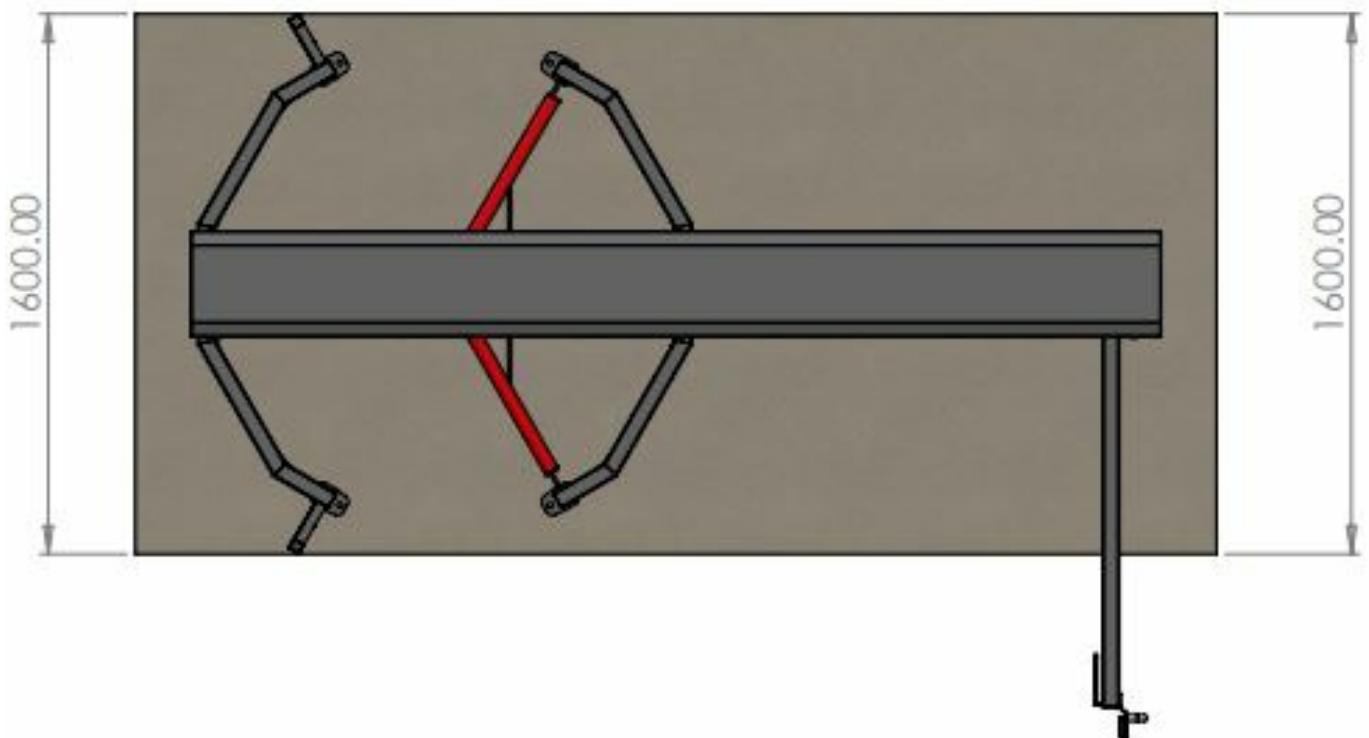

## Step 1;

Check the distance between legs to ensure correct alignment and aesthetics of your pedestrian gate, Once you have your cabling in place you can then move to Step 2



## Step 2;

The previous steps can be followed to finalise your integrated pedestrian gate install, once happy with your distances, the levels can be checked and adjusted slightly, before drilling the fixings using a suitable m12 sds and drill, the provided anchor bolts can be installed and correctly tightened using a suitable socket or spanner.



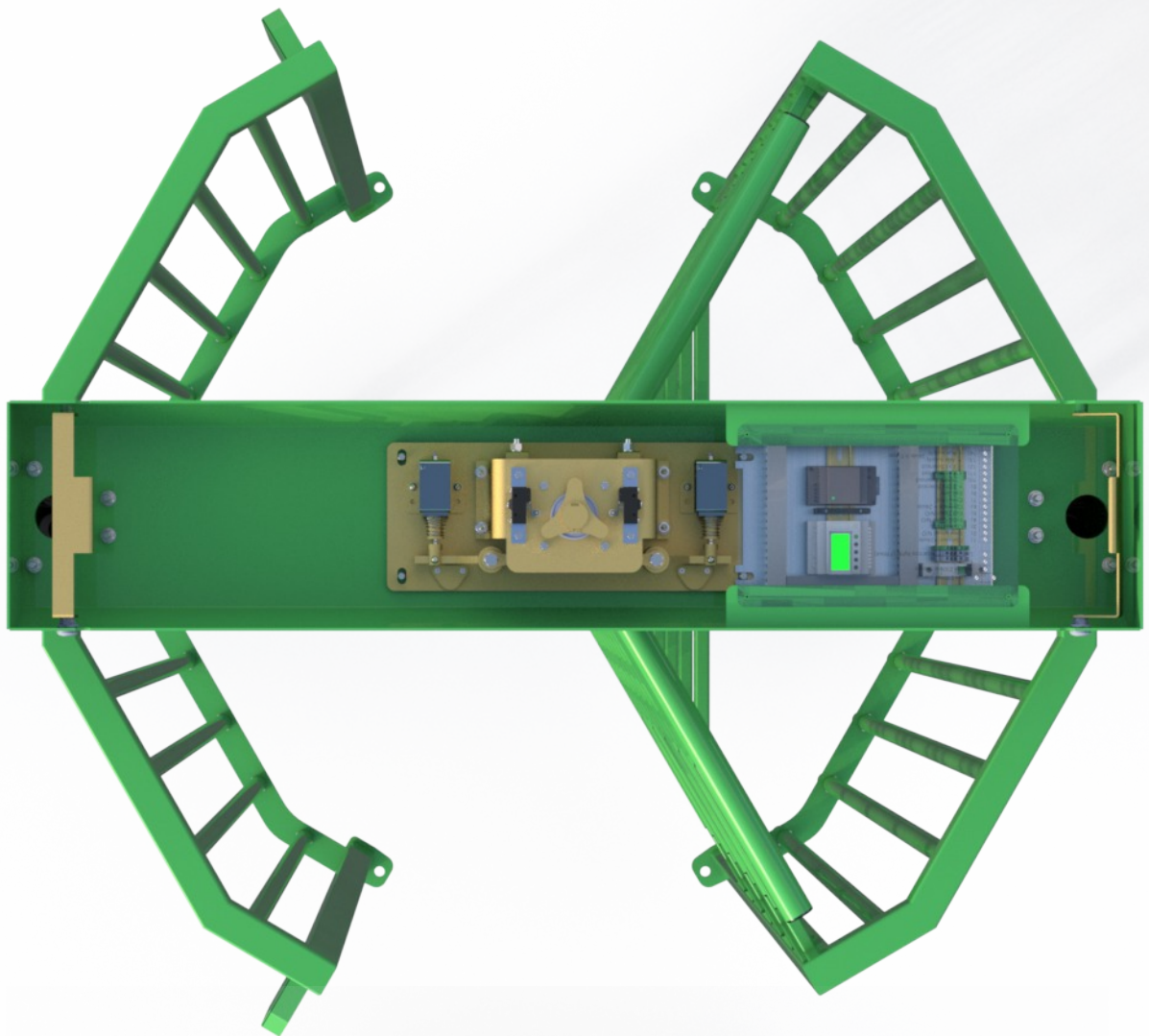

Plc

24v PSU

Mains Terminals

Terminal Rail

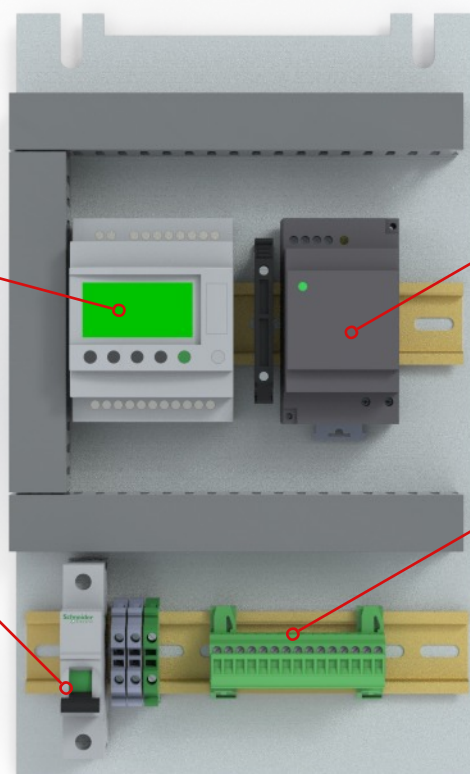

24VDC  
Power supply

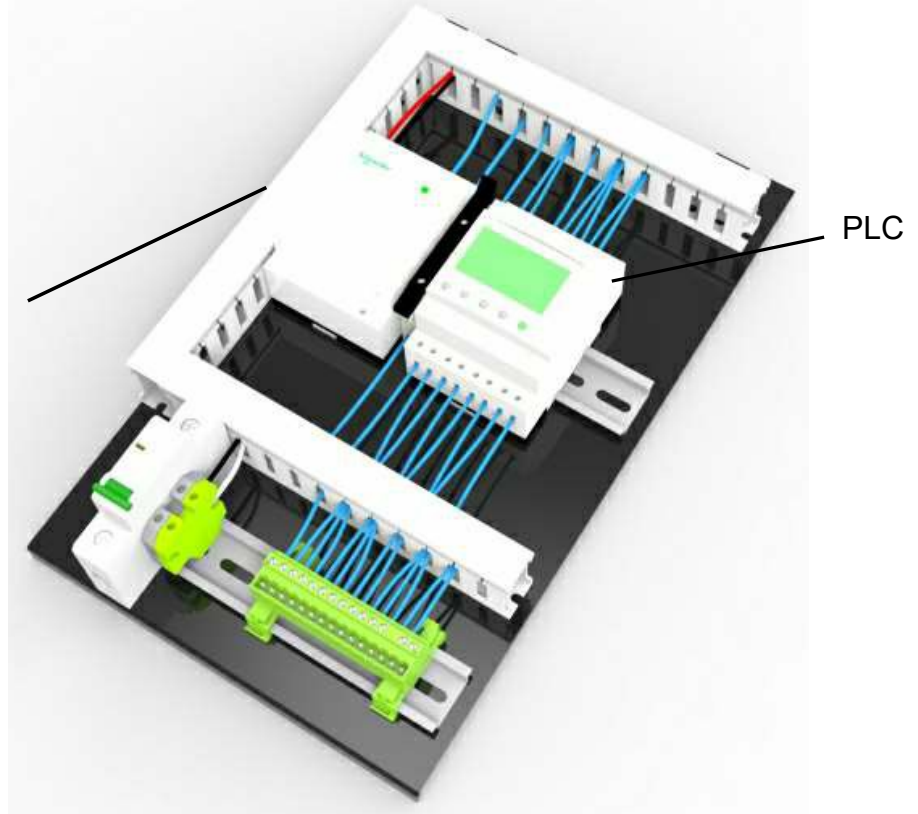

Live 230vac Supply



Neutral 230vac Supply



Earth



Live 230vac For canopy lights (if fitted)



1) Common +24vdc



2) Free wheel N/O



3) Locked N/O



4) Entry Open N/O



5) Exit Open N/O



6) Common + 24vdc



7) Entry limit



8) Exit limit



9) + Entry Solenoid



10) - Entry Solenoid



11) + Exit Solenoid



12) - Exit Solenoid

13) + Aux supply

14) - Aux supply 24vdc 0.5 amp

The turnstiles PLC has a display screen where you can change features and operate the turnstile.

To operate the display you simply use the arrows to navigate your way through the screen. There is a Menu/Ok key which will take you back to the home screen if you want to return.

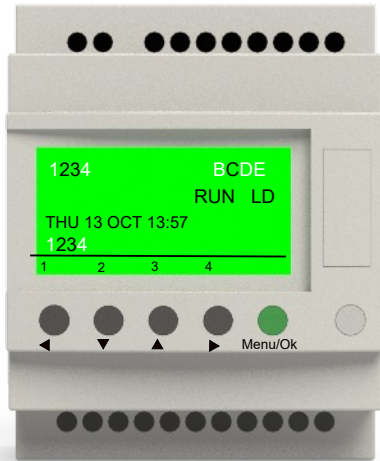

The home screen is always the first screen that appears after the Turnstile is powered up. You will only ever need to access operator interface to operate and change Timings for integrated down lighting.

The Screen to the left shows the turnstile in normal state, RUN LD shows the programme is running. The time and date can be seen and checked if correct. The inputs 1234BCDE can be seen and if active will be highlighted. The outputs 1234 can be seen along the bottom of the display again if highlighted these will be active. A full list can be found in the following pages of inputs and outputs explained further

## Down Light Time Settings

### Accessing Timers

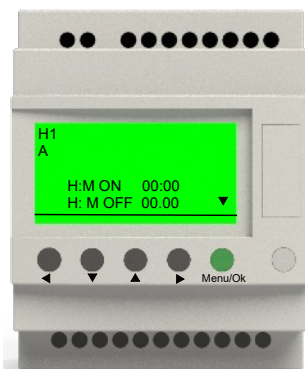

To access the timers press the menu key and access parameters Your first timer H1 is the timer for your down lights and will be preset to our factory settings for your convenience

To change simply navigate to the on / off times using the arrow keys (left and right) And alter using the up and down arrow keys.

Once you are happy with your new times simply press the green menu button to exit the parameters were you will be asked to save change select yes on exit and your lights will now be active during your new times

## Change Date and Time

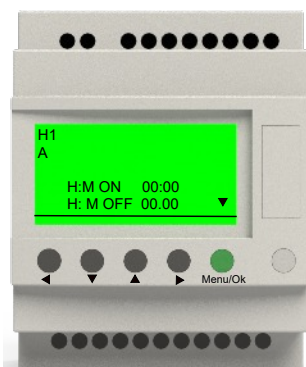

To Change the date and time simply follow the previous steps to access the menu, scroll down to change D/H and press ok to access. Then using the previous steps use the navigation keys to alter your time to suit.

Please use the following instructions to operate the barrier manually, the following is assuming you have powered down the unit and opened the cabinet door:

To Manually release the Turnstile, Turn the entry or exit key switch clockwise to release the rotor into free wheel. The key switches are located underneath the main header just above the rotor as illustrated below.



As stated at the beginning of this manual we recommend a bi-annual service, but at a bare minimum, it is imperative that you get a service done once every 12 months. This is not a sales tactic in disguise, there is a very serious health and safety issue/risk associated with not complying to this. Also in order for your equipment to keep complying with the appropriate legislation.

- Before carrying out any maintenance to the installation, Isolate the mains power supply.
- Make sure you have disconnected/Isolated the power before attempting any work.
- A Maintenance Contract should be sought from a specialist company after a maximum of 5000 manoeuvres or 1 year from the install date.
- Have a qualified technician (installer) check the correct setting of the electric clutch.
- If the power supply cable is damaged, it must be replaced by the manufacturer or its technical assistance service, or else by a suitably qualified person, in order to prevent any risk.
- When any operational malfunction is found, and not resolved, disconnect the mains power supply and request the assistance of a qualified technician (installer). When automation is out of order, activate the manual release to allow the opening and closing operations to be carried out manually.
- Bearing units are “sealed” for life and require no further lubrication.

Listed bellow are your plc inputs and outputs, along with a discription of the contact state and function of the relay.

1.Inputs			
Input	Polarity	Connected to	Operation when active
I1	Normally Open	Free wheel	Free wheels in both directions
I2	Normally Open	Entry signal	Allows one person through the entry of the turnstile
I3	Normally Open	Exit signal	Allows one person through the exit of the turnstile
I4	Normally Open	Entry limit switch	Switches solenoid off after one person is through
IB	Normally Open	Exit limit switch	Switches solenoid off after one person is through
IC	Normally Open	Lock signal	Locks the turnstile in both positions electrically
ID	Normally	Open Spare	
IE	Normally	Open Spare	
2.Outputs			
Output:	Polarity:	Connected to:	Operation when active:
Q1	Normally Closed	Entry Solenoid	Deactivates Entry solenoid
Q2	Normally Closed	Exit Solenoid	Deactivates Exit solenoid
Q3	Normally Open	Down lights	Controls down lights(if fitted) from Plc timeclock
Q4	Normally Open	Spare	



Note:

Depending which way the turnstile has been installed the entry/exit may be the opposite way round, This will not affect the operation in any way.

The turnstiles plc screen also acts as a fault guide depending on the input activated

Bellow are a few examples of the faults that can be found.



This example shows a fault on the exit limit as this is a normally open connection this will mean that the plc has sensed that it has a permanent signal from the entry limit the signal back has become closed. Advice now would be to check the limits operation and replace if necessary.



## Setting the barriers parameters



This example would show a permanent command from the access control unit to show the exit signal is permanently latched into the board, Fault rectification would include removing the access signal from the panel and checking for a closed circuit to the turnstile at this point the access can be checked should the circuit be closed. If the access is working as should (I.e a one second pulse) then further investigation into the panel would be required.



This example would show the free wheel option has been activated, this would be a fire alarm or emergency trigger into the plc allowing the turnstile to spin freely in either direction.



MECHANICAL ERRORS	CAUSE	CORRECTION
Turnstile is free wheeling	Paddles are not latched in	check manual release keyswitches
Rotor is not spinning	Check bearings top/bottom	Oil or grease bearings
Rotor has a lot of play when locked	Check paddle bolts	Tighten both paddle bolts
Turnstile making grinding noise	Top Cog/Spring assist requires lubrication	Lubricate both items
Turnstile Rotor is tight	Turnstile is out of square/level	check turnstile/frame is all square/level
Turnstile Rotor is tight	Bottom bearing is ceased	Replace bottom bearing
ELECTRICAL ERRORS	CAUSE	CORRECTION
Blank screen on PLC but power to other devices in the control panel	On-board fuse blown	Replace fuse and reset barrier
	PLC has developed an electrical fault or had a power spike	Change PLC
No 24DC to Plc or other devices	24V PSU faulty	Change PSU
	Blown fuse	Replace fuse
Turnstile Free wheels	If fail safe turnstile then solenoids may have no power	Check solenoid relay and replace if faulty
	If fail secure turnstile then solenoids may Have permanent power	Check solenoid relay and replace if faulty
Turnstile lets more then one Person pass through	Limit switches are not working	Adjust position of limit or replace if faulty
	Access control signal set too long	Turn access signal down to 1 second

## Declaration of incorporation

In accordance with BS EN ISO/IEC 17050-1:2010

**We:** Ultimation Direct Ltd

**Of:** Trent Lane, Maltkiln lane, Newark, Notts NG24 1HN In

accordance with the following directives:-

Supply of Machinery (Safety) Regulations 2008

Electromagnetic Compatibility Regulations 2016

The Radio Equipment Regulations 2017

Hereby declare that:

**Equipment:** Pedestrian Turnstile

**Model no:** D4150

Are in conformity with the applicable requirements of the following documents:

Supply of Machinery (Safety) Regulations 2008.

BS EN 12453:2017+A1:2021 Industrial, commercial and garage doors and gates—Safety in use of power operated doors— Requirements.

BS EN 12604:2017 Industrial, commercial and garage doors and gates—Mechanical aspects—Requirements and test methods.

BS EN 13241:2003+A2:2016 Industrial, commercial and garage doors and gates - Product standard. Products without fire resistance or smoke control characteristics.

BS-EN12978:2003 Industrial, commercial and garage doors and gates. Safety devices for power operated doors and gates. Requirements and test methods.

BS EN 13856-2:2013 Safety of machinery. Pressure sensitive protective devices. General principles for the design and testing of pressure sensitive edges and pressure sensitive bars.

I hereby declare that the equipment named above has been designed to comply with the relevant sections of the above referenced specifications. The unit complies with all applicable Essential Requirements of the Regulations.

Signed:

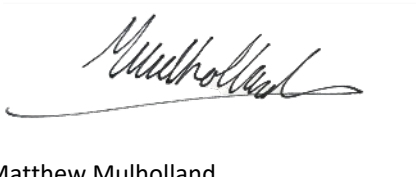

Name: Matthew Mulholland

Position: Technical Director

Place: Newark

Date: March 2026

We certify that the system covered by this certificate has been commissioned satisfactorily.

Site Name		Completion	
Site Reference		Engineers Installing	
Installation Commenced	/ /20	Commissioning	
Equipment Fitted			
Handover Date			

Part 2. Existing Installation Items not covered under warranty/ This certificate:

--

Part 3. Certificate Signing off Section

Installers Name		Signature	
On Behalf of		Date of Signing	
Address		Position	
Client Name		Signature	
On Behalf of		Date of Signing	
Site Address		Position	



This Manual must be completed in accordance with the guidelines below, at any point service/repair work is carried out on the product. This is to achieve two things;

1. To keep a history of the product for yourself and your supplier/manufacturer.
2. To keep an accurate log of any historical or recent modifications, and/or problems, to help an engineer in the event of any future work required on the product.
3. This page is continued on the next page if extra space is needed.

Date	Reason for visit/Action taken	Engineers Signature
/ /20		
/ /20		
/ /20		
/ /20		
/ /20		
/ /20		
/ /20		
/ /20		
/ /20		
/ /20		
/ /20		
/ /20		
/ /20		
/ /20		
/ /20		
/ /20		
/ /20		
/ /20		

Specification

Dimensions:

**Frame:** 1520 mm x 1360 mm x 2230 mm

**Rotor:** 120 mm Ø tube with bottom support bearing

**Arms:** 50 mm Ø tube with domed capped ends

**Side frames:** 50 x 20 Rolled Box section welded 80 box Uprights.

Specification

**Power Requirement:** 220 v, Single Phase, 50 Hz, 5 Amps

**Arms and body:** Primed/Powder Coated finish

**Duty Cycle:** 100% continuous duty rating

**Flow Rate:** 15 to 22/min in a single direction

**Key Points:** Bi-Directional control Fail safe or Fail secure, Factory settings need no adjustment, PLC controlled can work with all access and revenue systems, cable routes through side frames, Turnstiles will suit interior and exterior installations.

**Access Controls:** Push-button, Proximity cards, card readers, tokens, voice/video intercoms, keypads and remote fobs.

Accessories

Optional extras:

- Directional Flow indicator lights
- Canopy Lights
- Siren/Sounder
- Bespoke Signage

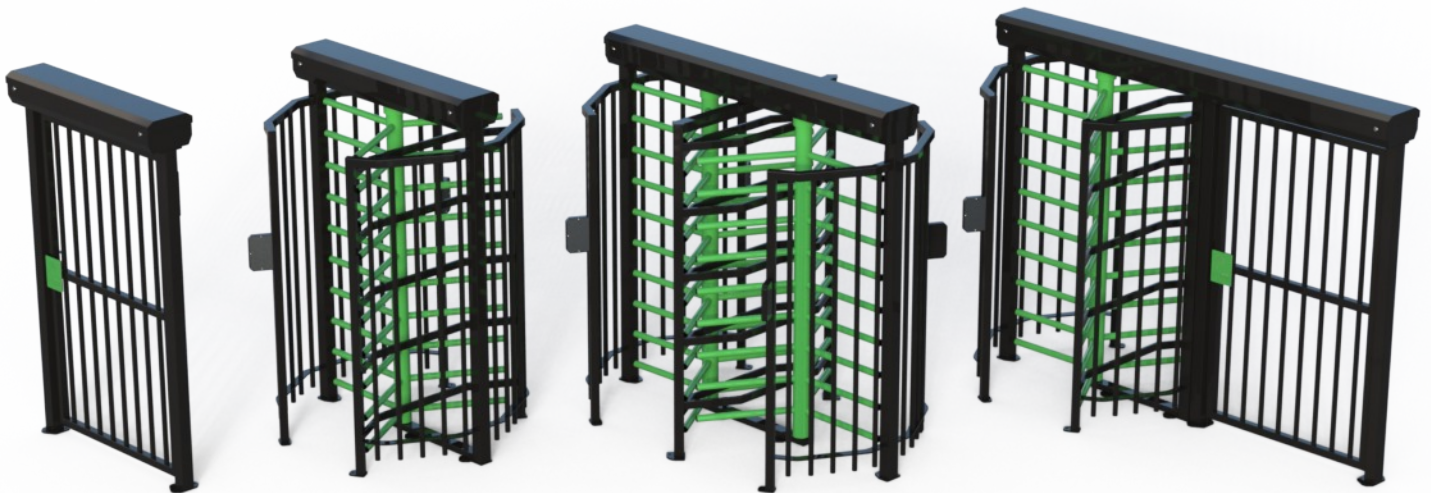

M a d e i n t h e U K

