

*O&M Manual
Revision 5.0*



D5400

Automatic cantilever sliding gate



1. Inductions and warnings	Page 03
2. Delivery, Movement and transport	Page 04
3. Lifting and handling	Page 05
4. General layout	Page 06
5. Installation	Page 07
6. Control Panel Layout	Page 18 - 19
7. Ancillary wiring	Page 20
8. Connection Diagrams	Page 21 - 22
9. Initial Set Up	Page 23 - 24
10. Auto Close	Page 25.
11. Parameters	Page 26 - 34
12. Manual Release	Page 35
13. Maintenance	Page 36
14. Service Log	Page 37
15. Commissioning Certificate	Page 38
16. Declaration of Conformity	Page 39
17. Technical Data	Page 40

This equipment is part of a large range of traffic flow products. They are designed to be easy to install, as all settings and internal wiring have been completed in our factory. Any of the instructions in this manual should only be carried out by a qualified service engineer or a competent person.

The Gates are ready to bolt down, connect to a single phase power supply and have any pre-cut loops wired into them (Please note that loop detectors are sold separately). The steps must be completed before the power is turned on to prevent accidents.

The following information is a guide only, and whilst we have made every effort to be accurate and correct there may be printing errors which we cannot be held responsible for.

With a correct installation you can expect to enjoy many years of reliable service from this product, we do however recommend that the product has a bi-annual service carried out by a qualified engineer. Please contact our service department to obtain a quote. As we manufacture the products we are best suited to care for your equipment.

Important Safety Notice



Automatic gates are designed to Control the flow of vehicular traffic only. It can be dangerous to allow the passage of pedestrians and any other self-powered animal or device to utilise this method of access without appropriate warnings and or signage.

It may be necessary for the end user of this product to provide an alternative, safe method of access to cater for the previously mentioned categories.

The end user should fit all necessary signage and warning notices to either side of the gate, which should be visible and clear from all directions of approach.

The product that was shipped to you was designed with a control program to protect all categories from harm or affect this however is only a safety precaution and should not be modified or tampered with by any unauthorised person not sanctioned by the manufacturer.

Please sign and date below to say that you have read and understood this notice before ANY installation work:

/ /20

The "Warnings" leaflet and "Instruction booklet" supplied with this product should be read carefully as they provide important information about safety, installation, use and maintenance.

Scrap packing materials (plastic, cardboard, polystyrene etc) according to the provisions set out by current standards. Keep nylon or polystyrene bags out of children's reach.

Keep the instructions together with the technical brochure for future reference.

This product was exclusively designed and manufactured for the use specified in the present documentation. Any other use not specified in this documentation could damage the product and be dangerous.

The Company declines all responsibility for any consequences resulting from improper use of the product, or use which is different from that expected and specified in the present documentation.

Do not install the product in explosive atmosphere.

The construction components of this product must comply with all applicable regulations and subsequent amendments. As for all non-EEC countries, the above mentioned standards as well as the current national standards should be respected in order to achieve a good safety level.

Information on using this manual



- ✍ Read all information thoroughly
- ✍ Pay attention to all safety advice
- ✍ Be aware of the symbols (shown above right and above left) as they have different meanings. One is an information symbol, the other a warning.
- ✍ There are many artists impressions of the product in this manual you should refer to the images as a guide only. **Professional CAD** drawings should be used as a reference drawing and nothing else. As before every effort has been made to be 100% accurate in this manual but we cannot make any guarantees.
- ✍ As we constantly innovate our products we may change the quoted spec and any other details that have been documented in this manual so you should always refer to the supplier to see if the manual that was shipped with your product is the latest edition.
- ✍ As with all electrical installations you should use a qualified electrician and obey all of the latest laws and regulations.
- ✍ Be sure to fill out and complete **ALL** paperwork where instructed as this manual is the equipments log book and maintenance manual.

The Company declines all responsibility for any consequences resulting from failure to observe Good Technical Practice when constructing closing structures (door, gates etc.), as well as from any deformation which might occur during use.

The installation must comply with the provisions set out by all applicable regulations and subsequent amendments.

Disconnect the electrical power supply before carrying out any work on the installation. Also disconnect any buffer batteries, if fitted.

Fit an omnipolar or magnetothermal switch on the mains power supply, having a contact opening distance equal to or greater than 3mm.

Check that a differential switch with a 0.03A threshold is fitted just before the power supply mains.

Check that earthing is carried out correctly: connect all metal parts for closure (doors, gates etc.) and all system components provided with an earth terminal.

Fit all the safety devices (photocells, electric edges etc.) which are needed to protect the area from any danger caused by squashing, conveying and shearing, according to and in compliance with the applicable directives and technical standards.

This article describes how your equipment will be delivered to you, specifications on the transportation used and advice including health & safety on movement of the equipment.



The manufacturer will use a qualified transport company to deliver the product conforming to the necessary regulations as detailed below:

- ✘ All drivers are qualified
- ✘ All drivers are tested once yearly (If applicable)
- ✘ All drivers carry risk assessments and method statements (available on request)
- ✘ They are controlled under law to conform as there are no trade regulation standards to comply with

Health and safety Considerations:

Moving Goods Safely (MGS) is a national project involving both the Health and Safety Executive (HSE) and Local Authorities (LA) working in partnership. The project aims to reduce injuries and ill-health arising from the movement of goods from supplier through haulier to the recipient and end user including any home deliveries. The project will focus upon the delivery and collection of goods and the hazards this generates. It covers the main areas that cause the majority of injuries and ill-health to workers, including:

- ✘ Workplace transport;
- ✘ Slips & trips, and;
- ✘ Musculoskeletal disorders (MSD).

The movement of goods presents us, as health and safety regulators, with the challenge of dealing with a huge variety of issues. The commercial organisations involved within the movement of goods are diverse including haulier, third party logistics providers, pallet networks, retailers etc, with some very large companies, thousands of small businesses and the self-employed. The movement of goods is more than just trucks on the road with a large proportion of accidents happening at the delivery/collection sites that are often not directly under the control of the company making the delivery or collection. Communication and cooperation problems can arise due to the many organizations involved in the movement of the goods, and this can also lead to difficulties in effectively managing health and safety.

(Source H&S Executive UK 2008)

The gates should ALWAYS! be moved with care and attention. The products are very heavy individually as well as a whole. You should not attempt to move this or any other products by unapproved handling methods.



WARNING

Always take safety precautions when lifting and handling heavy objects, in accordance with Manual Handling Operation Regulations 1992.

Always wear correct safety equipment in the vicinity of equipment being off loaded. The gate is to be steadied by means of ropes attached to each end of the gate; preventing it from swinging whilst being manoeuvred. It is important to use the correct nylon slings with a SWL of 2 tonne for each sling.

HANDLING

Due to the size and weight of most D5400 cantilever gates, the use of a mobile crane is required to offload and place into position.

All the D5400 gates come built up and are ready to lift straight onto the Concrete foundation, Once the Lorry has lifted the gate and placed it In the correct position you can proceed to bolt the gate down as shown in the installation on page 07.

A lifting plan must be done before any attempt to lift the gate into position, As sites vary this must be carried out by the installer prior to the gate being Delivered to site.





Diagram below shows a typical D5400 sliding gate highlighting the major parts.

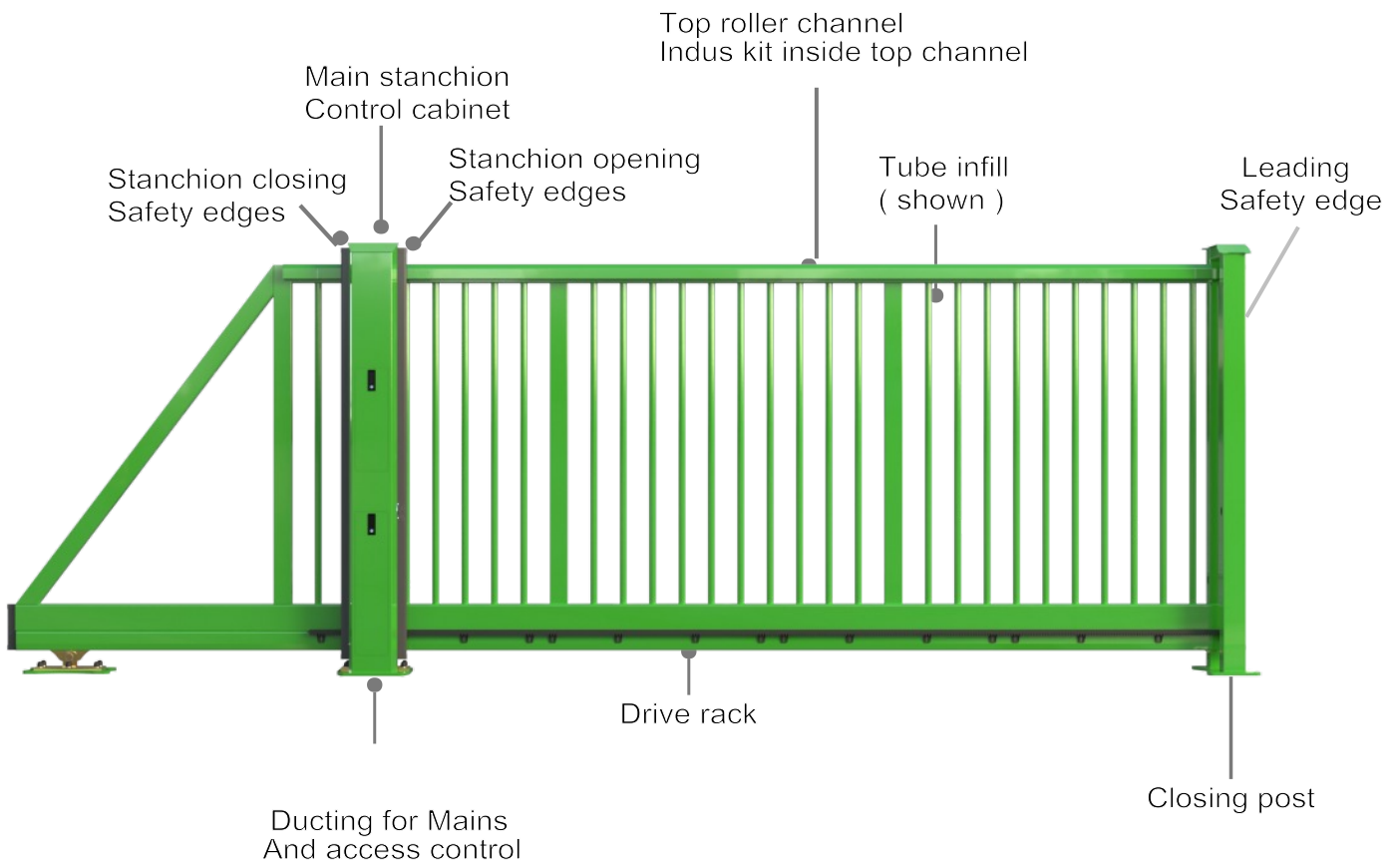



Foundations

All foundations should be installed as per drawing supplied as base size's will vary depending on the size of the gates. (Contact your supplier if you have not been issued one.) All foundations should be installed 10 x days prior to the gates being installed.

If details of the base have not been specified, we recommend a concrete mix to BS EN 206:2013+A2:2021 "Concrete specification, Performance, Production and Conformity" to type C35, which is equally suitable for external and internal environments.

The foundation must be positioned accurately and installed to the correct levels to ensure successful installation.



Careful consideration should be made when deciding the location of the gate to avoid overhead obstructions such as power cables, telephone wires building canopies, trees and other types of likely obstructions and hazards, which will not

Note; The main base contains 3 x ducts which require draw ropes to allow for easy access of the cabling to the gate main cabinet.

Duct 1 is connected across the opening to the closing post allowing easy access for the 24v dc to supply power for the photocells.

Duct 2 can be used to supply the mains power cable to the gate cabinet

Duct 3 can then be used as an access point for all access control cabling. Please note these must be all volt free contacts as our panels give +24v dc to receive it back from the access triggers.



Fixing Kits;

Once The gate is ready to install Please check through your fixing kit to ensure you have all bolts and accessories required. The Basic fixing kit will include;

- 1, 12 x m16 x 180mm Through bolts
- 2, 5 x m8 x 20mm Button head bolts with washers
- 3, 1 x Ramp
- 4, 1 x Catcher
- 5, 1 x Manual release key
- 6, 12 x m16 bolt caps
- 7, 1 x operation and Maintenance manual
- 8, 2 x Key switch keys
- 9, 2 x Cabinet keys



Please note, additional items such as loop detectors, remotes and traffic lights etc can be purchased as extras at the time of quotation or by contacting our spares department and will be issued as extras in your box of fixings.

Physical Installation.

With the gate lifted into position over the foundation, the following steps should be carefully followed to safely install your new gate.

Step 1. Lowering the gate onto the foundations.

Before the gate is lowered into position, the surface of the foundation should be swept clean of any particles or contaminants. The position of the incoming ducts to the stanchion should also be measured with reference to the foundation edges to ensure they are exactly as shown on the supplied drawing.

Carefully lower the gate onto the foundation (figure 1), and ensure the ducts are aligned with the aperture in the stanchion base plate, (figure 2). Keep the HIAB attached to the gate for the time being.



Figure 1



Figure 2

Step 2. Removal of Transportation Stops and Plate.

To allow safe transportation the gate, it is fitted with 4 mechanical stops to ensure no movement whilst the gate is being lifted into place.

These can be found at each side of the station and either side of the roller, Please note 2 of these may be needed upon set up as the roger motor is encoder driven it will require an open and close stop fitted at the end of each travel for its initial set up.

These will need to stay in place although the motor will remember its positions and stop slightly short of these points when set up should the power be lost for a considerable length of time the motor will auto reset its positions and again uses these stops as reference points.

The stops can be initially removed with a 17mm spanner or socket which will remove the tapped M10 bolt and allow the clamp sections to separate and be removed, One side of this plate clamp will be found in the drive track. Fig 3.

There will also be 1 metal clamp under the station roller to keep the station straight during transport. This can be removed by taking the bolt out using a 5mm alan key and then slid out fro under the wheel allowing the cantilever movement. Figs 4 and 5

Figure 3

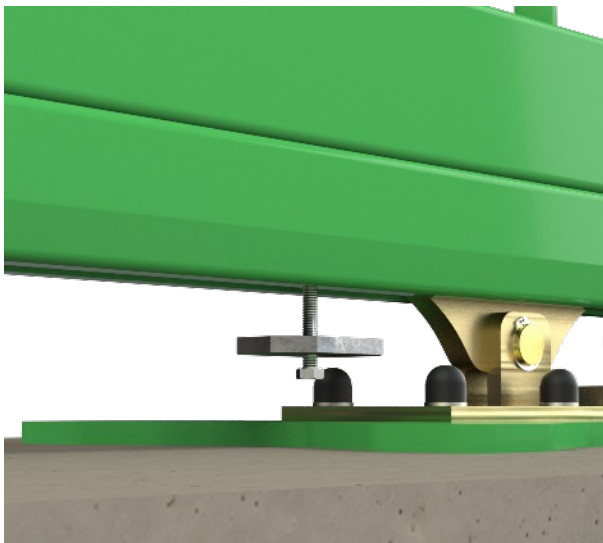

Figure 4

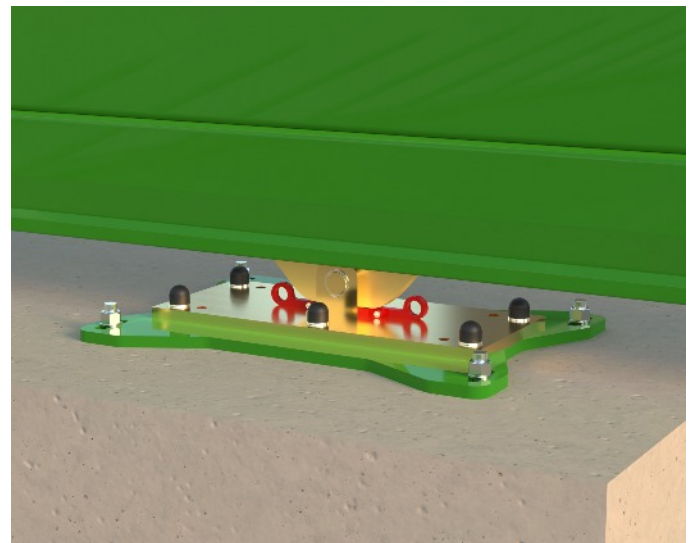
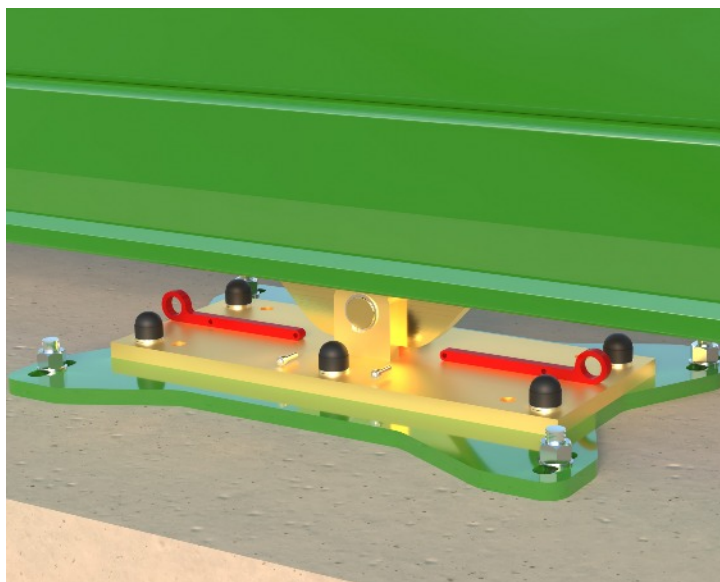

Figure 5



Step 3 Positioning the Rear Roller and Aligning the Gate.

Using the attached HIAB crane, relieve the weight of the gate on the rear roller assembly until it is possible to slide the roller along the gate roller channel.

Using a tape measure as reference, carefully move the rear roller carriage along the foundation until it is at the correct distance from the rear of the stanchion base plate. As shown on the provided drawing. Note. This measurement needs to be accurate to ensure proper operation of the gate. See figure 5.

Using a string line or laser, check the alignment of the gate in relation to the foundation and closing post location and adjust as required. Figure 6.



Figure 5

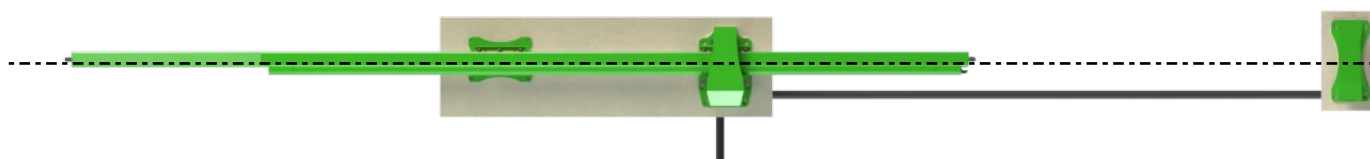

Figure 6

Step 3 Positioning the Rear Roller and Aligning the Gate - continued.

To ensure that the gate is in the correct location with reference to the closing post, measure the distance from the rear of the cantilever section to the rear of the Roller Plate (figure 7), and ensure that this dimension is greater than the measurement between the front of the gate leaf and the centre of the closing post foundation (figure 8). This is to make sure that the distance the gate leaf has to travel to be fully closed is less than the amount of travel available.

Finally a check must be made to ensure that the rear roller and stanchion are perfectly aligned along the centre line of gate travel (figure 9). Any misalignment of the stanchion or rear roller should be eliminated to allow the gate to travel freely (misalignment will cause noise in operation and undue wear to the rollers gate channel and drive system).

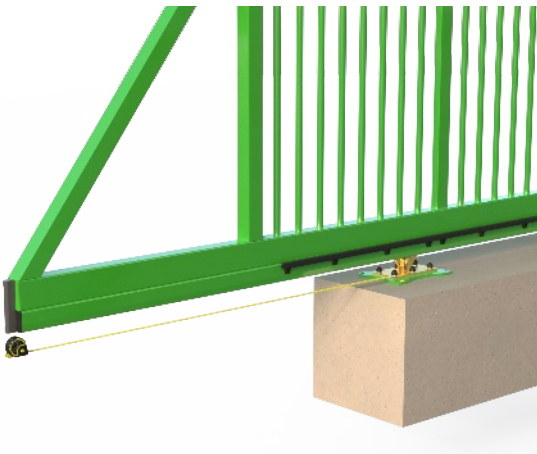

Figure 7

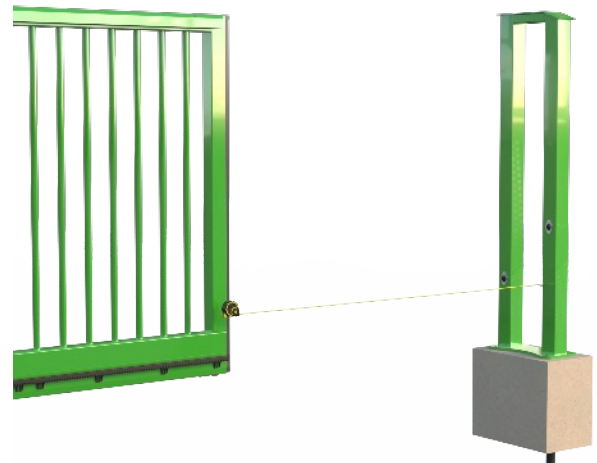

Figure 8

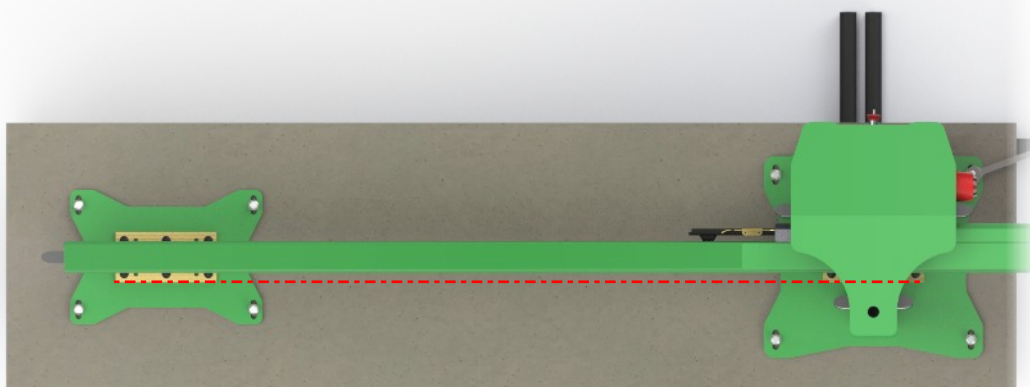

Figure 9

Step 4. Bolting Down to the Foundation.

When happy with the gate placement and alignment, drill the fixing holes for the rear roller into the foundation using a suitable M16 drill. Brush away any concrete dust and then insert all four fixings, drive them fully home with a hammer and then tighten fully using a suitable wrench. Figures 10a & 10b.

At this stage, re-check the alignment of the whole assembly, and ensure that the stanchion and rear roller are still perfectly aligned with the centre line of the gate. The fixing holes for the stanchion can now be drilled, and hold down bolts installed and tightened as per the above procedure. Figures 11a & 11b.

Finally, re-check the position and alignment of the closing post, then drill and bolt down as above. (Figure 12).



Figure 10a



Figure 10b

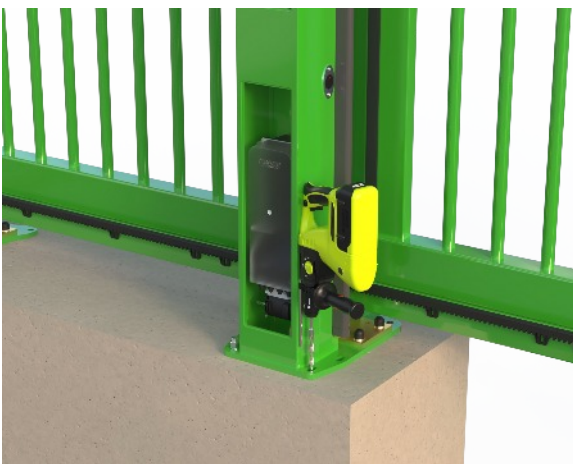

Figure 11a

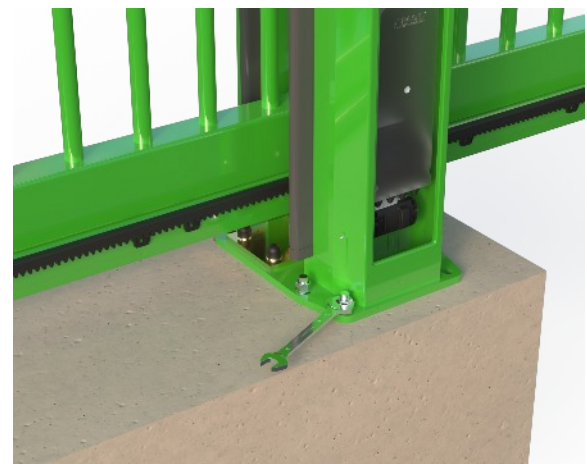
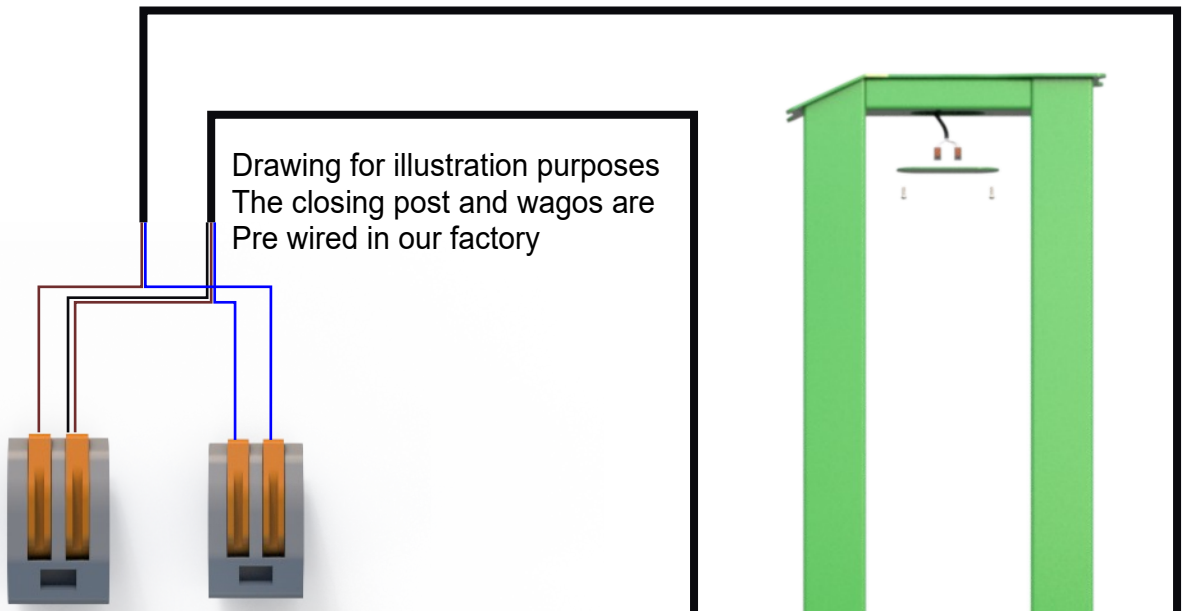

Figure 11b



Figure 12

Step 5;



Please note the internal photocell is pre wired to Channel two via the black being added with the Positive connection

The grey terminal blocks can be found
In the gate main station.

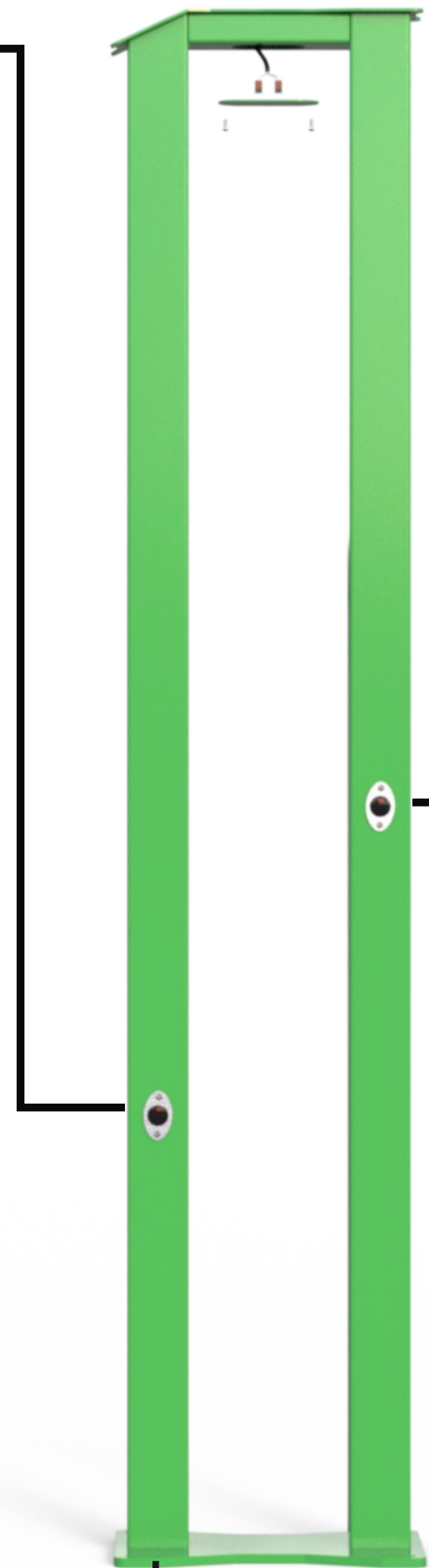

Step 6 Closing post

Figure 17

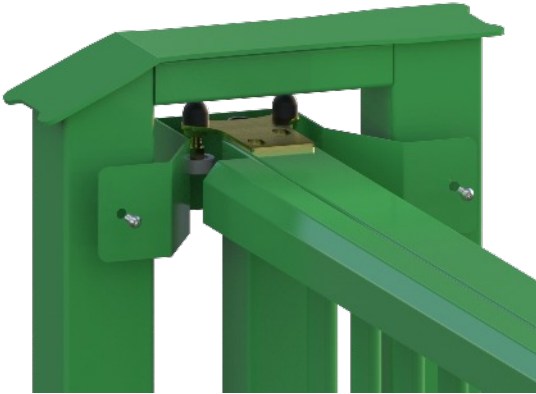

To install the catcher fully close the gate and offer the catcher up to the closing post so that the guide wheels are fully covered by the catcher guide. See figure 17

Drill the closing post once you have marked the catcher holes with a 7mm hss drill bit this can then be tapped with an 8mm tap and secured using the provided m8 bolts and washers using a 5mm Alan key. See figure 18

Figure 18



Figure 19

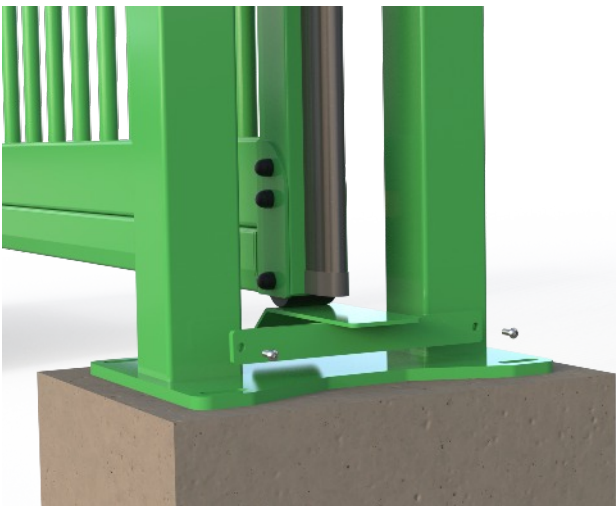

The ramp is installed by closing the gate and offering the ramp up to the front guide wheel. Then making a mark where the ramp sits. As this is a resting point for the cantilever gate and will support some of the weight it is suggested that the gate is rolled back prior to drilling and the ramp lifted approximately 3mm from the marked position. This again can be attached with a 7mm hss drill bit and 8mm tap. And using the supplied m8 bolts and washers. See figure 19.

Step 7 Adjusting the racking

The Drive rack is set in our factory for testing and alignment however. This can become loose or out of alignment due to the transport process. It is therefore the responsibility of the installer to complete the final check to ensure the correct alignment with the drive cog through the full length of the gate.

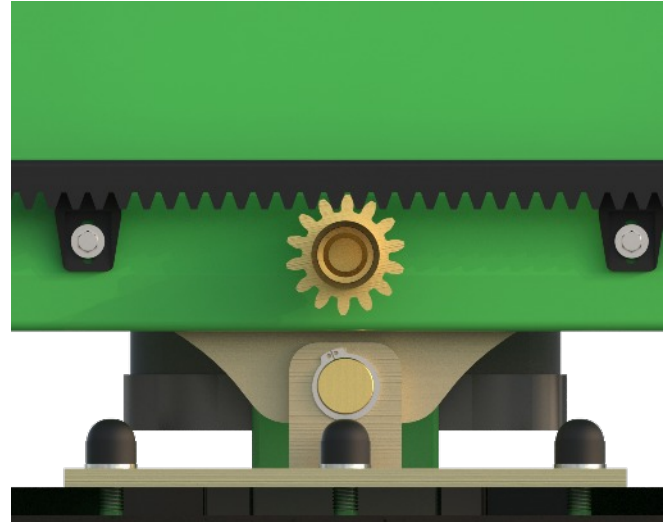

The desired gap between the drive cog and racking is 1 to 2mm for the length of the gate. The Drive rack is supplied with slotted holes to make adjustment easier and should always be done with the gate in manual operation.

The best practice for setting this racking is done 1 x section at a time. The m6 hex bolts can be loosened using a 10mm socket and the gate rolled from across the section whilst ensuring the gap stays the same. Once happy with each section the bolts can then be tightened to ensure correct operation of the gate once it is fully automated.

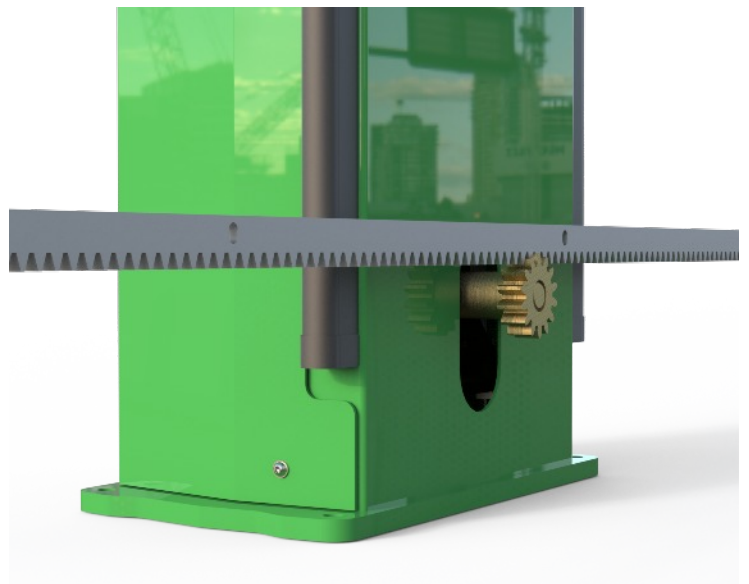

Please now lock the motor back in to automated running
 This can be done with your manual release Key.
 This should be hand turned till you feel resistance then move the gate slightly to ensure the lock has engaged properly.



Now that your gate is fully mechanically installed it
 Is now time to connect your mains supply. This is 230 v 16 amp
 single phase supply.

Please Note this supply must be installed and connected
 By a fully qualified electrician and must confirm to BS 7671:2018+A3:2024 and be fully tested
 To ensure minimal earth leakage. As our gates are inverter driven and the inverter
 Itself contains earth leakage filters the supply must be connected
 And tested properly and installed from an mcb as apposed to an rcd.
 Failure to do so could result in improper function of your gate and therefore alter the gates
 Ability to comply with all current regulations.



Mains isolator

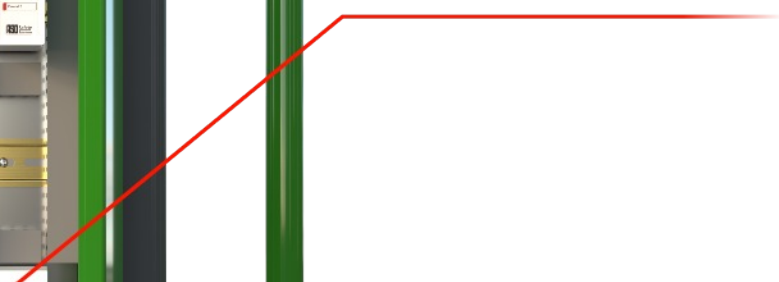

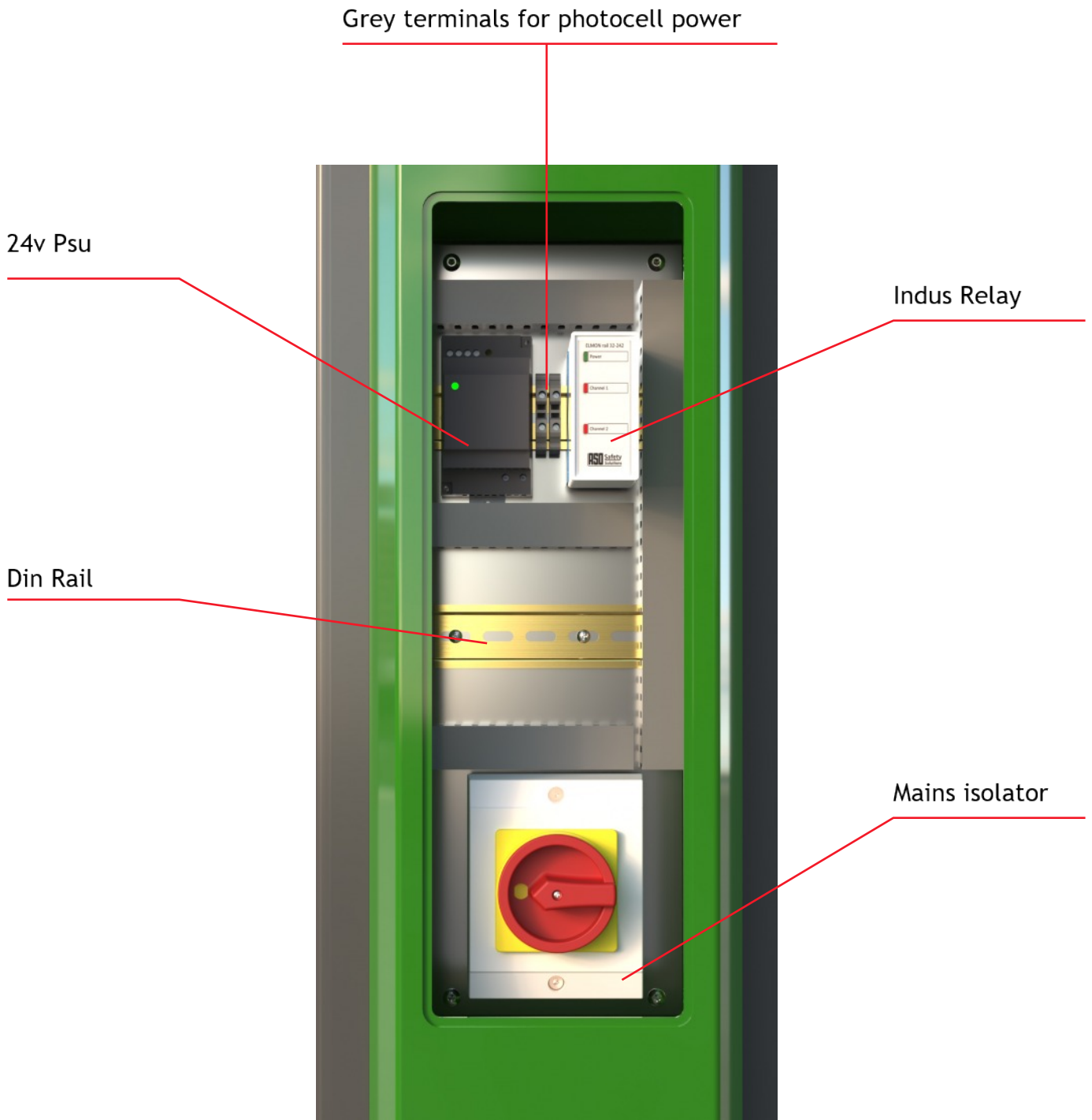

Above shows the layout of a D5400 top panel which will help identify any main components.

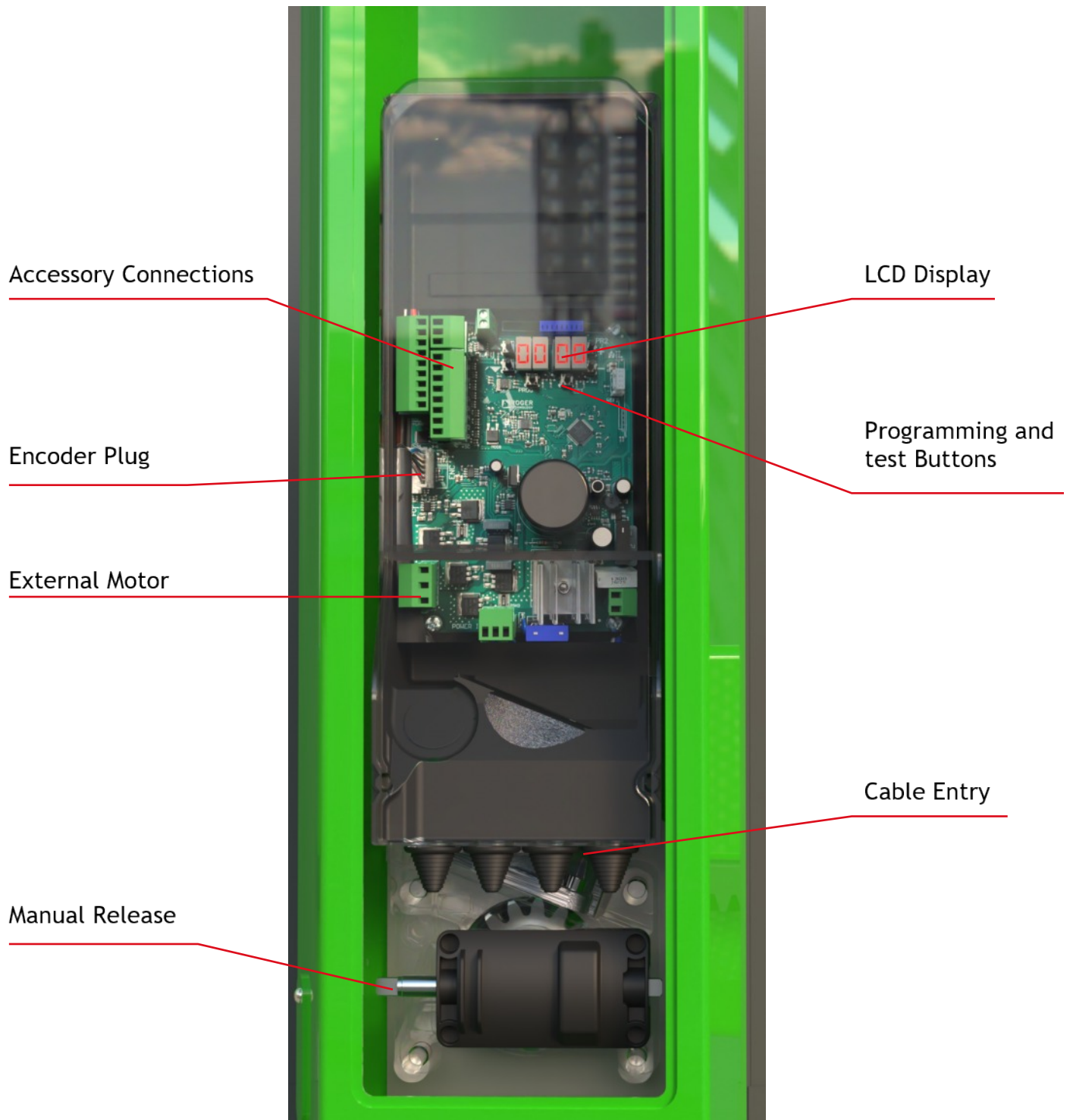

Above shows the layout of a D5400 gate panel which will help identify any main components.

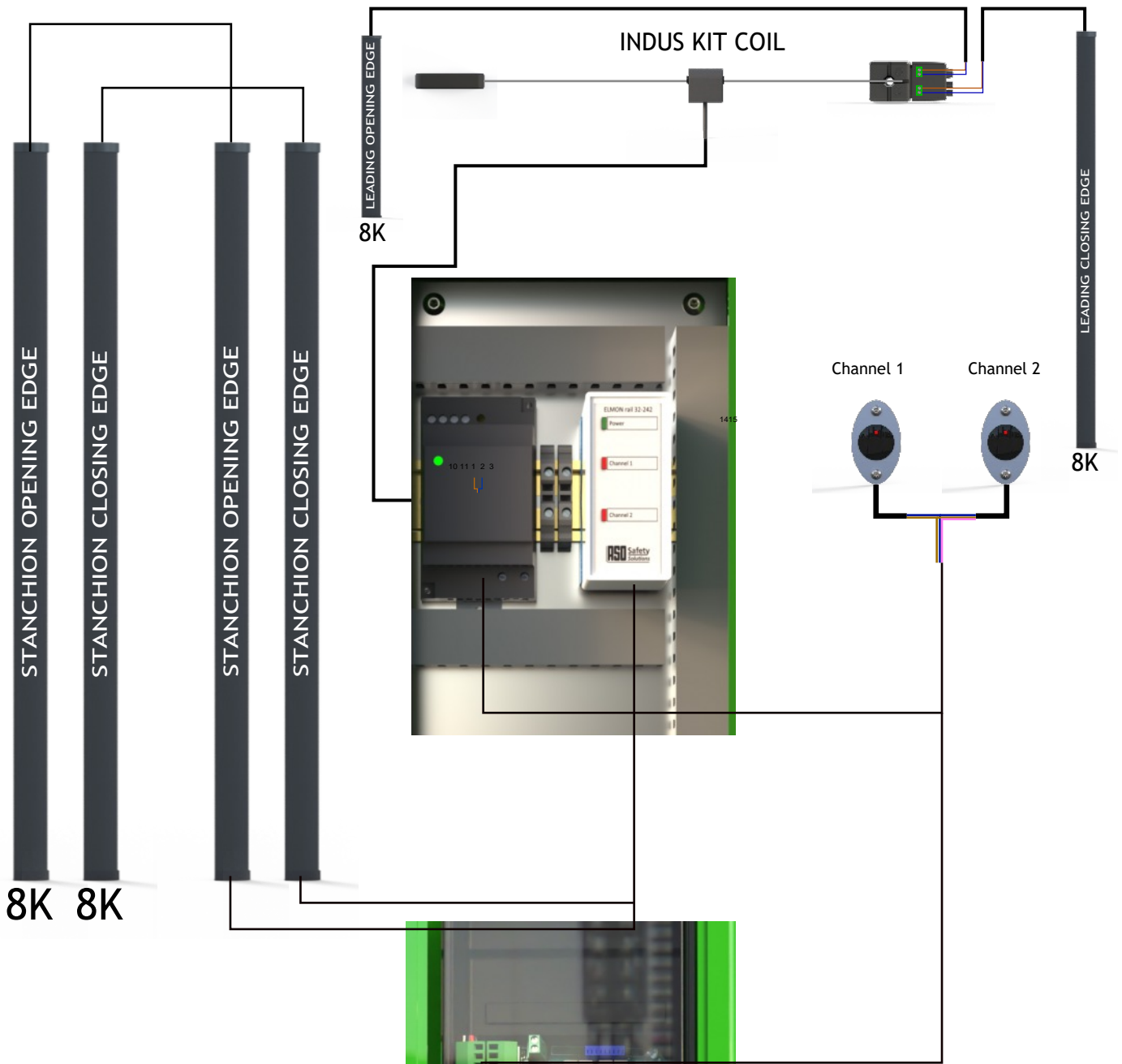

FW
r2.10

HW
02

Dispositivo IP B74/BCONNECT
B74/BCONNECT IP device

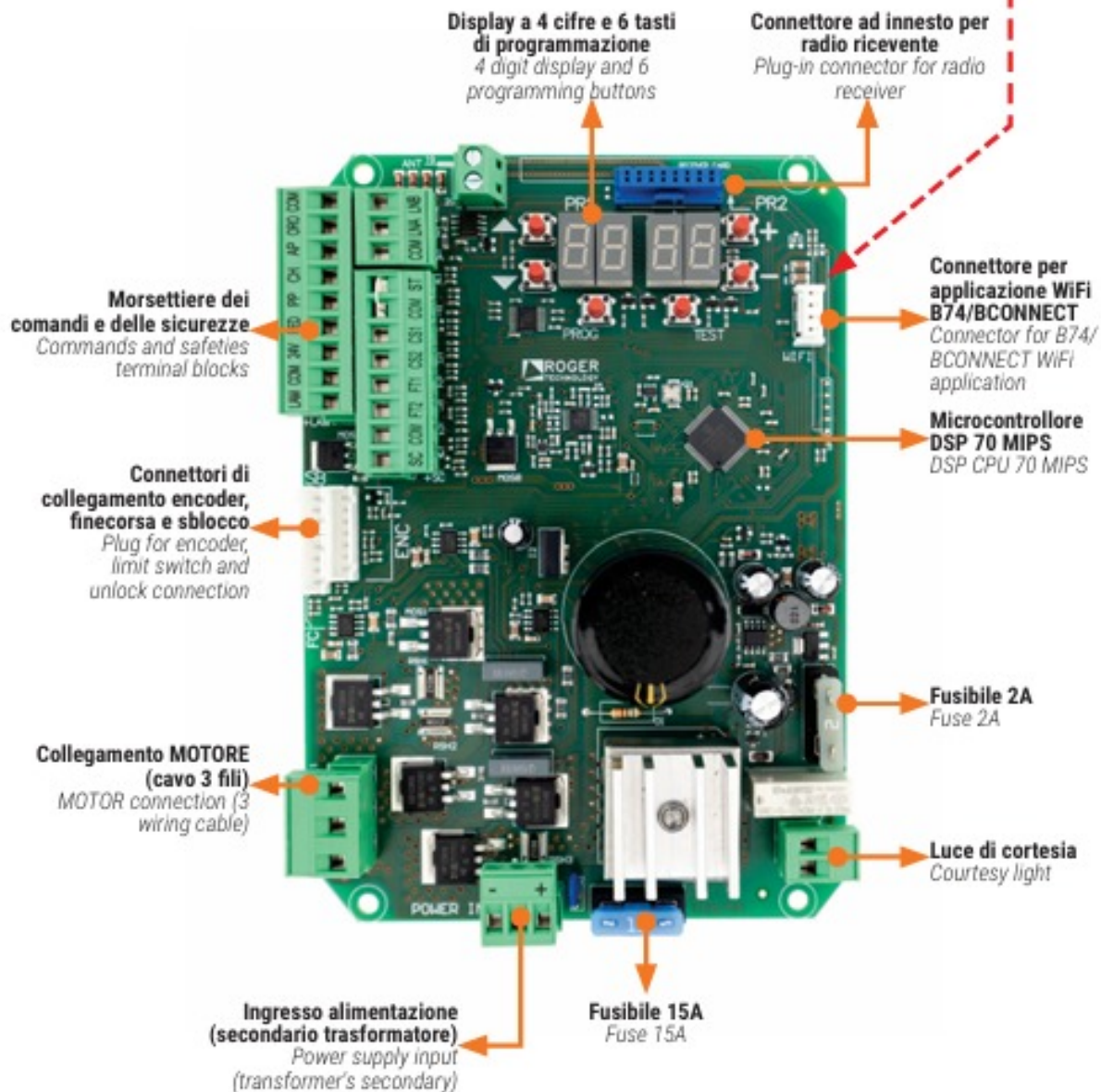

The Bellow connections can be found inside the lower motor panel.

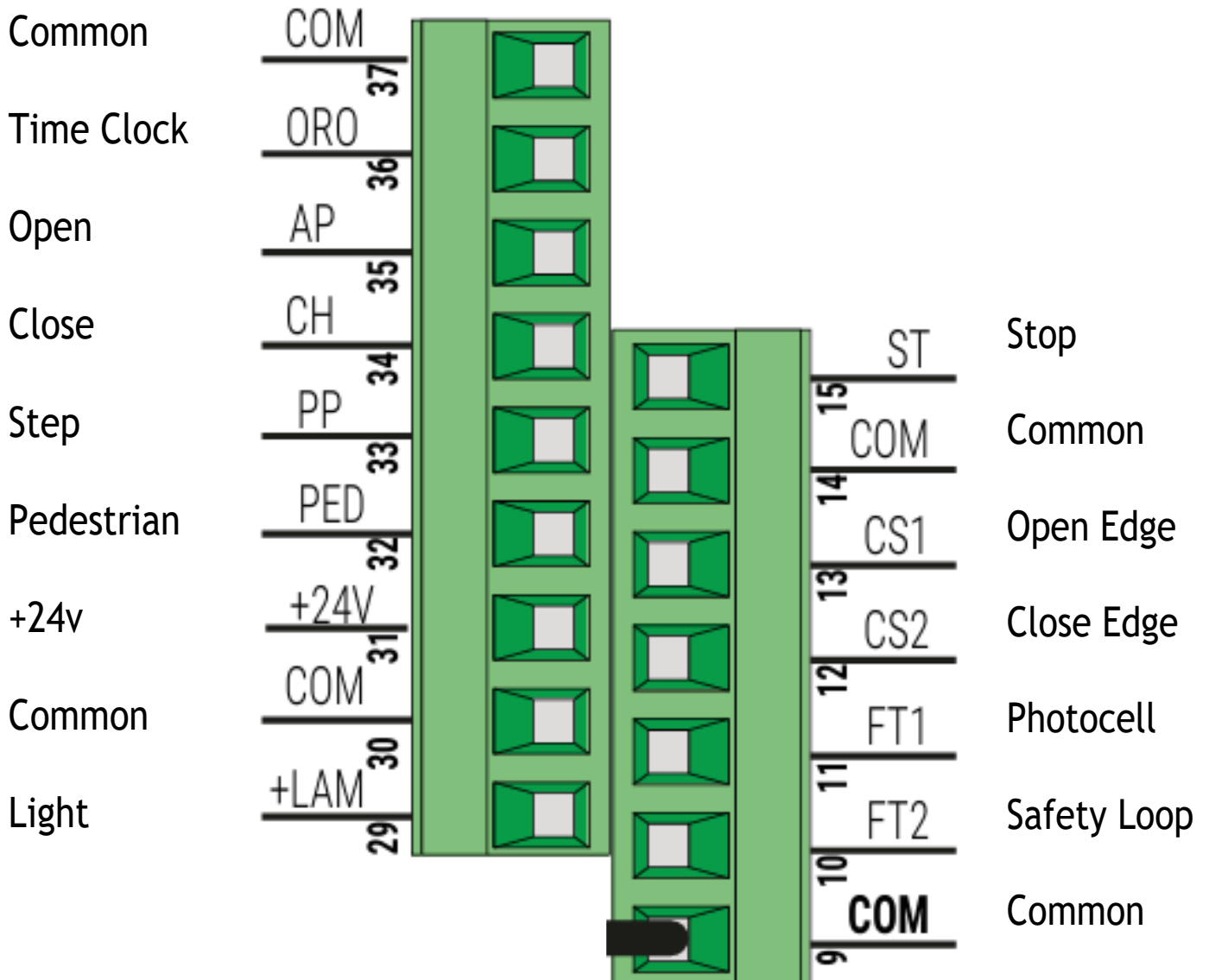

Please note the photocells and edges have been pre wired and inputs set for the correct logic, any changes to these settings or wiring could result in incorrect use age.

When you have the gate powered and ready to run please follow the next few steps to initially set up your encoder run positions. This will only need setting once.

BUTTON	DESCRIPTION
UP ▲	Next parameter
DOWN ▼	Previous parameter
+	Increase value of parameter by 1
-	Decrease value of parameter by 1
PROG	Travel acquisition
TEST	Activate TEST mode

To navigate the autoset on the roger control board please first press the test button to ensure no faults are present as these will cause the autoset to fail.

Note; The autoset must be started with the gate in the fully closed position.

00	No safety device in alarm state and no limit switch activated.
5b (Sb)	Release pin rotated.
15	STOP contact (N.C.) open. If there is no STOP switch, jumper the contact.
13	Sensing edge contact COS1 (N.C.) is open. Check connection. If sensing edge is not installed, disable with 73 00.
12	Sensing edge contact COS2 (N.C.) is open. Check connection. If sensing edge is not installed, disable with 74 00.
11	Photocell contact FT1 (N.C.) is open. Check connection. If photocell is not installed, disable with 50 00.
10	Photocell contact FT2 (N.C.) is open. Check connection. If photocell is not installed, disable with 53 00.
FE	Both limit switches in error state. Check connections and settings of limit switches.
FR	If automation is open, open limit switch is detected.
FC	If automation is closed, closed limit switch is detected.

If needed the settings for each input can be found over the next few pages to assist with fault rectification, Once the test reads 00 the product is ready to autoset.

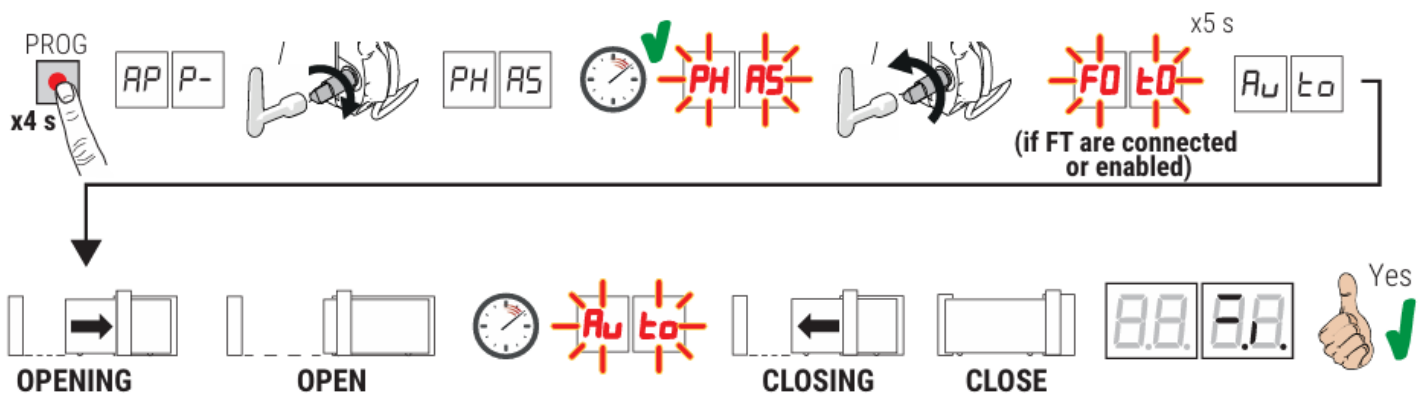

- With the gate in the fully closed position Press and hold the programme button for 4 seconds until APP- appears
- Turn the manual release pin with the key clockwise until PHAS appears on the display
- When the message PHAS starts to flash the key can then be turned to the locked off position again
- Should the set up be successful the motor will display AUTO and begin to open at slow speed.
- The gate will stop briefly in the fully open position and AUTO will flash on the display
- The gate will then start to close at slow speed until the closing travel stop is encountered.
- Once the gate is fully closed it will back off slightly creating its end stop point just short of the travel stop.
- The gate is now set up and ready to test.

If the following messages appear then the fault must be cleared and the acquisition procedure re-started.

- No PH : Calibration mode failed
- AP PE : Acquisition error, press the test button and clear the error state before proceeding to auto set again
- AP PL : Travel position length error, Press the test button to clear and ensure the gate is fully closed before trying again.



Auto close options explained;

The auto close functions can be accessed through the parameters menu, For the no passage timer A2 will need to be set to 99 this means that the board will continue to try to close up to 99 times before it fails to auto close should the photocells be triggered etc whilst trying to close, Alternatively this can be set lower should you wish the gate to stop trying in fewer movements.

Parameter 21 can then be accessed to set the auto closing time desired, Please note once the setting reaches 99 this will then count in minutes.

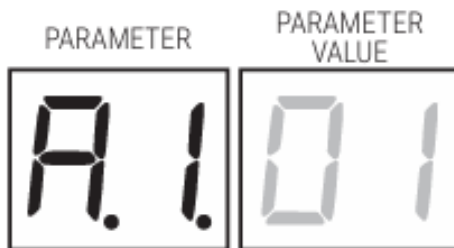



A101	Selecting automation system model WARNING! If this parameter is not set correctly, the automation system may not function properly. N.B.: in the event of a reset to restore the default parameters, this parameter must be set again manually.	
01	TW90/800 - TW90/820 - IRREVERSIBLE motor for gate leaves up to 800 kg.	
02	TW90/600/HS - TW90/620/HS - IRREVERSIBLE motor for gate leaves up to 600 kg.	
03	TW90/800/R - TW90/820/R - REVERSIBLE motor for gate leaves up to 800 kg.	
04	WAY/004 - IRREVERSIBLE barrier with boom up to 4 m.	
05	WAY/005 - IRREVERSIBLE barrier with boom up to 5 m.	
A200	Automatic closure after pause time (from automation completely open)	
00	Disabled.	
01-15	From 1 to 15 of automation closure attempts after photocell is triggered. Once the number of attempts set is reached, the automation remains open.	
99	The automation tries to close indefinitely.	
A300	Automatic automation closing after mains power outage	
00	Disabled. The automation does not close automatically when mains power is restored.	
01	Enabled. If the automation is NOT completely open, when mains power is restored, the automation closes after a 5 second warning signalled with the flashing light (independently of the value set with the parameter A5). The automation closes in "position recovery" mode (see chapter 21).	
A400	Selecting step mode control function (PP)	
00	Open-stop-close-stop-open-stop-close...	
01	Condominium function: the automation opens and closes after the set automatic closing time. The automatic closing timer restarts if a new step mode command is received. Step mode commands are ignored while the automation is opening. This allows the automation to open completely and prevents the automation from closing when not required. If automatic closing is disabled (A200), the condominium function automatically attempts a closing manoeuvre A201.	
02	Condominium function: the automation opens and closes after the set automatic closing time. The automatic closing timer does NOT restart if a new step mode command is received. Step mode commands are ignored while the automation is opening. This allows the automation to open completely and prevents the automation from closing when not required. If automatic closing is disabled (A200), the condominium function automatically attempts a closing manoeuvre A201.	
03	Open-close-open-close.	
04	Open-close-stop-open.	
A500	Pre-flashing	
00	Disabled. The flashing light is activated during opening and closing manoeuvres.	
01-10	Flashing warning signal for 1 to 10 seconds prior to every manoeuvre.	
99	5 second flashing warning signal prior to closing manoeuvre.	
A600	Condominium function for partial open command (PED) NOTE: parameter A6 is not displayed for WAY automations because the PED command is not managed	
00	Disabled. The automation opens partially in step mode: open-stop-close-stop-open...	
01	Enabled. Partial commands are ignored during automation opening.	

A7 00	Enabling operator present function NOTE: enabling the dead man function prevents GAPT mode (par.80).
00	Disabled.
01	Enabled. The open (AP) or close (CH) button must be pressed continuously to operate the automation. The automation stops when the button is released.
02	Opening takes place in semi-automatic mode, deadman closing operated only by CH command at terminal board; radio control is enabled only if configured to open.
<p>Values 03 and 04 enable deadman activation 'in emergency' which can only be activated by one of the terminal board commands: AP, CH; photocells and sensitive edges are ignored, STOP and shock detection (which does not reverse the movement, but stops the motor) remain managed.</p> <p>During dead man operation, the flashing light makes sequences of 10 fast flashes interspersed with a short pause; movement takes place at minimum speed.</p> <p>If, on the other hand, the automation is activated by radio control or with the terminal board commands PP, PED, OR, the operation remains the standard one (semi-automatic or automatic) with the aid of all enabled safeties.</p> <p>ATTENTION! Only connect a key-operated selector switch installed in the immediate vicinity of the automation to the AP and CH terminals, in order to control it visually: failure to comply with this safety instruction may cause danger to persons or property.</p> <p>To ensure the safety of voluntary start-up, the AP (or CH) terminal board command must be acted upon as follows (see fig. 19, for an example of the opening command):</p> <ul style="list-style-type: none"> - an initial activation (closing of the contact) lasting less than 1 second - release the command and within 1 second reactivate the command and hold it: from this moment on, the automation moves with the operator present, stopping when the command is released. <p>As a further protection function: activation of the CH selector control while it is opening, or of the AP selector control while it is closing, stops the automation; to reactivate it, all the controls must be released and the sequence in fig. 19 repeated.</p>	
03	Enabling of deadman operation 'in emergency for residential installations' , with the terminal board control AP the sash can be fully opened, the terminal board control CH will only be available when the sash is fully open: only when the sash is fully open can it be closed again. During emergency operation '5-É5' is shown on the display (pressing TEST resets the display for a few seconds).
04	Enabling of deadman operation 'in emergency for condominium installations' , which can only be operated with the terminal board control AP; until fully open, without the possibility of closing. It is only possible to open the automation. During emergency operation, the display shows '5-É7' (pressing TEST resets the display for a few seconds).
A8 00	Automation open indicator / photocell test function and "battery saving" / boom light configurations (only for WAY) NOTE: the signal given by the automation open indicator can only be used if the "low power" mode is disabled (L / 00)
00	The indicator is off when the automation is closed, and steadily lit during manoeuvres and when the automation is open.
01	The indicator flashes slowly during opening manoeuvres, and is lit steadily when the automation is completely open. It flashes quickly during closing manoeuvres. If the automation is stopped in an intermediate position, the lamp extinguishes twice every 15 seconds.
02	Set 02 if the output SC is used for the photocell test. See fig. 11-12.
03	Set to 03 if the output SC is used for the "battery saving" function. See fig. 13-14. When the automation is completely open or closed, the controller unit deactivates any accessories connected to terminal SC to reduce battery consumption.
04	Set to 04 if the output SC is used for the "battery saving" function and photocell test function. See fig. 13-14.
05	Only for barrier WAY: boom lights always on.
06	Only for barrier WAY: boom lights on with boom still, flashing with boom in movement.
07	Only for barrier WAY: boom lights briefly flashing with stopped boom, flashing with moving boom
08	Only for barrier WAY: boom lights briefly flashing with closed boom or stopped in intermediate position, flashing with moving boom, off with open boom.
09	Only for barrier WAY: boom lights with short flashing with closed boom or stopped in intermediate position, flashing with moving boom, steady with open boom.
11 04	Setting deceleration during opening and closing
12 04	See chapters 14 and 15
01-05	01= the automation decelerates near the mechanical stop/limit switch ... 05= the automation decelerates long before the mechanical stop/limit switch.

13 05	Setting automation open limit switch constant speed approach distance N.B.: the manoeuvre speed is set with parameter 42. After decelerating, the automation completes the distance to the limit switch at constant speed.
14 05	Setting automation closed limit switch constant speed approach distance N.B.: the manoeuvre speed is set with parameter 42. After decelerating, the automation completes the distance to the limit switch at constant speed.
05-40	For TW90 automations: 05= approx. 15 cm distance; ... 40= approx. 30 cm distance; ... 40= approx. 120 cm distance. For WAY operators: 05= approx. 0.5 degrees rod rotation; ... 40=approx. 4 degrees rod rotation NOTE: - with 4m rod, 4 degrees of rotation is equivalent to a vertical movement of approx. 28 cm - with 5m rod, 4 degrees of rotation is equivalent to a vertical movement of approx. 35 cm
15 50	Partial opening adjustment (%) (only for TW90) N.B.: this parameter is set to 50% (half of total automation travel); by default not displayed for WAY barrier (PED control not managed).
10-99	From 10% to 99% of total automation travel.
16 10	Adjusting automatic closing time after partial opening (only for TW90) The countdown starts when the pedestrian opening is reached, as defined in paragraph 15. NOTE: this parameter is not displayed for WAY automations.
00-90	Pause time settable from 00 to 90 s.
92-99	Pause time settable from 2 to 9 min.
20 00	Type of signaling provided by COR output NOTE: the signal given by the COR output can only be used if the "low power" mode is disabled (L 1 00).
00	STANDARD operation managed by parameter 79
01	Contact closed if the control unit is working properly. Contact open if central locked in alarm.
02	Contact closed if the control unit is powered by the mains or charged battery. Open contact due to a fault: control unit powered by low battery (voltage level set by par. 85) or with error alert B&L 0 (the control unit no longer accept commands).
03	Closed contact if none of the fault related situations 1 and 2 occurs. Open contact if at least one of the fault related situations 1 and 2 occurs.
04	Closed contact if the automation is not completely open. Open contact if the automation is completely open.
05	Closed contact if the automation is not completely closed. Open contact if the automation is completely closed.
21 30	Setting automatic closing time The timer starts from the automation open state and continues for the set time. Once the set time is reached, the automation closes automatically. The timer count restarts if a photocell is triggered.
00-90	Pause time settable from 00 to 90 s.
92-99	Pause time settable from 2 to 9 min.
22 00	Enabling of management for opening with automatic re-closure exclusion If enabled, the exclusion of automatic re-closure only applies for the command selected via the parameter. For example: if you set 220 1, automatic re-closure is excluded following an AP command, but it is activated following a PP or PED command. NOTE: The command has open-stop-close or close-stop-open sequence activation function.
00	Disabled.
01	An AP (opening) command activates the opening manoeuvre. When the automation is fully open, automatic reclosure is excluded. A subsequent AP (open) command activates the closing operation.
02	A PP (step-by-step) command activates the opening manoeuvre. When the automation is fully open, automatic reclosure is excluded. A subsequent PP (step-by-step) command activates the closing operation.
03	A PED (partial opening) command activates the partial opening operation. Automatic reclosure is excluded. A subsequent PED (partial opening) command activates the closing operation. NOTE: for WAY automation, the PED command is not managed.
23 03	Tolerance on opening stop NOTE: parameter are visible if limit switches are disabled on parameter 60 (60 00, TW90 automation) or for WAY automation; adjust the value of par.23 to be less than or equal to that of par.25 (for WAY automations: leave the factory setting).
0 1-05	0 1= minimum tolerance (rotor revolutions) ... 05= maximum tolerance (rotor revolutions)
24 03	Tolerance on closing stop NOTE: parameter are visible if limit switches are disabled on parameter 60 (60 00, TW90 automation) or for WAY automation; adjust the value of par.24 to be less than or equal to that of par.26 (for WAY automations: leave the factory setting).
0 1-05	0 1= minimum tolerance (rotor revolutions) ... 05= maximum tolerance (rotor revolutions)

37 01	Setting motor torque during position recovery Adjust motor torque with parameter 37 if, during position recovery, the values set with parameters 30 and 31 are insufficient to allow the automation to complete the manoeuvre. If position recovery is not completed, normal automation operation will not be resumed.
00	The response of the obstacle detection system depends solely on the values set for parameters 30 and 31.
01	The response of the obstacle detection system depends on the values set for parameters 30 and 31 and on the maximum current value stored during travel acquisition.
02	The response of the obstacle detection system is a 70% reduction in maximum torque for a period of 1 s.
03	The response of the obstacle detection system is a 80% reduction in maximum torque for a period of 2 s.
04	The response of the obstacle detection system is a 100% reduction in maximum torque for a period of 3 s.
05	The response of the obstacle detection system is a 100% reduction in maximum torque for a period of 5 s.
40 05	Setting opening and closing speed
41 05	See chapters 14 and 15
01-05	01= minimum speed, ..., 05=maximum speed TW90/800: min=6 m/min; max=12 m/min TW90/600/HS: min=6 m/min; max=25 m/min TW90/800/R: min=6 m/min; max=18 m/min WAY/004: min=90° in 4"; max=90° in 11" WAY/005: min=90° in 5"; max=90° in 17"
42 03	Setting end of manoeuvre constant approach speed Once deceleration is complete, the automation continues to the limit switch at constant speed. The distance is set with the parameters 13 and 14.
01-05	For TW90/800 and TW90/600/HS: 01= 250 RPM; 02= 300 RPM; 03= 350 RPM; 04= 400 RPM; 05= 450 RPM; 06= 500 RPM; 07= 550 RPM; 08= 600 RPM For TW90/800/R: each value is halved (125 RPM, 150 RPM, ...) For WAY: each value is divided by 10 (25 RPM, 30 RPM, ...) NOTE: The minimum and maximum approaching speeds vary according to the installed motor model. The settings are divided in constant size steps. Indicative values: TW90/800 - TW90/820 from approximately 2 m/min to 5 m/min TW90/600/HS - TW90/620/HS from approximately 3 m/min to 8 m/min TW90/800/R - TW90/820/R from approximately 2 m/min to 6 m/min WAY/004, WAY/005: min=10° in 1"; max=10° in 2.2" NOTE: to adjust the approach to the last 10° of travel, set parameters 13, 14 to value 10
49 01	Setting number of automatic closure attempts after activation of sensing edge or obstacle detection (crush protection)
00	No automatic closure attempts.
01-03	From 1 to 3 automatic closure attempts. We recommend setting a value equal to or lower than the value set for parameter R2. Automatic closure is only performed if the automation is completely open.
50 00	Setting photocell mode during automation opening (FT1)
00	DISABLED. Photocell is not active or not installed.
01	STOP. The automation stops and remains stationary until the next command is received.
02	IMMEDIATE REVERSE. The automation reverses immediately if the photocell is activated during automation opening.
03	TEMPORARY STOP. The automation stops as long as the photocell is obstructed. The automation resumed opening when the photocell is cleared.
04	DELAYED REVERSE. The automation stops if the photocell is obstructed. The automation closes when the photocell is cleared.
51 02	Setting photocell mode during automation closing (FT1)
00	DISABLED. Photocell is not active or not installed.
01	STOP. The automation stops and remains stationary until the next command is received.
02	IMMEDIATE REVERSE. The automation reverses immediately if the photocell is activated during automation closure.
03	TEMPORARY STOP. The automation stops as long as the photocell is obstructed. The automation resumed closing when the photocell is cleared.
04	DELAYED REVERSE. The automation stops if the photocell is obstructed. The automation opens when the photocell is cleared.

52 01	Photocell (FT1) mode with automation closed This parameter is not visible if AB 02, AB 03 or AB 04 is set.		
00	If the photocell is obstructed, the automation cannot open.		
01	The automation opens when an open command is received, even if the photocell is obstructed.		
02	The photocell sends the automation open command when obstructed (usable only if L 100).		
53 00	Setting photocell mode during automation opening (FT2)		
00	DISABLED. Photocell is not active or not installed.		
01	STOP. The automation stops and remains stationary until the next command is received.		
02	IMMEDIATE REVERSE. The automation reverses immediately if the photocell is activated during automation opening.		
03	TEMPORARY STOP. The automation stops as long as the photocell is obstructed. The automation resumed opening when the photocell is cleared.		
04	DELAYED REVERSE. The automation stops if the photocell is obstructed. The automation closes when the photocell is cleared.		
54 00	Setting photocell mode during automation closing (FT2)		
00	DISABLED. Photocell is not active or not installed.		
01	STOP. The automation stops and remains stationary until the next command is received.		
02	IMMEDIATE REVERSE. The automation reverses immediately if the photocell is activated during automation closure.		
03	TEMPORARY STOP. The automation stops as long as the photocell is obstructed. The automation resumed closing when the photocell is cleared.		
04	DELAYED REVERSE. The automation stops if the photocell is obstructed. The automation opens when the photocell is cleared.		
55 01	Photocell (FT2) mode with automation closed This parameter is not visible if AB 02, AB 03 or AB 04 is set.		
00	If the photocell is obstructed, the automation cannot open.		
01	The automation opens when an open command is received, even if the photocell is obstructed.		
02	The photocell sends the automation open command when obstructed.		
56 00	Enable close command 6 s after activation of photocell (FT1-FT2), or instant command This parameter is not visible if AB03 or AB04 is set. NOTE: in the case of photocells being blanked during opening, the 6 seconds count starts when the automation is in the fully open position. If the automation enters stand-by in the fully open position, the function is not managed (the photocells are not powered).		
00	Disabled.		
01	Enabled. When the photocell barrier FT1 is crossed, a close command is sent 6 seconds later.		
02	Enabled. When the photocell barrier FT2 is crossed, a close command is sent 6 seconds later.		
03	Enabled. With the gate fully open, crossing the FT1 photocells instantly triggers a closing command.		
04	Enabled. With the gate fully open, crossing the FT2 photocells instantly triggers a closing command.		
57 00	Selecting contact type (NC or 8.2 kOhm) on inputs FT1/FT2/ST In conformity with the safety regulations EN12453-EN12445, devices using an 8.2 kOhm contact instead of an NC contact may be connected to inputs FT1/FT2/ST. The controller unit must therefore be configured accordingly.		
	FT1	FT2	ST
00	The controller is configured for NC contacts by default.		
01	8k2	N.C.	N.C.
02	N.C.	8k2	N.C.
03	8k2	8k2	N.C.
10	N.C.	N.C.	8k2
11	8k2	N.C.	8k2
12	N.C.	8k2	8k2
13	8k2	8k2	8k2

60 00	Limit switch enabling (only for TW90) NOTE: parameter visible only for TW90 automations.
00	Limit switches disabled; programming the stroke and repositioning causes the sash to press on the mechanical stops, par. 25 and 26 adjust the stopping distance from these.
01	Limit switches enabled; stroke programming and repositioning are managed by the activation of the magnetic opening and closing limit switches.
65 05	Setting motor stop distance
01-05	01= faster deceleration/shorter stop distance ... 05= slower deceleration/longer stop distance.
71 01	Selecting installation position of motor relative to automation (seen from interior side) N.B.: in the event of a reset to restore the default parameters, this parameter must be set again manually.
00	Motor installed on left.
01	Motor installed on right.
73 00	Configuring sensing edge COS1 NOTE: not visible for WAY automations, input COS1 disabled.
00	Sensing edge NOT INSTALLED.
01	NC contact (normally closed). The automation reverses only when opening.
02	Contact with 8k2 resistor. The automation reverses only when opening.
03	NC contact (normally closed). The automation always reverses.
04	Contact with 8k2 resistor. The automation always reverses.
12	Management of two 8k2 sensitive edges connected in parallel (total resistance 4k1). The automation reverses only when opening.
14	Management of two 8k2 sensitive edges connected in parallel (total resistance 4k1). The automation always reverses.
74 00	Configuring sensing edge COS2 NOTE: for WAY automations, the selectable values are only 00, 01, 02; the sensitive edge acts only if it intervenes during closing, causing complete opening.
00	Sensing edge NOT INSTALLED.
01	NC contact (normally closed). The automation reverses only when closing.
02	Contact with 8k2 resistor. The automation reverses only when closing.
03	NC contact (normally closed). The automation always reverses.
04	Contact with 8k2 resistor. The automation always reverses.
12	Management of two 8k2 sensitive edges connected in parallel (total resistance 4k1). The automation reverses only when closing.
14	Management of two 8k2 sensitive edges connected in parallel (total resistance 4k1). The automation always reverses.
76 00	Configuring radio channel 1 (PR1) N.B.: With ROGER TECHNOLOGY plug-in radio receiver board.
77 01	Configuring radio channel 2 (PR2) N.B.: With ROGER TECHNOLOGY plug-in radio receiver board.
00	STEP MODE.
01	PARTIAL OPENING
02	OPENING
03	CLOSING.
04	STOP.
05	Courtesy light. The output COR is managed from the remote control. The light remains lit as long as the remote control is active. The parameter 79 is ignored.
06	Courtesy light in step mode (PP). The output COR is managed from the remote control. The remote control turns the courtesy light on and off. The parameter 79 is ignored.
07	STEP MODE with confirmation for safety. ⁽¹⁾
08	PARTIAL OPENING with confirmation for safety. ⁽¹⁾
09	OPENING with confirmation for safety. ⁽¹⁾
10	CLOSURE with confirmation for safety. ⁽¹⁾

78 00	Configuring flashing light frequency
00	The frequency is set electronically from the flashing light unit.
01	Slow flash.
02	Light flashes slowly when automation opens, rapidly when automation closes.
79 60	Selecting courtesy light mode
00	Disabled.
01	PULSE. The courtesy light illuminates briefly at the start of each manoeuvre.
02	ACTIVE. The light remains lit for the entire duration of the manoeuvre.
03-90	From 3 to 90 s. The light remains lit for the time period set after the manoeuvre is completed.
92-99	From 2 to 9 minutes. The light remains lit for the time period set after the manoeuvre is completed.
80 00	Clock contact configuration/Enable GAPT mode (only for TW90) When the clock function is active, the automation opens and remains open. At the end of the programmed time set with the external device (clock), the automation closes.
00	When the clock function is active, the automation opens and remains open. Any command signal received is ignored.
01	When the clock function is active, the automation opens and remains open. Any command signal received is accepted. When the automation returns to the completely open position, the clock function is reactivated.
<p>It is possible to connect an external clock/timer to the PED input to activate the GAPT (Temporary Partial Opening Management), which works as follows:</p> <ul style="list-style-type: none"> • when the PED contact closes, a partial opening is performed; when the contact is released, the door closes • if an AP command is received when the door is in the partial opening position, the automation opens completely, and when it closes again, it returns to the partial opening position • if a CH command is received when in the partial opening position, even with the PED contact closed, it closes completely; if an AP command is then received, after opening completely, GAPT operation is reactivated • if the PED contact is open, the automation returns to standard operation (the closing command always closes completely) • with GAPT mode enabled, the ORO input is not managed • values 02, 03, 04 are not available for WAY automations (PED input not enabled) • values 03, 04 prevent dead man mode (par.87) 	
02	With GAPT mode enabled, the control unit does not accept AP and CH commands
03	With GAPT mode enabled, the control unit only accepts AP commands
04	With GAPT mode enabled, the control unit accepts AP and CH commands
81 00	Enable safeguarded automation closure/opening Enabling this parameter ensures that the automation is not left open due to an incorrect and/or accidental command. This function is NOT enabled if: <ul style="list-style-type: none"> • the automation receives a STOP command; • the sensitive edge intervenes, detecting an obstacle in the same direction in which the function is enabled. If instead the sensitive edge detects an obstacle during the movement opposite to the one guaranteed, the function remains active. • the number of closure attempts set by parameter R2 has been reached; • the acquired position is lost (perform position recovery, see chapter 21).
00	Disabled. The parameter B2 is not displayed.
01	Enabled. After a period of time set with parameter B2, the control unit signals a 5 second warning with the flashing light, regardless of the parameter R5, and then closes the automation.
02	Enabled. If the automation is closed as a result of a step mode command, after a period of time set with parameter B2, the control unit signals a 5 second warning with the flashing light (regardless of the parameter R5), and then the automation closes. If the automation is stopped by the obstacle detection system during a closure manoeuvre, the automation closes after a period of time set with parameter B2. If the automation is stopped by the obstacle detection system during an opening manoeuvre, the automation closes after a period of time set with parameter B2.
82 03	Setting safeguarded closure/opening activation time N.B.: this parameter is not visible if the value of parameter B1 = 00.
02-90	Wait time settable from 2 to 90 s.
92-99	Wait time settable from 2 to 9 min.

85 03	Selection of the battery operation management Setting a value different than 00 a battery voltage level check is activated. The desired operation type can be selected via parameter 85 and an error alert can be activated through the COR output via parameter 20.
00	The control unit always accepts commands until the battery is completely exhausted.
01	The command becomes active when the battery voltage drops to the minimum threshold (22V _{min} with B71/BC charger; 24.6V _{min} with B71/PBX external charger)
02	The command becomes active when the battery voltage drops to the medium threshold (23V _{min} with B71/BC charger; 25V _{min} with B71/PBX external charger)
03	The command becomes active when the battery voltage drops to the maximum threshold (24V _{min} with B71/BC charger; 25.4V _{min} with B71/PBX external charger)
86 00	Selecting the battery operation limitations N.B.: the parameter is visible only if par. 85 is different than 00
00	There is no limitation for the commands when the battery voltage drops under the selected threshold. An error alert may be activated via the COR output (if parameters 85 and 20 are adequately set).
01	When the battery voltage drops under the threshold selected with par. 85, for more than 30 seconds, the control unit accepts only opening commands and does not perform closing.
02	When the battery voltage drops to the threshold selected in param. 85, for more than 30 seconds, the control unit, after a 5-second pre-flashing, automatically opens the system and accepts only a closing command.
03	When the battery voltage drops under the threshold selected with par. 85, for more than 30 seconds, accepts only closing commands even if the DRO input is active and if the parameter is 80 0 1.
04	When the battery voltage drops to the threshold selected in param. 85, for more than 30 seconds, the control unit, after a 5-second pre-flashing, automatically closes the automation and accepts only a opening command.
05	If the mains power supply is lost for 30 seconds, an opening command is triggered; after a 5-second pre-flashing, the automation remains open and does not accept any commands until the mains power supply is restored.
87 00	Selection of the battery type and consumption reduction
00	Battery 24V _{min} (2x12V _{min}) with B71/BCHP. Acceleration/deceleration/speed reduction enabled, to increase the battery life.
01	Battery 24V _{min} (2x12V _{min}) with external battery charger B71/PBX. Acceleration/deceleration/speed reduction enabled, to increase the battery life.
02	Battery 24V _{min} (2x12V _{min}) with external battery charger B71/PBX. No performance reduction, maximum battery consumption.
03	Battery 24V _{min} (2x12V _{min}) with external charger B71/PBX. No reduction in performance. Maximum battery consumption
L0 00	Enabling serial communication NOTE: if par. A 1 is set to 02 or 03 (TW90 High Speed or reversible), even if par. L0 is saved in memory with the value 00, B74/BCONNECT is always enabled (checking par. L0 displays 0 1).
00	Disabled
01	Enabling module B74/BCONNECT
02	Enabling debug board (internal use)
L1 04	Configuration of 'low power stand-by' mode (only for TW90/800, TW90/820) NOTE: 'low power stand-by' is activated after inactivity that lasts for the preset time, i.e. with the automation stopped and no activation of commands or keys on the display. With the automation fully open and paused for automatic reclosing, stand-by is not activated, as it is in any case an active phase of automatic operation (regulated by par. A2 and 2 1). Similarly, the time countdown for guaranteed closing/opening (par. B 1 and B2) is considered an active phase, so stand-by is not activated. ATTENTION! This parameter is not displayed for TW90 High Speed and Reversible automations, or for WAY automations.
00	'low power' mode disabled
01	Stand-by activation after 5 minutes of inactivity
02	Stand-by activation after 10 minutes of inactivity
03	Stand-by activation after 15 minutes of inactivity
04	Stand-by activation after 20 minutes of inactivity
FA 00	Restoring factory default values NOTE. This procedure is only possible if a password has NOT been set to protect the data; if one is stored, it must first be unlocked by entering the values P 1, P2, P3, P4 (confirmed by the display showing CP 00).
	Warning! Restoring default settings cancels all settings made previously except for parameter A 1, 60, 7 1, 85, 87, L0, L 1: after restore, check that all parameters are suitable for the installation. • Press the PLUS + and MINUS - button. • The display flashes after 4 s rE5- • The default factory settings have now been restored.
Note: it is possible to reset the parameters in a second way: when the control unit is switched on, before the firmware version appears on the display, press and hold down the ▲ (UP ARROW) and ▼ (DOWN ARROW) buttons for 4s.	

In the event of a power failure or electric fault you can manually release the gate and to enable you to be able to open and close the gate by hand.

In order to do this you must first make sure the power has been isolated, then you need to gain access to the control cabinet using the keys supplied and pull the release handle as shown below.

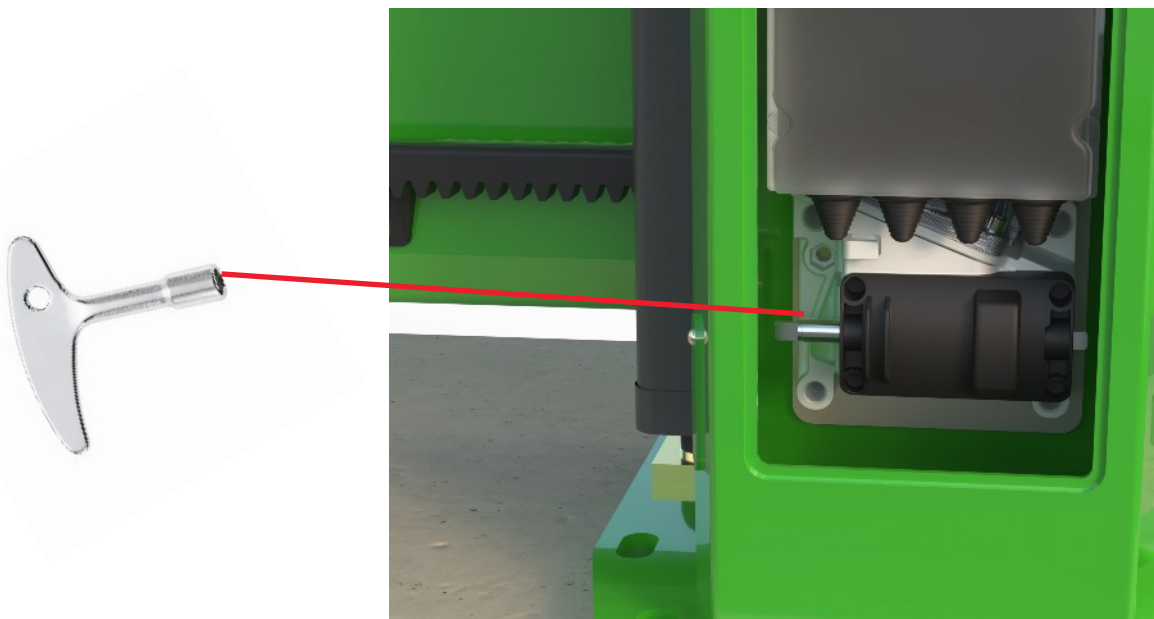

Place the release key supplied
on to the shaft to the side of the gearbox
as shown above.

Then turn anti-clockwise to release
the gearbox which will allow the gate to
free wheel. Then turn the handle
clockwise to tighten to put the gate
back into automatic.

Make sure you have control of the gate whilst it is in free wheel, the gates are designed to free wheel very easily and can be operated by one person however great care should be taken to ensure no damage is caused when pushing the gate in manual mode. Once you are done turn the red handle lock the motor back in to normal mode.

Note, When powering the gate back up and putting back into use it is advisable to do this when the gate is in the fully opened position so that it knows where it is for its first operation.

Caution - The supplier will take no responsibility for any damaged that is caused by misuse of manually using the gate.



As stated at the beginning of this manual we recommend a bi-annual service, but at a bare minimum, it is imperative that you get a service done once every 12 months. This is not a sales tactic in disguise, there is a very serious health and safety issue/risk associated with not complying to this. Also in order for your gate to keep complying with the appropriate legislation.

Before carrying out any maintenance to the installation, disconnect the mains power supply.

Make sure you have disconnected/isolated the power before attempting any work.

A Maintenance Contract should be sought from a specialist company after a maximum of 5000 manoeuvres or 1year from the install date.

Occasionally clean the photocell optical components and make sure they are free from dirt, water, rain, soil etc.. ? Batteries in photo cells may need to be changed every 6 months or sooner dependant on use. The gate will not work properly without photo cell function.

Have a qualified technician (installer) check the correct setting of the electric clutch.

If the power supply cable is damaged, it must be replaced by the manufacturer or its technical assistance service, or else by a suitably qualified person, in order to prevent any risk.

When any operational malfunction is found, and not resolved, disconnect the mains power supply and request the assistance of a qualified technician (installer). When automation is out of order, activate the manual release to allow the opening and closing operations to be carried out manually.

Gearbox drive unit is "sealed" for life and requires no further lubrication.

Parts that require lubrication -

The gate has a drive rack that needs lubricated with a DW40 type lubricant.

On a annual service these items mentioned above should be lubricated as well as all other checks listed below.

Checks on a service - All safety edges are operational

All photocells are operational

Limit switched are set correct

Gates are structurally ok e.g no damage

All connections/wiring are ok

All push buttons and stop circuits operate correctly



This Manual **must** be completed in accordance with the guidelines below, **at any point** service/repair work is carried out on the product. This is to achieve two things;

1. To keep a history of the product for yourself and your supplier/manufacturer.
2. To keep an accurate log of any historical or recent modifications, and/or problems, to help an engineer in the event of any future work required on the product.
3. This page is continued on the next page if extra space is needed.

Date	Reason for visit/Action taken	Engineers Signature
/ /20		
/ /20		
/ /20		
/ /20		
/ /20		
/ /20		
/ /20		
/ /20		
/ /20		
/ /20		
/ /20		
/ /20		
/ /20		
/ /20		
/ /20		
/ /20		
/ /20		
/ /20		
/ /20		

Commissioning Certificate



We certify that the system covered by this certificate has been commissioned satisfactorily.			
Site Name		Completion	
Site Reference		Engineers Installing	
Installation Commenced	/ /	Commissioning	
Equipment Fitted			
Handover Date			

Part 2. Existing Installation Items not covered under warranty/ This certificate:

Part 3. Certificate Signing off

Installers Name		Signature	
On Behalf of		Date of Signing	
Address		Position	
Client Name		Signature	
On Behalf of		Date of Signing	
Site Address		Position	

Part 4. Onsite training for product usage

Trainers Name,	Date	Competency / Job Title	Signature
Attendees Name	Date	Signature to confirm understanding	

Declaration of Conformity

In accordance with BS EN ISO/IEC 17050-1:2010

We: Ultimation Direct Ltd

Of: Trent Lane, Maltkiln lane, Newark, Notts NG24 1HN In

accordance with the following directives:-

Supply of Machinery (Safety) Regulations 2008

Electromagnetic Compatibility Regulations 2016

The Radio Equipment Regulations 2017

Hereby declare that:

Equipment: Automated Sliding Gate

Model no: D5400

Are in conformity with the applicable requirements of the following documents:

Supply of Machinery (Safety) Regulations 2008.

BS EN 12453:2017+A1:2021 Industrial, commercial and garage doors and gates—Safety in use of power operated doors— Requirements.

BS EN 12604:2017 Industrial, commercial and garage doors and gates—Mechanical aspects—Requirements and test methods.

BS EN 13241:2003+A2:2016 Industrial, commercial and garage doors and gates - Product standard. Products without fire resistance or smoke control characteristics.

BS-EN12978:2003 Industrial, commercial and garage doors and gates. Safety devices for power operated doors and gates. Requirements and test methods.

BS EN 13856-2:2013 Safety of machinery. Pressure sensitive protective devices. General principles for the design and testing of pressure sensitive edges and pressure sensitive bars.

I hereby declare that the equipment named above has been designed to comply with the relevant sections of the above referenced specifications. The unit complies with all applicable Essential Requirements of the Regulations.

Signed:



Name: Matthew Mulholland

Position: Technical Director

Place: Newark

Date: March 2026

Specification

Maximum Gate Length: 6.0 metres (depending on height)
 Maximum Gate height: 2.4 metres
 Power Requirement: 230v, Single Phase, 50Hz, 6 Amps
 Drive Motor: 24v motor & wormed gearbox
 Opening/Closing time: 20 seconds (variable)
 Duty Cycle: 100% continuous duty rating
 Finish: Oxy primed and powder coated

Control: Roger technology B70

Motor/Gearbox

Power :- 0.55 kw
 Voltage :- 24v single phase
 Max Weight :- 600 Kg
 Power :- 540 N
 Speed :- 25 M/Min (0.42M/S)
 Gearing :- Mod 4

Dimensions



Made in the UK

