

*O&M Manual*  
*Revision 3.0*



## **D8400 Rising Curb**

Max Span 5m, Lifts 340mm, 500mm, 800mm,  
Max Axle weight 12 tonnes  
100 % Duty cycle

1. Inductions and Warnings	Page 03
2. Delivery, Movement and Transport	Page 04
3. Lifting and Handling	Page 05
4. Layout/Description	Page 06
5. Civil's installation guide	Page 07 - 08
6. Installation Guide	Page 09 - 11
7. Cabinet layout	Page 12 - 14
8. Control Panel Layout	Page 15
9. Connection terminals	Page 16
10. Using the controller	Page 17
11. Setting the curbs parameters	Page 18
12. Setting the timers	Page 19
13. Setting the speeds	Page 20
14. Setting the time and date	Page 21
15. Alarms and History	Page 22
16. Lower time clock	Page 23
17. Manual release	Page 24
18. Setting the limits	Page 25
19. Interlocking	Page 26
20. Maintenance	Page 27
21. Trouble shooting	Page 28
22. Commissioning Certificate	Page 29
23. Service log	Page 30
24. Deceleration of conformity	Page 31
25. Technical Data	Page 32

This equipment is part of a large range of traffic flow products. They are designed to be easy to install, as all settings and internal wiring have been completed in our factory. Any of the instructions in this manual should only be carried out by a qualified service engineer or a competent person.

The Rising Curbs are ready to be installed, connected to a single phase power supply and have any pre-cut loops wired into them (Please note that loop detectors are sold separately). The steps must be completed before the power is turned on to prevent accidents.

The following information is a guide only, and whilst we have made every effort to be accurate and correct there may be printing errors which we cannot be held responsible for.

With a correct installation you can expect to enjoy many years of reliable service from this product, we do however recommend that the product has a bi-annual service carried out by a qualified engineer. Please contact our service department to obtain a quote. As we manufacture the products we are best suited to

## Important Safety Notice



Automatic Rising Curbs are designed to Control the flow of vehicular traffic only. It can be dangerous to allow the passage of pedestrians and any other self-powered animal or device to utilise this method of access without appropriate warnings and or signage.

It may be necessary for the end user of this product to provide an alternative, safe method of access to cater for the previously mentioned categories.

The end user should fit all necessary signage and warning notices to either side of the gate, which should be visible and clear from all directions of approach.

The product that was shipped to you was designed with a control program to protect all categories from harm or affect this however is only a safety precaution and should not be modified or tampered with by any unauthorised person not sanctioned by the manufacturer. Please sign and date below to say that you have read and

understood this notice before ANY installation work:

/     /20

The "Warnings" leaflet and "Instruction booklet" supplied with this product should be read carefully as they provide important information about safety, installation, use and maintenance.

Scrap packing materials (plastic, cardboard, polystyrene etc) according to the provisions set out by current standards. Keep nylon or polystyrene bags out of children's reach.

Keep the instructions together with the technical brochure for future reference.

This product was exclusively designed and manufactured for the use specified in the present documentation. Any other use not specified in this documentation could damage the product and be dangerous.

The Company declines all responsibility for any consequences resulting from improper use of the product, or use which is different from that expected and specified in the present documentation.

Do not install the product in explosive atmosphere.

The construction components of this product must comply with all applicable regulations and subsequent amendments. As for all non-EEC countries, the above mentioned standards as well as the current national standards should be respected in order to achieve a good safety level.

## Information on using this manual



- ✍ Read all information thoroughly
- ✍ Pay attention to all safety advice
- ✍ Be aware of the symbols (shown above right and above left) as they have different meanings. One is an information symbol, the other a warning.
- ✍ There are many artists impressions of the product in this manual you should refer to the images as a guide only. **Professional CAD** drawings should be used as a reference drawing and nothing else. As before every effort has been made to be 100% accurate in this manual but we cannot make any guarantees.
- ✍ As we constantly innovate our products we may change the quoted spec and any other details that have been documented in this manual so you should always refer to the supplier to see if the manual that was shipped with your product is the latest edition.
- ✍ As with all electrical installations you should use a qualified electrician and obey all of the latest laws and regulations.
- ✍ Be sure to fill out and complete **ALL** paperwork where instructed as this manual is the equipments log book and maintenance manual.

The Company declines all responsibility for any consequences resulting from failure to observe Good Technical Practice when constructing closing structures (door, gates etc.), as well as from any deformation which might occur during use.

The installation must comply with the provisions set out by the applicable regulations and subsequent amendments.

Disconnect the electrical power supply before carrying out any work on the installation. Also disconnect any buffer batteries, if fitted.

Fit an omnipolar or magnetothermal switch on the mains power supply, having a contact opening distance equal to or greater than 3mm.

Check that a differential switch with a 0.03A threshold is fitted just before the power supply mains.

Check that earthing is carried out correctly: connect all metal parts for closure (doors, gates etc.) and all system components provided with an earth terminal.

Fit all the safety devices (photocells, electric edges etc.) which are needed to protect the area from any danger caused by squashing, conveying and shearing, according to and in compliance with the applicable directives and technical standards.

This article describes how your equipment will be delivered to you, specifications on the transportation used and advice including health & safety on movement of the equipment.



The manufacturer will use a qualified transport company to deliver the product conforming to the necessary regulations as detailed below:

- ✘ All drivers are qualified
- ✘ All drivers are tested once yearly ( If applicable )
- ✘ All drivers carry risk assessments and method statements (available on request)
- ✘ They are controlled under law to conform as there are no trade regulation standards to comply with

Health and safety Considerations:

Moving Goods Safely (MGS) is a national project involving both the Health and Safety Executive (HSE) and Local Authorities (LA) working in partnership. The project aims to reduce injuries and ill-health arising from the movement of goods from supplier through haulier to the recipient and end user including any home deliveries. The project will focus upon the delivery and collection of goods and the hazards this generates. It covers the main areas that cause the majority of injuries and ill-health to workers, including:

- ✘ Workplace transport;
- ✘ Slips & trips, and;
- ✘ Musculoskeletal disorders (MSD).

The movement of goods presents us, as health and safety regulators, with the challenge of dealing with a huge variety of issues. The commercial organisations involved within the movement of goods are diverse including haulier, third party logistics providers, pallet networks, retailers etc, with some very large companies, thousands of small businesses and the self-employed. The movement of goods is more than just trucks on the road with a large proportion of accidents happening at the delivery/collection sites that are often not directly under the control of the company making the delivery or collection. Communication and cooperation problems can arise due to the many organizations involved in the movement of the goods, and this can also lead to difficulties in effectively managing health and safety.

(Source H&S Executive UK 2008)

The gates should ALWAYS! be moved with care and attention. The products are very heavy individually as well as a whole. You should not attempt to move this or any other products by unapproved handling methods.

**WARNING**

---

Always take safety precautions when lifting and handling heavy objects, in accordance with Manual Handling Operation Regulations 2022.

Always wear correct safety equipment in the vicinity of equipment being off loaded. The gate is to be steadied by means of ropes attached to each end of the gate; preventing it from swinging whilst being manoeuvred. It is important to use the correct nylon slings with a SWL of 2 tonnes for each sling.

---

**HANDLING**

Due to the size and weight of our D8400 Rising Curbs, the services of a mobile crane/ hiab are essential for safe off-loading and positioning. Due to the design and build of our Rising Curbs the unit will arrive completely built in two pieces for your convenience the Curb itself and the control cabinet. The strapping points we would recommend would be around the Curb itself underneath the top plates at either end to allow a steady lift and ease of alignment onto ducting's and foundations. The correct install procedure can be found in the following pages.



Shown below is a general layout of a typical D8400 Rising Curb

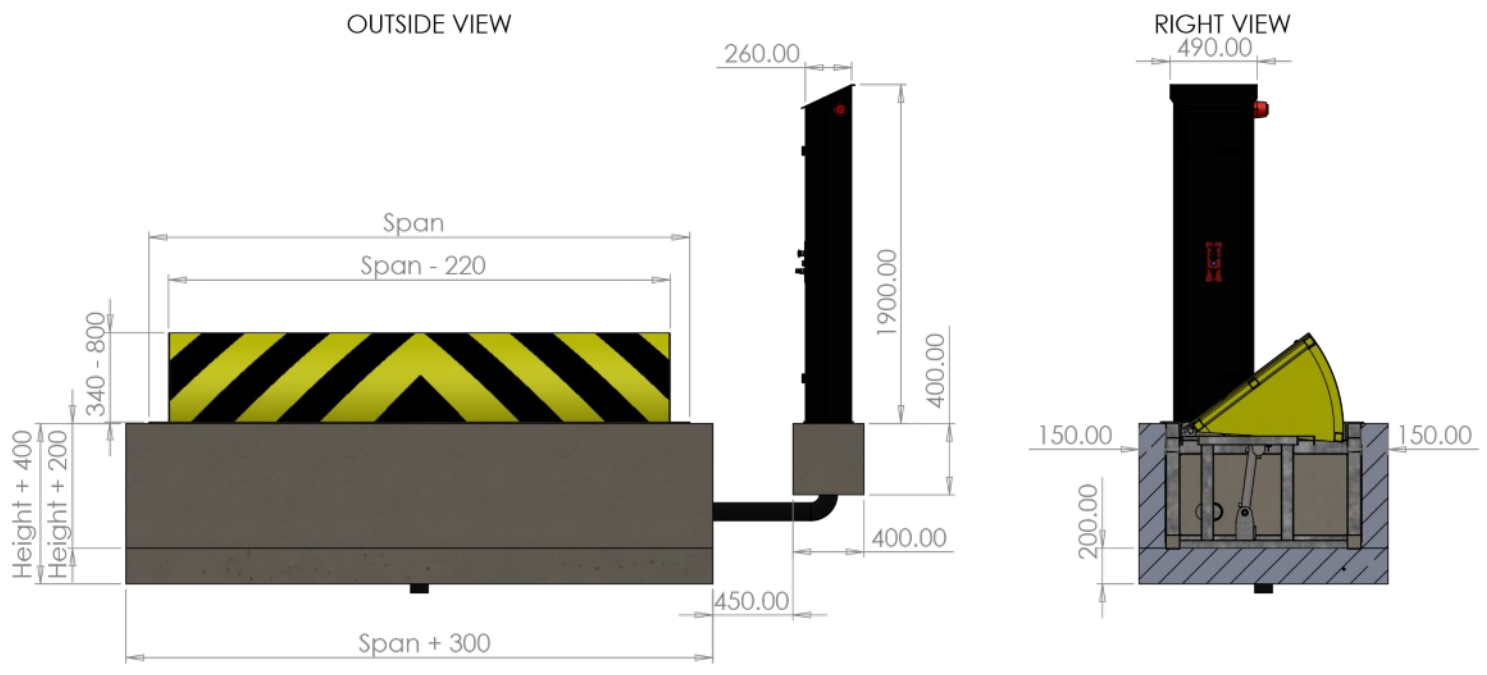

**General Description,**

The D8400 Rising Curbs are designed to provide the perfect solution for security in Industrial locations where Reliability and Security is paramount. Commonly chosen for applications such as car parks, prison entrances corporate access and transport service yards, they provide an aesthetically pleasing, high security entrance control solution. They are fitted with our reliable heavy duty drive systems which are almost silent in operation and are fitted within the gate trough. They have an Impeccable service record with maximum longevity in the most demanding Environments. Rising Curbs are engineered to allow bolt down fixing on the control Cabinet to suitable concrete pads, and are compatible with all current access controls.





## Foundations

All foundations should be installed as per drawing supplied as hole size's will vary depending on the size of the Curbs. (Contact your supplier if you have not been issued one.) All foundations should be installed 10 x days prior to the gates being installed.

If details of the base have not been specified, we recommend a concrete mix to BS EN 206:2013+A2:2021 "Concrete specification, Performance, Production and Conformity" to type C35, which is equally suitable for external and internal environments.

The foundation must be positioned accurately and installed to the correct levels to ensure successful installation.



Careful consideration should be made when deciding the location of the Curb to avoid Underground obstructions such as power cables , services, pipework and drainage. Please note the Curb will require adequate drainage installed.

---

## Ducting

Ducting carrying cables for power and control should enter the Cabinet from underground. Two ducts are normally required, one for the power supply, the other for the control. Where the power supply and control cables are to come from a common place; a single duct can be used.

These ducts must be sited accurately in the base as shown on the contract drawing. The use of cable access pits is recommended where there may be a number of ducts used entering the gate or long cable runs are necessary. We also recommend the ducts used be of 100mm diameter PVC. Alternative types and sizes may be acceptable, subject to discussions with your equipment supplier.

Slow bends should always be used wherever possible, and the inclusion of draw ropes throughout the ducting system, will ensure that the cables are easily installed.



Please Note General install for civil's will be done in 2 stages; Firstly the hole will be excavated for the Curb itself to be installed along with the ducting between Curb and cabinet, Also the cabinet base will be poured at this point. These will then require the specified setting times before the curb is lowered into place. A general layout is included above however the specified drawing provided with each product must be used each time.



The Rising Curb can be lowered into place once the foundations have properly cured, Recommendation would be to lower these onto a dry mix to allow the Curb to be moved once in place whilst the camber and slope of the road are adhered to, The cables and hoses should be pulled through the ducting into the cabinet base at this point also.

Now that the Curb and hoses are in place the gap around the Curb and foundations can be back filled which will finish the civil's part of the install allowing the engineer to finish the install once the concrete has set to its full potential.

**Rising Curb Bits Box;**

**Please check your fixings prior to install to ensure smooth running of your installation**

1. 4 x m16 x 180mm Through Bolts
2. 4 x m16 Caps
3. Cabinet Keys
4. O & M Manual
5. Key switch keys

Please note loop detectors and ancillary products are sold separately and should be ordered at the time of quotation for your convenience.

**Step 1, installing the cabinet**

The Control cabinet can be lowered into place guiding the hoses and cable into the provided access beneath the Cabinet. The control cabinet has been designed for aesthetics as well as ease of install, note the four fixing holes around the base will need to be at least 50mm from the edge of the concrete pad.

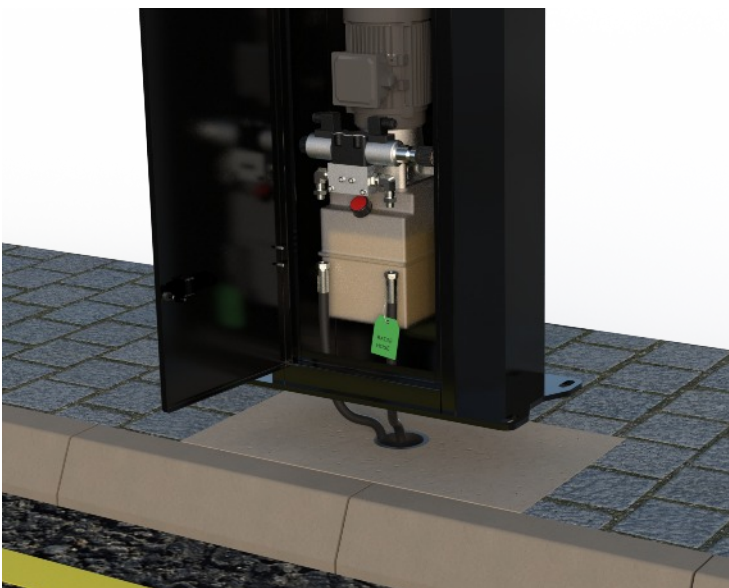

### Step 2, Fixing the cabinet

Now the cabinet is lowered the four fixing holes can be drilled using an m16 sds bit.

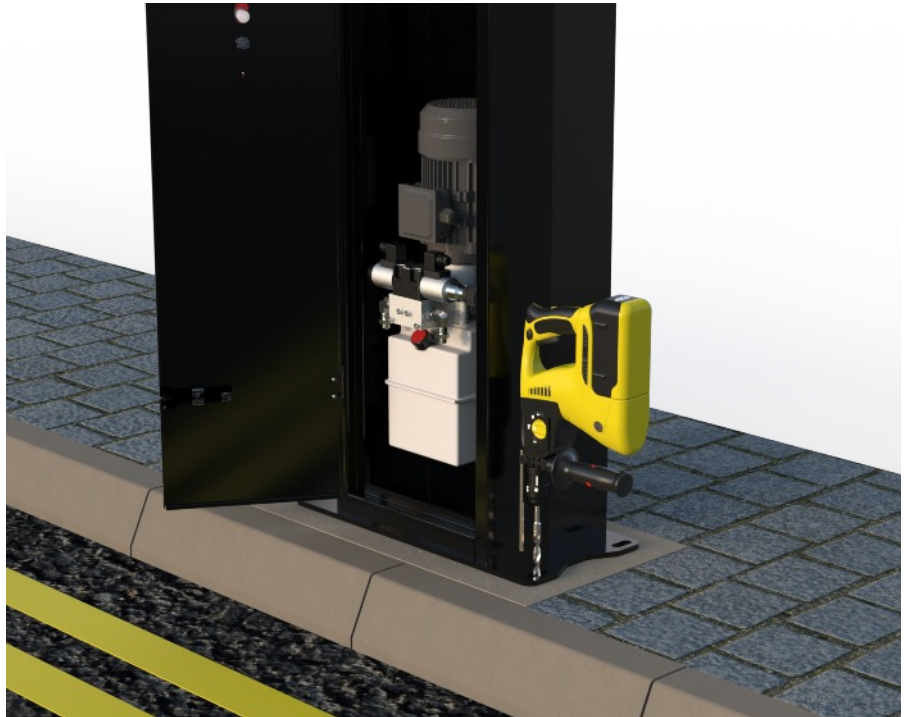

### Step 3, Fixing the cabinet

The provided m16b anchor bolts can be now inserted into the drilled 16mm holes, note the use of a suitable hammer will be required at this point.

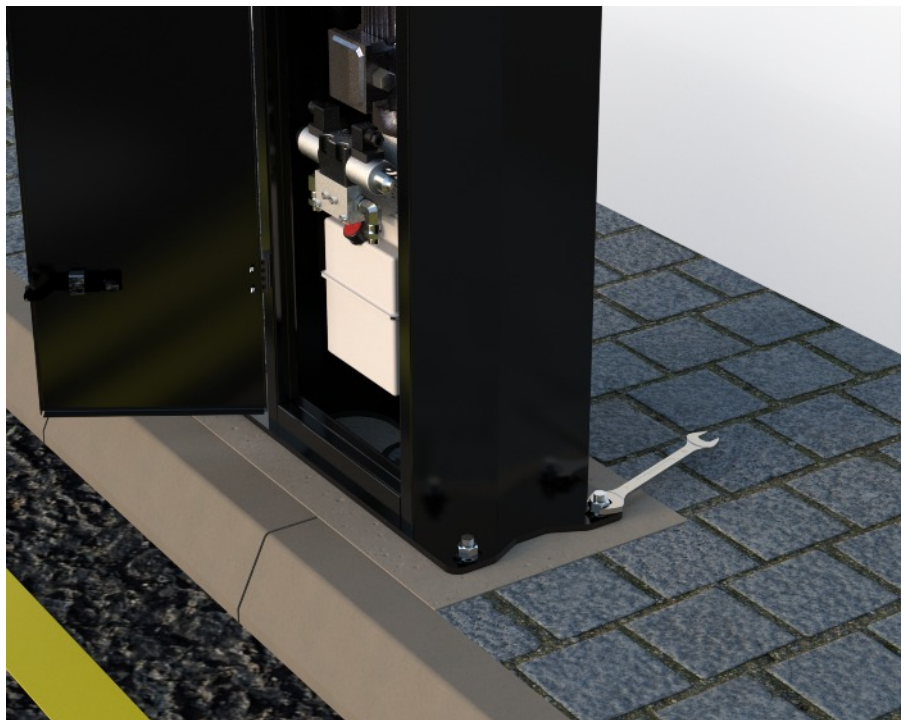

### Step 4, Fixing the cabinet

With your anchor bolts now in place the nuts can be tightened to secure your cabinet in place, once any levelling required has been completed, The use of a 22mm spanner or suitable socket will be required at this point.

**Step 5, Connecting the hoses**

The hoses can be connected to the pump unit and tightened with a suitable 22mm spanner (please note the raise is on the right hand side this will be tagged for your convenience)



**Step 6, Connecting the limits**

The limit four core cable can now be connected to the green terminal blocks in the cabinet. This will comprise of +24v dc, -24v dc and 2 x switch input wires which are +2

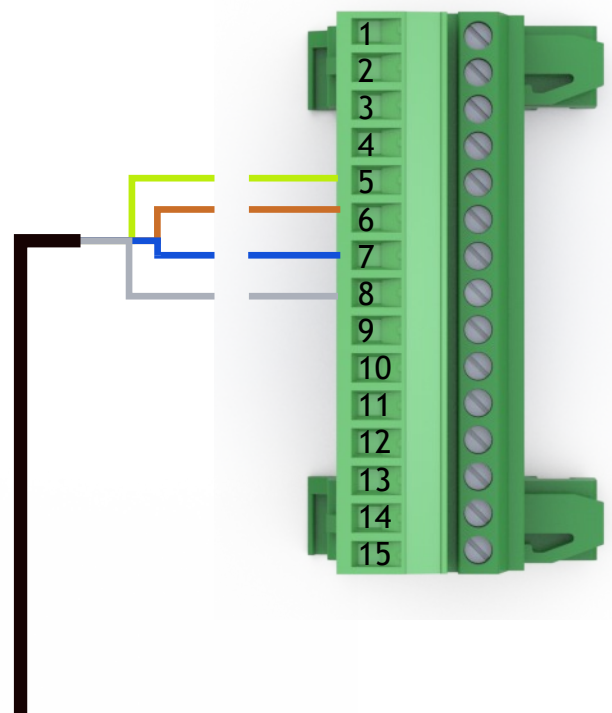

**Mains Installation,**

Now the gate is fully installed the mains can be connected to the mains rotary isolator. The access controls can be wired directly into the terminal rail following the terminal list on the next page.

**Control Cabinet**

Connect the mains into the three phase rotary isolator found in the trough under the panel. This is a 230v single phase 6amp supply required.

**Pre set-up checks**

Now your Curb is fully powered and connected it is a good idea to raise and lower the product to ensure correct oil levels / speed and operation before adjusting settings. Please note the recommended oil level when the Curb is in the lowered position. This will fall and raise as the curb operates but should not fall below this level when the curb is in the lower position.

As a note the pressure can be adjusted via the pressure valve under the red cover located to the left top of the oil reservoir, this is altered using a 3mm Alan key, whilst this has already been preset in our factory the valve will need setting more in motor change applications.

**3 Phase Motor**

**Manual Release Valve**

**Oil Reservoir,  
Advised level  
When Lowered**



## The Cabinets front panel explained,

The front cabinet has three main functions details of which are explained bellow.

1. Emergency Stop Button
2. Fault Warning Light
3. Raise / Lower Key switch

### 2. Fault Warning light

This is an indication of what is wrong with the curb should a fault affect the curbs operation this will help identify and source the problem for your convenience and time. The following flash code can be seen.

4 - flashes indicates a break in the stop circuit.

5 - flashes indicates a limit switch fault, both limits will be in at the same time.

6 - Flashes indicates a safety fault, The curbs will not raise when a safety fault is detected.



### 1. Emergency Stop

This is pre wired for convenience to stop the curb still should you need to lock it in place or stop suddenly in the case of an emergency. Simply pressing the button in will stop the curb in the position that it is in, To release simply twist the button and it will pop forward allowing continued use of the curb.

### 3. Raise/Lower Key switch

This is installed for convenience of use for a direct raise and lower point local to the curb, simply turn the provided key to either raise or lower your curb depending on the required need.



The Cabinet comes equipped with a pre wired beacon sounder / flashing light, this will activate once the blocker is in motion as it raises and lowers, The dip switches located on the back of the sounder can be used to turn the sound on and off should you prefer the flash only option, There are also 4 x volume adjustment settings to get the correct volume for your site application, in addition to this the central switches can be used to change the siren tone to adjust to sites requirements.

Traffic Lights can be added as an extra to your cabinet and fitted in our workshop if ordered with the product at quotation stage, These are 24v red and green lights and will illuminate red whilst the Curb is raised or moving and green only when the Curb is fully lowered, This can also be delayed via a timer if required. These are highly recommended as a visual aid for drivers to prevent over eager access into site and a true indication of the Curbs position t all times.

3.5 amp PSU

PLC Control

3 Phase Inverter

2 amp 24v fuse

Lower Relay

6 amp 230v Breaker

Traffic Light Relay

Raise Relay





Safety Loop Detectors



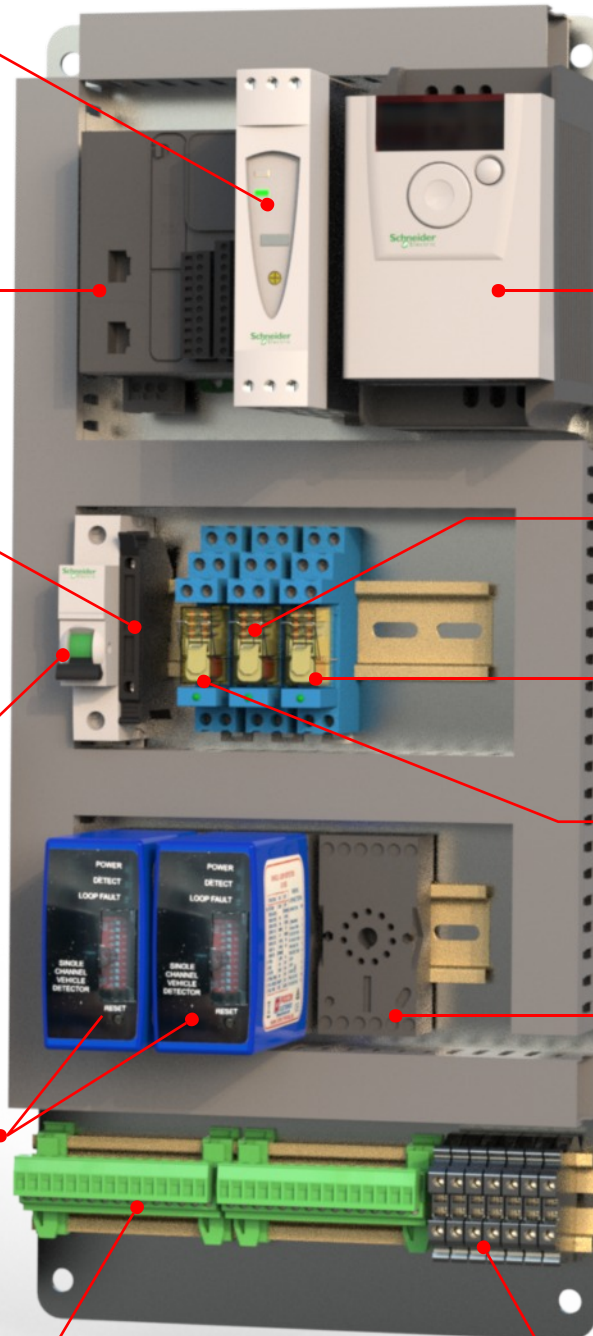





















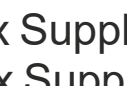







Free Exit Loop

Terminal Blocks

Motor Connections



-  U - Motor
-  V - Motor
-  W - Motor
-  Earth to motor

-  1) Common 24VDC
-  2) Stop N/C
-  3) Lower N/O
-  4) Raise N/O
-  5) Common 24VDC
-  6) Lower Prox switch N/O
-  7) Raise Prox switch N/O
-  8) - 24VDC
-  9) + 24VDC 
-  10) - 24VDC 
-  11) + 24VDC 
-  12) - 24VDC 
-  13) + 24VDC Aux Supply
-  14) - 24VDC Aux Supply
-  15) Red Traffic light + 24VDC
-  16) Green Traffic light +24vdc
-  17) Safety loop 1
-  18) Safety loop 1
-  19) Safety loop 2
-  20) Safety loop 2
-  21) Barrier terminal 1 - Common
-  22) Barrier terminal 2 - Stop
-  23) Barrier terminal 3 - Safety
-  24) Barrier terminal 5 - Raise
-  25) Barrier terminal 6 - Lower
-  26) Barrier terminal 16 - Kerb lowered
-  27) Barrier terminal 17 - Barrier Lowered
-  28) Barrier terminal 18 - Barrier Lowered
-  29) Barrier terminal 19 - Barrier Raised
-  30) Barrier terminal 20 - Barrier Raised

Inputs -

- I0 - Barrier lowered
- I1 - Stop
- I2 - Lower
- I3 - Raise
- I4 - Lower limit
- I5 - Raise limit
- I6 - Safety 1
- I7 - Safety 2

Outputs -

- Q0 - Inverter Run
- Q1 - Lower Valve
- Q2 - Raise Valve
- Q3 - Traffic light
- Q4 - Kerb Lowered
- Q5 - Barrier Safety
- Q6 - Barrier Raise
- Q7 - Barrier Lower

Barrier inputs

Kerb inputs

# Using the Controller Display

D8400

The Curbs PLC has a remote controller display screen where you can change features and operate the gate. The Display is located in the station cabinet.

To operate the display you simply use the arrows on the scroll pad to navigate your way through the screen. There is an ESC key which will take you back to the previous screen or the home key which will return you to the home screen.



D8400 Main Menu			
Parameters			
Time Clocks			
Timers			
Drive Settings			
Motor Settings			
Select	Alarm	Lower	Raise

The home screen is as shown on the left. It is the main screen that appears once power up. You will see keys R3 and R4 are labelled up on screen as an open and close which you can use to operate the curb. On this screen you can access all of the gates options such as adjustable parameters, timers, timeclocks and drive settings so you can fine tune your curb settings specifically to sites requirements.



# Setting The Curb Parameters

D8400

The Curbs PLC has various parameters that can be set so you can alter the way the gate operates.

To change the parameters you will need access to the PLC graphic display located in the gate cabinet, once you have access to this follow the below instructions.

D8400 Main Menu			
Parameters			
Time Clocks			
Timers			
Drive Settings			
Motor Settings			
Select	Alarm	Lower	Raise

Using the Arrows/dial navigate the cursor over the parameters menu and press the ok button.

Parameters		
No Pass Timer OFF		
Safety Reverse ON		
Loop/Photocell Close ON		
Barrier Interlock OFF		
Top Up Programme ON		
ON	OFF	Alarm

You can now scroll through the parameters and choose what you would like to turn on. To turn on/off use the R1/R2 key which is labelled on the screen in the bottom left corner.





<i>Parameters</i>	<i>Operation</i>
No Passage Timer	Allows curb to auto close after set time
Safety Reverse	Reverses curb on safety activation
Loop/photocell close	Raises curb after cell activation
Barrier Interlock	Turns on interlock function
Top Up Programme	Boosts the pump should the Curb fall from its raise limit
N/O safety	For use on older gates with N/O safety
Lower Time clock	Enables the lower time clock
Warning Light	Turns on warning light output

Within the Curbs plc screen you can set up various timers, and delays to signals and accessories.

## Accessing Timers

D8400 Main Menu			
Parameters			
Time Clocks			
Timers			
Drive Settings			
Motor Settings			
Select	Alarm	Lower	Raise

To access the timers scroll down To Timers and press ok, here you will see a list of timers that you can alter to suit your requirements



Kurb Timers			
No Pass delay			
Raise delay timer			
Raise Override			
Lower Override			
Lower Valve delay			
Select	Alarm		

Once you are in the Curb timers screen you can now select the timer you wish to change.



<b>Timer</b>	<b>Operation</b>
Lower Valve Delay	Delays the Lower valve from opening on a lower command to the Curb
Raise delay Timer	Delays the curb from raising once given a raise signal from photocells/ Push Button or access controls.
No pass delay	When turned on in parameters this timer raises the curb if no raise signals are given when the curb is in the lower position.
Raise Override	This timer sets the Length of time the motor runs in the raise incase the raise limit has an issue
Lower Override	This timer sets the Length of time the motor runs for in the lower incase the lower limit has an issue

Within the PLC's graphic display you are able to set the speeds Of the drive to enable you to fine tune the gate to exactly how You want it.

D8400 Main Menu			
Parameters			
Time Clocks			
Timers			
Slow down settings			
Drive Settings			
Select	Alarm	Lower	Raise

To access the drives settings scroll To drive settings in the main gate Menu.



Drive configuration			
Acceleration			
Deceleration			
Normal speed			
Slow down speed			
Slow down ramp			
Select	Alarm		

Once you are in drive configuration You will see the various speed Settings you can adjust. See the table Below for settings.

<b>Speed/setting</b>	<b>Operation</b>	<b>Default</b>
Acceleration	This is the time taken to accelerate Up to normal speed	30 ( 3.0 secs )
Deceleration	This is the time taken to decelerate To a stop once the limit contact is in	10 ( 1.0secs )
Normal speed	This is the final speed that the curb runs	50hz ( 75hz Max )

# Setting The Time And Date

D8400

The Curb has a built in clock which requires setting once installation is complete. This will enable functions such as the use of the 24 hour time clock and correct functions of the alarm history. This can be set in the following way.

D8400 Main Menu			
Slow Down			
Drive Settings			
Motor Settings			
Cycle Counter			
Controller Setup			
Select	Alarm	Lower	Raise

To set the time and date please scroll down to controller setup and select



Setup Menu			
Controller info			
Controller setup			
Display Setup			
Controller State			
Controller Status			
Select	Alarm		Back

Then select controller setup again

Controller Setup			
Date and Time			
Serial 2			
Select	Alarm		Back

Then select Date and Time



Date and Time			
4 / 2 / 2012			
19 : 45 : 51			
Apply			Cancel

The Date and Time can now be set using the control pad of the schnieder screen. Please note this will automatically change during summer / winter clock alterations

Now the date and time has been set this enables the use of the 24 hour time clocks. Built in to the programme we have a Lower time clock and auto loop time clock. Details of which can be found on the following page. The date and time set will also allow an easier detection of faults and help with fault finding and rectification. Specifically times and dates when faults are recorded.

D5600 Main Menu			
Parameters			
Time Clock Configuration			
Timers			
Slow Down Settings			
Drive Settings			
Select	Alarm	Lower	Raise

The alarm history can be accessed from the main menu by pressing the alarm button.



Alarm View			
Stop Circuit Broken			
Safety Latched 1 min			
History	R2	R3	Back

The first screen accessed shows all recently recorded faults. Please note that if faults are active the screen back ground will change to a red colour indicating that there is an active fault. All inactive faults can be cleared using the F2 key on the controller.

Alarm History			
Stop Circuit Broken			
Safety Latched 5 min			
Alarm	Delete		Back

The full fault history can be accessed using the history button. This will show all faults plus dates and times when the faults have been recorded enabling the engineer to get a better understanding of recurring faults.

The Curb has a built in 24hr time clock that can hold the Curb open for set times of the day.

To set the time clock you will need to access the programming Display located in the curbs cabinet. Once you have access to this

Follow the below instructions to set up the Timeclock.



D8400 Main Menu			
Parameters			
Time Clocks			
Timers			
Drive Settings			
Motor Settings			
Select	Alarm	Close	Open

Using the Arrows/dial navigate the Cursor to operator interface and Press ok and you will see the screen As shown to the left. Now enter into Time clocks.

Lower Timeclock			
Lower Time Clock			
Select	Alarm		

There are two Time Clocks Available In the Rising Curb program which is The Open Time clock that holds the curb open and the auto loop time Clock which turns off the auto loop.

Open Timeclock			
Period 1 : Time set			
Period 1 : Day set			
Period 2 : Time set			
Period 2 : Day set			
Period 3 : Time set			
Select	Alarm		

To Set one of the time clocks you must Set at least one period. Each period represents an ON/OFF Time, You can now enter up to 4 periods and set the times and days you require.

Period 1			
On Time		0900	
Off Time		1700	
In Range		0	
Select	Alarm		

When you select a “period time set” it will Take you to the on/off time for that Period, you can now set the times you Need the curb to stay open. In Range Just lets you know if that period is on Or off ( off being 0 )

Period 1			
Monday ON			
Wednesday OFF			
Thursday OFF			
Friday OFF			
ON	OFF		

When you select a “period day set” it will Take you to the on/off screen to set which Days you would like that period to work Using the the on/off buttons which are Indicated at the bottom left hand of the Screen.

**Note, If you are using the time clock feature you must make sure you have set the clock in controller setup.**

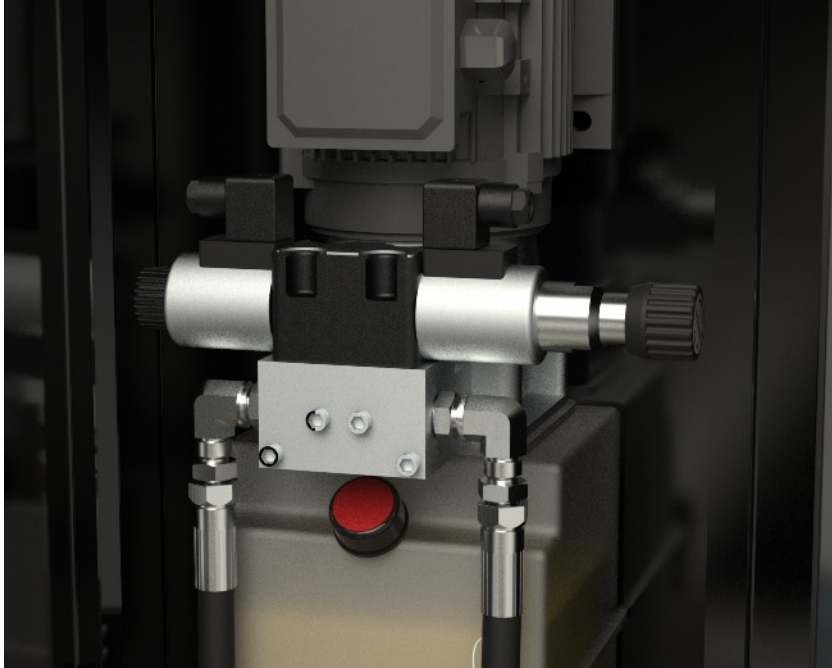

In the event of a failure and the curb be stuck in the raise position please open the cabinet using the provided keys and locate the manual lower valve to the right hand side of the pump unit as shown in the figure. In normal run this will be wound all the way out to allow solenoid operation of the spiral valve.

The valve can be wound in towards the unit itself to allow the flow of oil to return to the tank and the curb will start to lower under its own weight, Please note once the issue has been located and rectified this valve will need returning to its original position to allow the Curb to raise and lower as it should under normal operation. It is also advised to isolate the mains via the rotary isolator before the Curb is manually used.

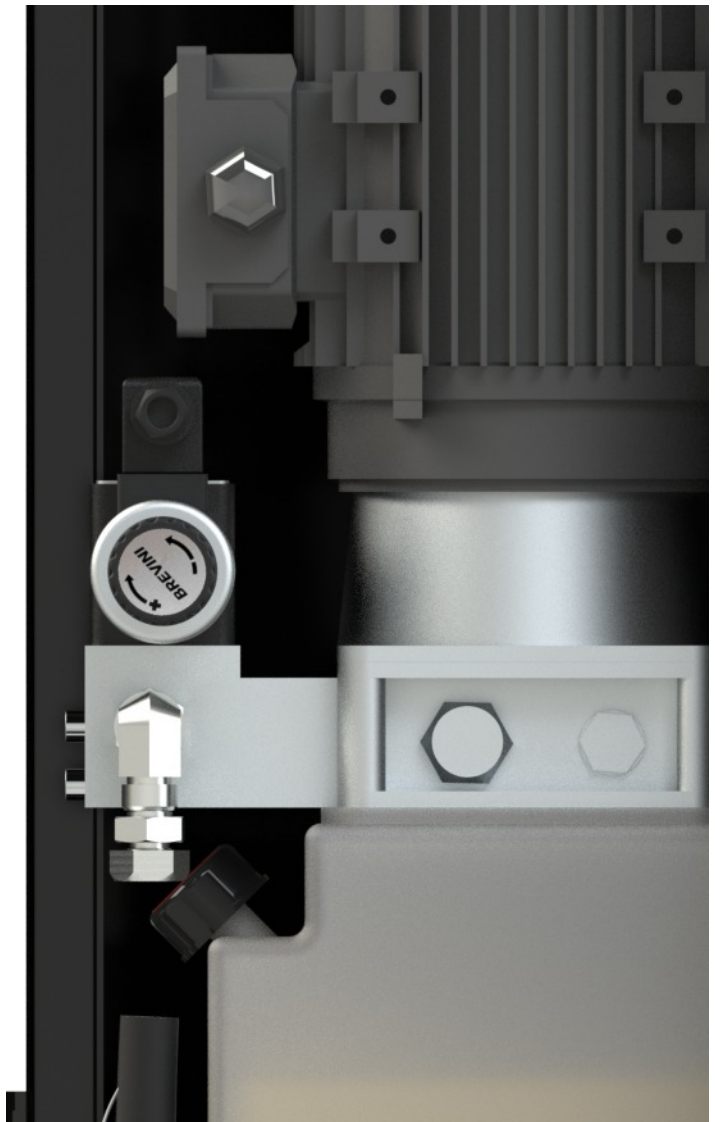

### Step 1,

To adjust the limits you will first need to remove the cover plates from the curb, this can be done by removing the m10 bolts with a 17mm spanner or suitable socket

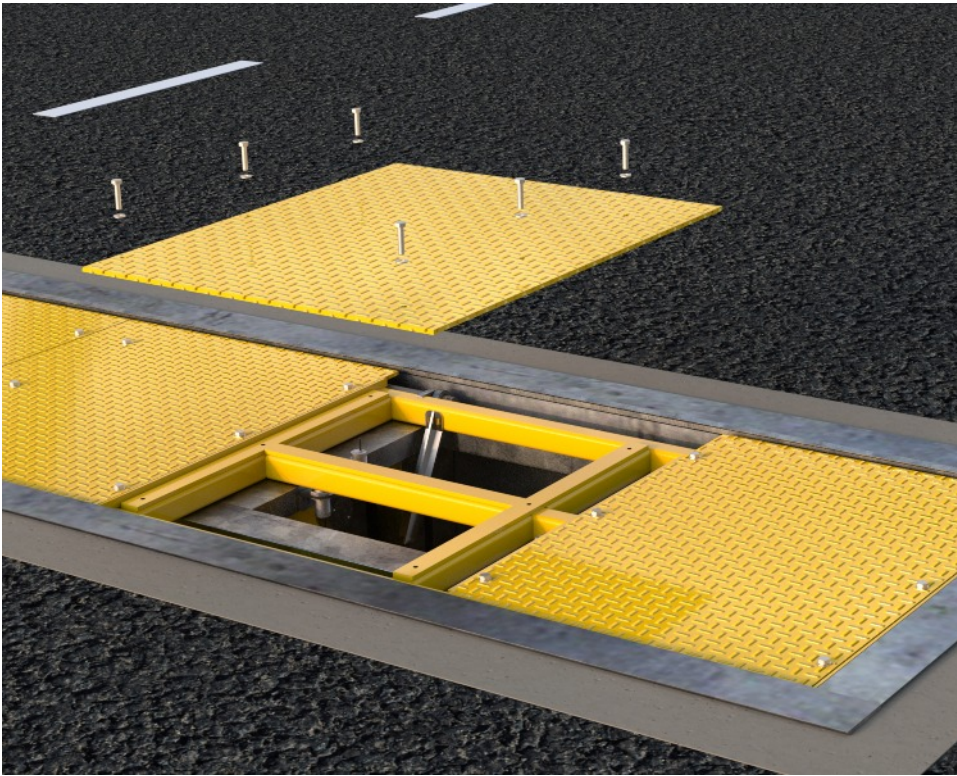

### Step 2,

With the bolts removed The 2 x internal cover plates can be lifted, (please use extreme caution as these plates can be very heavy). Store the limit plates somewhere safe so as not to damage them.

### Step 3,

The limits can be located at the top of the curbs frame, to adjust use a 36mm spanner or suitable grips to loosen the retaining nuts and adjust the limit up or down as required. Once happy the cover plates can be re-installed using steps 1 and 2 in reverse.

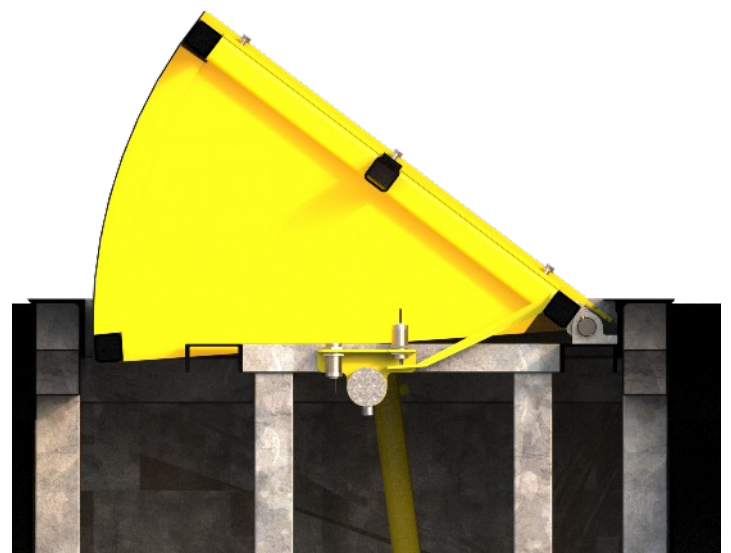
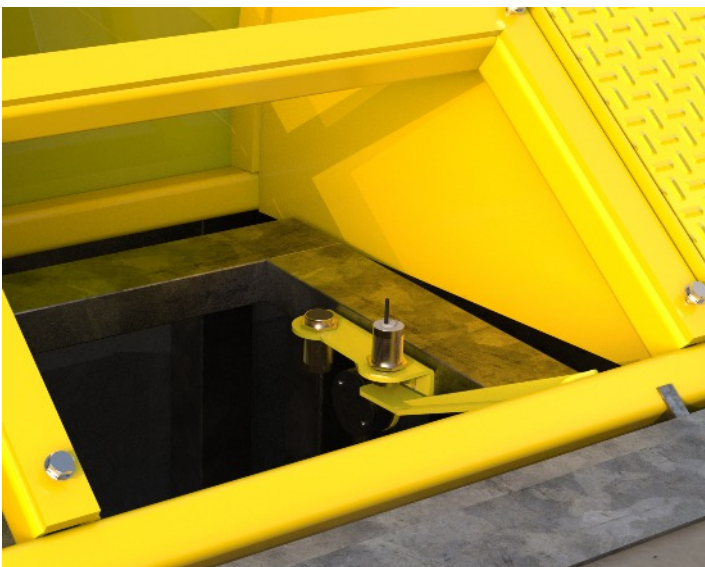

The Curb comes with a built in interlock programme should you need to install this product to work with an external barrier for example, The interlock function will need to be enabled in the parameters section of the green control screen, Details of the interlock wiring are as follows.

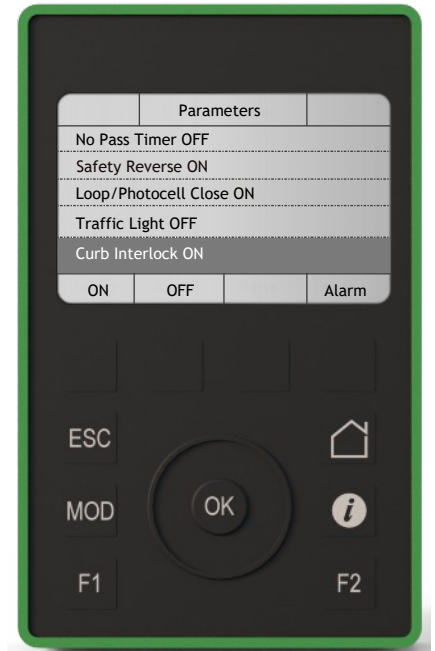

The curb will need a signal from the external product when you wish the curb to raise. This is done by wiring directly into input 1 of the blocker PLC. This however will be voltage conscious and must have voltage coming from the Curb and back to complete the circuit

Plc Output Block

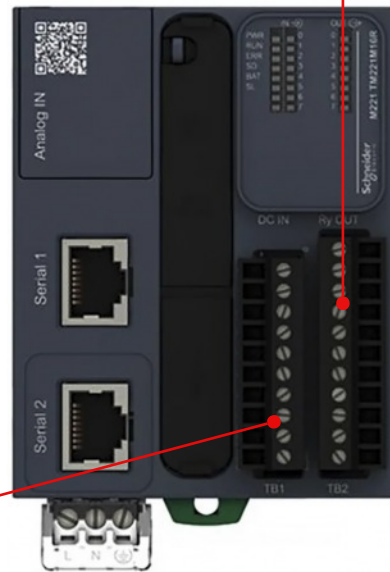

PLC Input Block

You can then wire directly from the plc output block to the terminal rail of the slave product. Our plc gives the voltage back that is fed through the common therefore it can be made to switch positive or negative 24v dc depending on the product. Below is an example of the interlock connections used for our sliding gates. Figure 19.

**Curb Plc**

- Plc Outputs
- Q.4 Curb Lowered
- Q.5 Safety Signal
- Q.6 Open Output
- Q.7 Close Output
- Com 2. Voltage Input

**Terminal Rail**

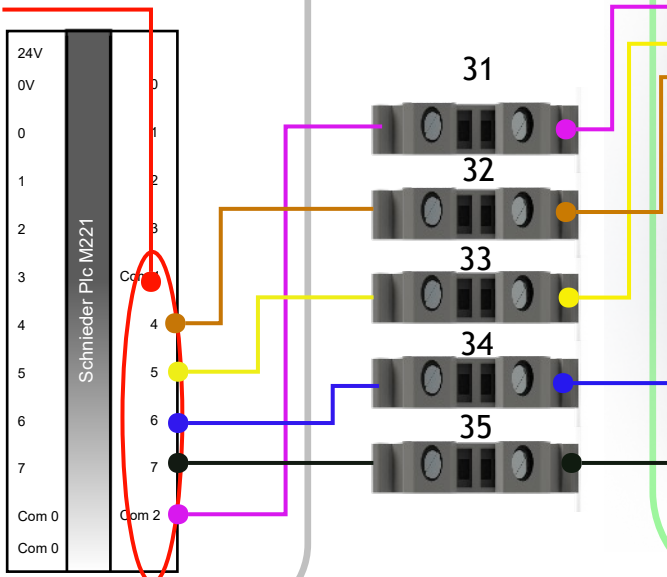

**Slave Product Example**

Terminal rail connections

- 1. Common 24v -
- 2. Common 24v +
- 3. Photocell N/C
- 4. Common 24v +
- 5. Stop N/C
- 6. Common 24v+
- 7. Open N/O
- 8. Common 24v +
- 9. Close N/O
- 10. Common 24v +
- 11. Open Edge 8k2
- 12. Close Edge 8k2
- 13. Common 24v +
- 14. Open Prox N/C
- 15. Close Prox N/C



As stated at the beginning of this manual we recommend a bi-annual service, but at a bare minimum, it is imperative that you get a service done once every 12 months. This is not a sales tactic in disguise, there is a very serious health and safety issue/risk associated with not complying to this. Also in order for your gate to keep complying with the appropriate legislation.

Before carrying out any maintenance to the installation, disconnect the mains power supply.

Make sure you have disconnected/isolated the power before attempting any work.

A Maintenance Contract should be sought from a specialist company after a maximum of 5000 manoeuvres or 1year from the install date.

Occasionally clean the photocell optical components and make sure they are free from dirt, water, rain, soil etc.. ? Batteries in photo cells may need to be changed every 6 months or sooner dependant on use. The gate will not work properly without photo cell function.

Have a qualified technician (installer) check the correct operational settings

If the power supply cable is damaged, it must be replaced by the manufacturer or its technical assistance service, or else by a suitably qualified person, in order to prevent any risk.

When any operational malfunction is found, and not resolved, disconnect the mains power supply and request the assistance of a qualified technician (installer). When automation is out of order, activate the manual release to allow the opening operation to be carried out manually.

Rising Curb drive units are not sealed and therefore require oil levels checking and maintaining as running without sufficient oil can damage the pump unit.

On a annual service these items mentioned above should be lubricated as well as all other checks listed below.

- Checks on a service -
- The release valve is operational
  - All photocells are operational
  - Limit prox switches are set correctly
  - Rising Curb is structurally ok e.g no damage
  - All connections/wiring are ok
  - All push buttons and stop circuits operate correctly
  - Hinge points aren't worn
  - Oil levels are ok
  - Hoses and connections show no signs of leaking
  - Water levels inside the blocker/ Drainage is sufficient

The table (bottom) relates to the diagram directly below to help you trouble shoot electrical component errors

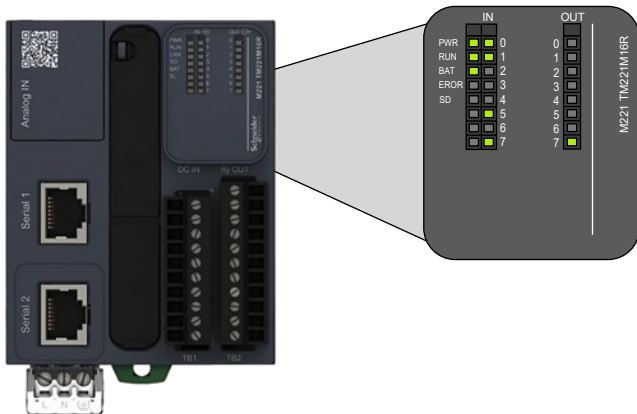

The image on the left shows the input and output LED indicators, use these with the chart below To identify any faults with the curb.

Note, the PLC is located in the gate cabinet.

1. Inputs			
Input	Polarity	Connected to	Operation when active
I0	Normally Closed	External Product closed	If used input tells programme that external product is closed
I1	Normally Closed	Stop circuit	Curb stops if activated and wont run while activated
I2	Normally Open	Lower signal	Lowers Curb
I3	Normally Open	Raise signal	Raises Curb
I4	Normally Open	Lower limit switch	Curb has reached its fully Lowered position
I5	Normally Open	Raise limit switch	Curb has reached its fully Raised position
I6	Normally Closed	Safety loop Detector 1	Curb stops and returns the the lower position until clear.
I7	Normally closed	Safety loop Detector 2	Curb stops and returns the the lower position until clear.
Outputs			
Output:	Polarity:	Connected to:	Operation when active:
Q0	Normally Open	Fault Warning Light	Flashes in pulses depending on fault
Q1	Normally Open	Lower Valve	Activates Relay to open Lower Solenoid
Q2	Normally Open	Raise Valve	Activates Relay to open Raise Solenoid
Q3	Normally Open	Traffic Light Output	Activates Relay to Trigger Traffic Light Change
Q4	Normally Open	Curb Lowered	Active When Interlock is ON
Q5	Normally Closed	Safety Output	Active When Interlock is ON
Q6	Normally Open	Open Output	Active When Interlock is ON
Q7	Normally Open	Close Output	Active When Interlock is ON

# Commissioning Certificate

We certify that the system covered by this certificate has been commissioned satisfactorily.			
Site Name		Completion	
Site Reference		Engineers Installing	
Installation Commenced	/ /	Commissioning	
Equipment Fitted			
Handover Date			

Part 2. Existing Installation Items not covered under warranty/ This certificate:			

### Part 3. Certificate Signing off

Installers Name		Signature	
On Behalf of		Date of Signing	
Address		Position	
Client Name		Signature	
On Behalf of		Date of Signing	
Site Address		Position	

### Part 4. Onsite training for product usage

Trainers Name,	Date	Competency / Job Title	Signature
Attendees Name	Date	Signature to confirm understanding	



This Manual **must** be completed in accordance with the guidelines below, **at any point** service/repair work is carried out on the product. This is to achieve two things;

1. To keep a history of the product for yourself and your supplier/manufacturer.
2. To keep an accurate log of any historical or recent modifications, and/or problems, to help an engineer in the event of any future work required on the product.
3. This page is continued on the next page if extra space is needed.

Date	Reason for visit/Action taken	Engineers Signature
/ /20		
/ /20		
/ /20		
/ /20		
/ /20		
/ /20		
/ /20		
/ /20		
/ /20		
/ /20		
/ /20		
/ /20		
/ /20		
/ /20		
/ /20		
/ /20		
/ /20		

## Declaration of Conformity

In accordance with BS EN ISO/IEC 17050-1:2010

**We:** Ultimation Direct Ltd

**Of:** Trent Lane, Maltkiln lane, Newark, Notts NG24 1HN In

accordance with the following directives:-

Supply of Machinery (Safety) Regulations 2008

Electromagnetic Compatibility Regulations 2016

The Radio Equipment Regulations 2017

Hereby declare that:

**Equipment:** Automated Rising Kerb

**Model no:** D8400

Are in conformity with the applicable requirements of the following documents:

Supply of Machinery (Safety) Regulations 2008.

BS EN 12453:2017+A1:2021 Industrial, commercial and garage doors and gates—Safety in use of power operated doors— Requirements.

BS EN 12604:2017 Industrial, commercial and garage doors and gates—Mechanical aspects—Requirements and test methods.

BS EN 13241:2003+A2:2016 Industrial, commercial and garage doors and gates - Product standard. Products without fire resistance or smoke control characteristics.

BS-EN12978:2003 Industrial, commercial and garage doors and gates. Safety devices for power operated doors and gates. Requirements and test methods.

BS EN 13856-2:2013 Safety of machinery. Pressure sensitive protective devices. General principles for the design and testing of pressure sensitive edges and pressure sensitive bars.

I hereby declare that the equipment named above has been designed to comply with the relevant sections of the above referenced specifications. The unit complies with all applicable Essential Requirements of the Regulations.

Signed:

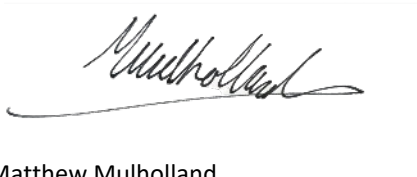

Name: Matthew Mulholland

Position: Technical Director

Place: Newark

Date: March 2026

**Specification**

**Maximum Gate Length:** 5.0 metres  
**Power Requirement:** 230v, Single Phase, 50Hz, 6 Amps  
**Drive Motor:** 3 Phase motor  
**Opening/Closing time:** 8 - 10 seconds (variable)  
**Duty Cycle:** 100% continuous duty rating  
**Finish:** Oxy primed and painted in selimix direct

**Control:** Push-button Open and close - Photocell/safety edges for safety. Dead man keyswitch on the Control panel

**Motor/gearbox**

Combined Worm=PAM NMRV/NMRV Power / 040/075 / Ratio (i1xi2)=750(25x30)  
 Input Dim.=Ø105x14 (IEC 71 B14) / Connection (Worm Wheel-PAM)=Ø18-Ø19  
 Hollow Output Shaft Dim.=Ø28 / Execution=PS2 / Mounting Position=U / Output Cover=Standard  
 Pos.J / Ral 5010/Ral 5010 Blue  
 \*\*\* Motor \*\*\* Three-Phase / 071 / 4 / 0,37-0,45 kW / S1 / Standard Efficiency  
 Regulations=CE / 230/400-265/460 V / 50-60 Hz / Insulation Rating=F / IP56  
 Thermal Protectors=3x Thermistors PTC 130°C / Self-Ventilated / Ral 5010 Blue  
 Terminal Box=Pos.4 / Supplier=Motovario  
 \*\*\* Features \*\*\* VI-Lubrication=Eni Telium VSF 320  
 VI-2nd Red. Lubrication=Eni Telium VSF 320



**Made in the UK**

