

D650

# AUTOMATIC SLIDING GATE



OM MANUAL



1. Inductions and warnings	Page 03
2. Delivery, Movement and transport	Page 04
3. General layout	Page 05 - 06
4. Installation	Page 07 - 11
5. Control Panel Layout	Page 12 - 15
6. Connection Diagrams	Page 16 - 17
7. Front Panel Layout / Usage	Page 18
8. Initial Set-up Walk Through	Page 19 - 20
9. Initial Parameters	Page 21
10. Positions Explained	Page 22
11. Auto Close Explained	Page 23
12. Input Configuration	Page 24
13. Loop Settings	Page 25
14. Manual Release	Page 26
15. Error Codes	Page 27
16. Trouble Shooting	Page 28 - 29
17. Maintenance	Page 30 - 31
18. Parts List	Page 32
19. Service Log	Page 33
20. Commissioning Certificate	Page 34
21. Declaration Of Incorporation	Page 35
22. Technical Data	Page 36

This equipment is part of a large range of traffic flow products. They are designed to be easy to install, as all settings and internal wiring have been completed in our factory. Any of the instructions in this manual should only be carried out by a qualified service engineer or a competent person.

The Gates are ready to bolt down, connect to a single phase power supply and have any pre-cut loops wired into them (Please note that loop detectors are sold separately). The steps must be completed before the power is turned on to prevent accidents.

The following information is a guide only, and whilst we have made every effort to be accurate and correct there may be printing errors which we cannot be held responsible for.

With a correct installation you can expect to enjoy many years of reliable service from this product, we do however recommend that the product has a bi-annual service carried out by a qualified engineer. Please contact our service department to obtain a quote. As we manufacture the products we are best suited to care for your equipment.

### Important Safety Notice



Automatic gates are designed to Control the flow of vehicular traffic only. It can be dangerous to allow the passage of pedestrians and any other self-powered animal or device to utilise this method of access without appropriate warnings and or signage.

It may be necessary for the end user of this product to provide an alternative, safe method of access to cater for the previously mentioned categories.

The end user should fit all necessary signage and warning notices to either side of the gate, which should be visible and clear from all directions of approach.

The product that was shipped to you was designed with a control program to protect all categories from harm or affect this however is only a safety precaution and should not be modified or tampered with by any unauthorised person not sanctioned by the manufacturer.

Please sign and date below to say that you have read and understood this notice before ANY installation work:

/     /20

### Information on using this manual



- ? Read all information thoroughly
- ? Pay attention to all safety advice
- ? Be aware of the symbols (shown above right and above left) as they have different meanings. One is an information symbol, the other a warning.
- ? There are many artists impressions of the product in this manual you should refer to the images as a guide only. **Professional CAD** drawings should be used as a reference drawing and nothing else. As before every effort has been made to be 100% accurate in this manual but we cannot make any guarantees.
- ? As we constantly innovate our products we may change the quoted spec and any other details that have been documented in this manual so you should always refer to the supplier to see if the manual that was shipped with your product is the latest edition.
- ? As with all electrical installations you should use a qualified electrician and obey all of the latest laws and regulations.
- ? Be sure to fill out and complete **ALL** paperwork where instructed as this manual is the equipments log book and maintenance manual.

The "Warnings" leaflet and "Instruction booklet" supplied with this product should be read carefully as they provide important information about safety, installation, use and maintenance.

Scrap packing materials (plastic, cardboard, polystyrene etc) according to the provisions set out by current standards. Keep nylon or polystyrene bags out of children's reach.

Keep the instructions together with the technical brochure for future reference.

This product was exclusively designed and manufactured for the use specified in the present documentation. Any other use not specified in this documentation could damage the product and be dangerous.

The Company declines all responsibility for any consequences resulting from improper use of the product, or use which is different from that expected and specified in the present documentation.

Do not install the product in explosive atmosphere.

The construction components of this product must comply with all applicable regulations and subsequent amendments. As for all non-EEC countries, the above mentioned standards as well as the current national standards should be respected in order to achieve a good safety level.

The Company declines all responsibility for any consequences resulting from failure to observe Good Technical Practice when constructing closing structures (door, gates etc.), as well as from any deformation which might occur during use.

The installation must comply with the provisions set out by all applicable regulations and subsequent amendments.

Disconnect the electrical power supply before carrying out any work on the installation. Also disconnect any buffer batteries, if fitted.

Fit an omnipolar or magnetothermal switch on the mains power supply, having a contact opening distance equal to or greater than 3mm.

Check that a differential switch with a 0.03A threshold is fitted just before the power supply mains.

Check that earthing is carried out correctly: connect all metal parts for closure (doors, gates etc.) and all system components provided with an earth terminal.

Fit all the safety devices (photocells, electric edges etc.) which are needed to protect the area from any danger caused by squashing, conveying and shearing, according to and in compliance with the applicable directives and technical standards.

This article describes how your equipment will be delivered to you, specifications on the transportation used and advice including health & safety on movement of the equipment.

The manufacturer will use a qualified transport company to deliver the product conforming to the necessary regulations as detailed below:

All drivers are qualified

All drivers are tested once yearly

All drivers carry risk assessments and method statements (available on request)

They are controlled under law to conform as there are no trade regulation standards to comply with

Health and safety Considerations:

Moving Goods Safely (MGS) is a national project involving both the Health and Safety Executive (HSE) and Local Authorities (LA) working in partnership. The project aims to reduce injuries and ill-health arising from the movement of goods from supplier through haulier to the recipient and end user including any home deliveries. The project will focus upon the delivery and collection of goods and the hazards this generates. It covers the main areas that cause the majority of injuries and ill-health to workers, including:

Workplace transport;

Slips & trips, and;

Musculoskeletal disorders (MSD).

The movement of goods presents us, as health and safety regulators, with the challenge of dealing with a huge variety of issues. The commercial organisations involved within the movement of goods are diverse including haulier, third party logistics providers, pallet networks, retailers etc, with some very large companies, thousands of small businesses and the self-employed. The movement of goods is more than just trucks on the road with a large proportion of accidents happening at the delivery/collection sites that are often not directly under the control of the company making the delivery or collection. Communication and cooperation problems can arise due to the many organizations involved in the movement of the goods, and this can also lead to difficulties in effectively managing health and safety.

(Source H&S Executive UK 2008)

The Cabinet should ALWAYS! be moved with care and attention. The products are very heavy individually as well as a whole. You should not attempt to move this or any other products by unapproved handling methods.



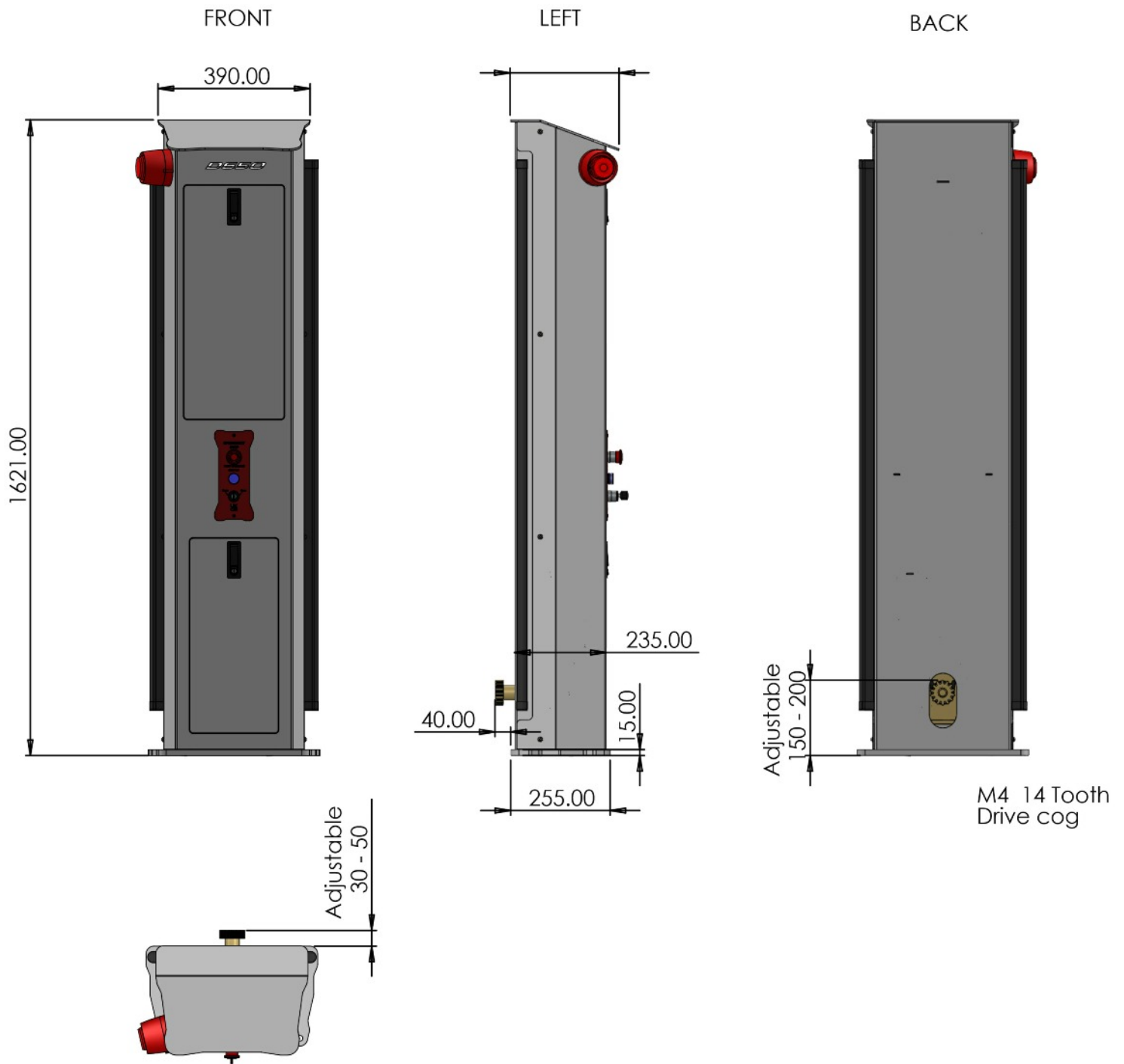

**General Layout Description.**

Please note the above dimensions are a guide based on our standard model. Should any alterations be required to cog or cabinet heights including the cogs pitch and teeth this can be requested and altered at quotation stage as per request.

The D650 cabinet is a fully functional stand alone 3 phase drive unit equipped with motor and panel ready to be installed to an existing sliding gate. The drive unit is heavy duty for a 100% duty cycle and is designed with the user and installer in mind for ease of operation and installation.

**General Layout Description cont.**

Please see exploded diagram for list and location of parts and accessories, please note this is not a definitive list, Additional options can be added. As required to suit sites needs.

The cabinet comes with a fully removable front panel for ease of access for the installer.

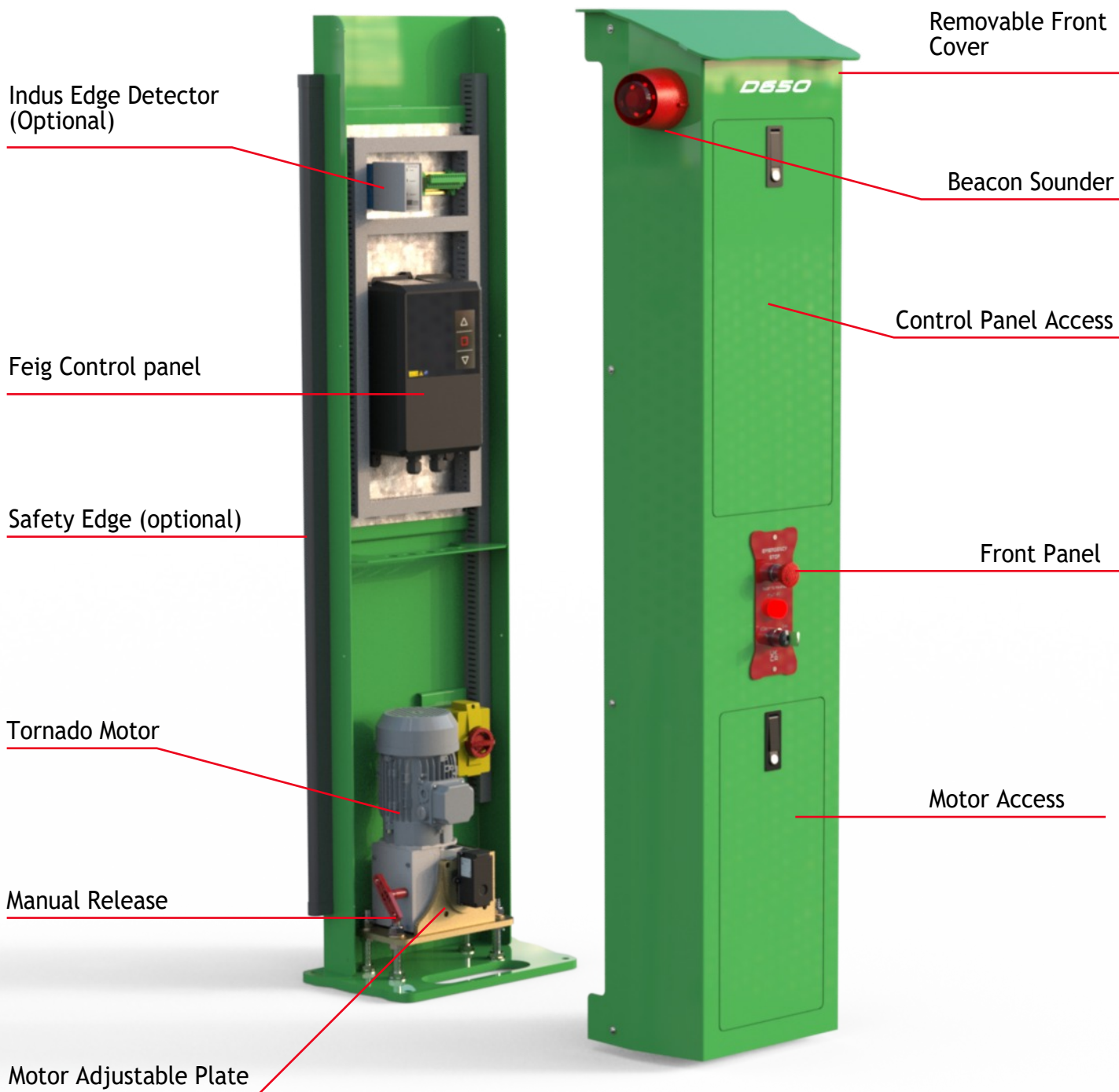



**Foundations**

The D650 is a stand alone gate automation control unit. Due to the nature and forces of this product it will require a suitable base or structure to be fixed or fastened to.

Should you install a concrete base for this to be bolted too then the following specification is suggested for all concrete poured.

We recommend a concrete mix to BS EN 206:2013+A2:2021 “Concrete specification, Performance, Production and Conformity” to type C35, which is equally suitable for external and internal environments.



The D650 is provided with a base plate which could also be fixed to a suitable structure with bolts or suitable fasteners. Please note this structure will need to be stable and strong.

**Foundations cont;**

Bellow is an example of our drive unit base plate, Please note the 4 x external holes can be used to locate your fixings. For your convenience the cabinet is also provided with a pre cut ducting location should this be required during your installation. This is the larger oval shape which will bring cables up in front of the drive motor should this option be used.

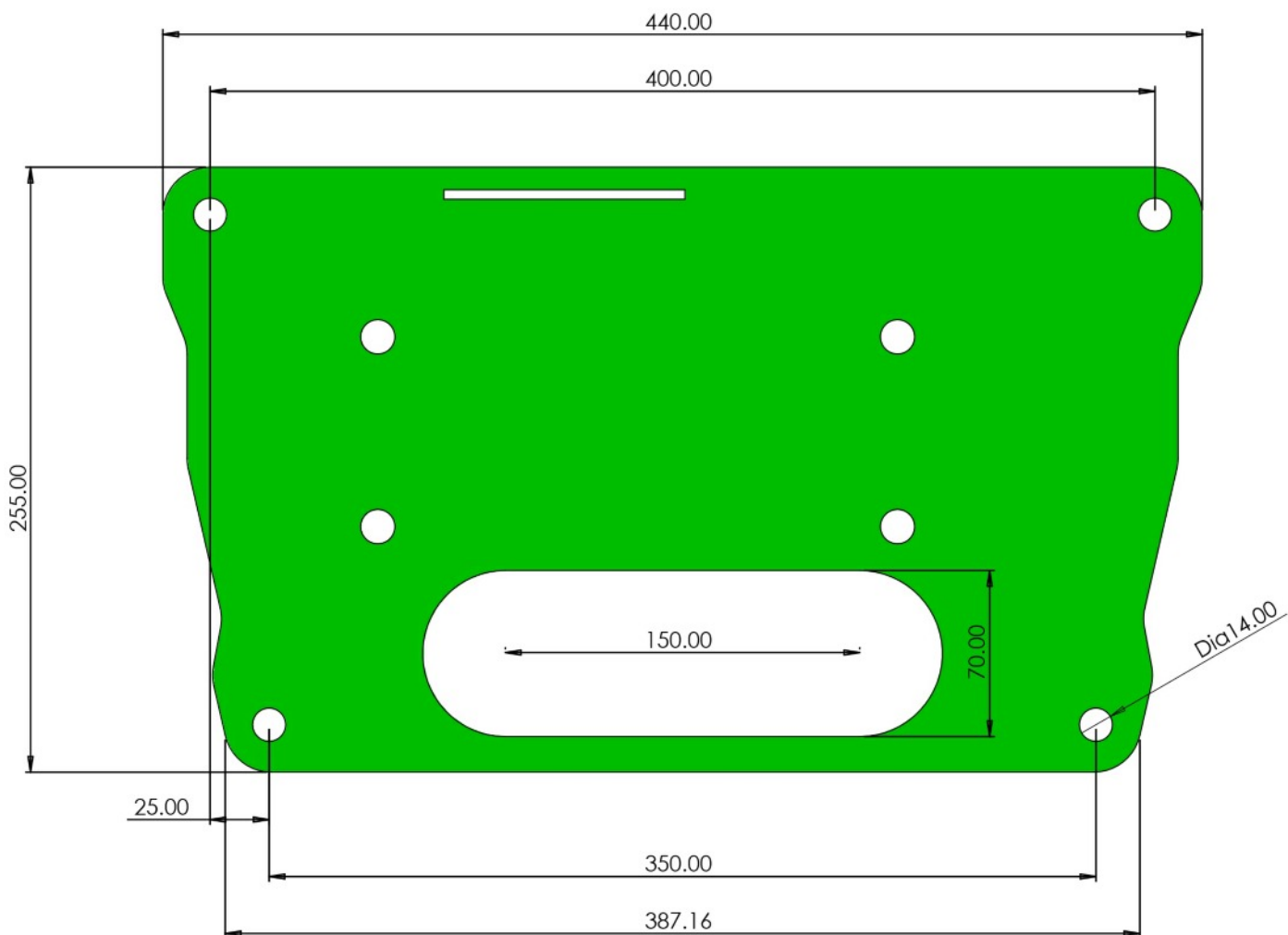

### Fixing Kits;

Once The cabinet is ready to install Please check through your fixing kit to ensure you have all bolts and accessories required. The Basic fixing kit will include;

- 1, 4 x M12 x 125mm Through Bolts
- 2, 4 x M12 Caps
- 3, Manual Release Lever
- 4, O & M Manual
- 5, Cabinet Keys
- 6, Over Ride Keys



### Please Note,

Additional items such as loop detectors, remotes, Safety edges, Indus kits and traffic lights etc can be purchased as extras at the time of quotation or by contacting our spares department and will be issued as extras in your box of fixings.

## Physical Installation.

Please note this guide assumes the installation to a concrete base.

With the cabinet lifted into position over the foundation, the following steps should be carefully followed to safely install your new gate.

### Step 1. Lowering the Cabinet onto the foundations.

Before the cabinet is lowered into position, the surface of the foundation should be swept clean of any particles or contaminants. The position of the incoming ducts to the stanchion should also be measured with reference to the foundation edges to ensure they are exactly as shown on the supplied drawing.

First you must Lower the Cabinet on to the main foundation. Whilst lowering the cabinet make sure the Ducts are aligned with the bottom Cabinet access hole.

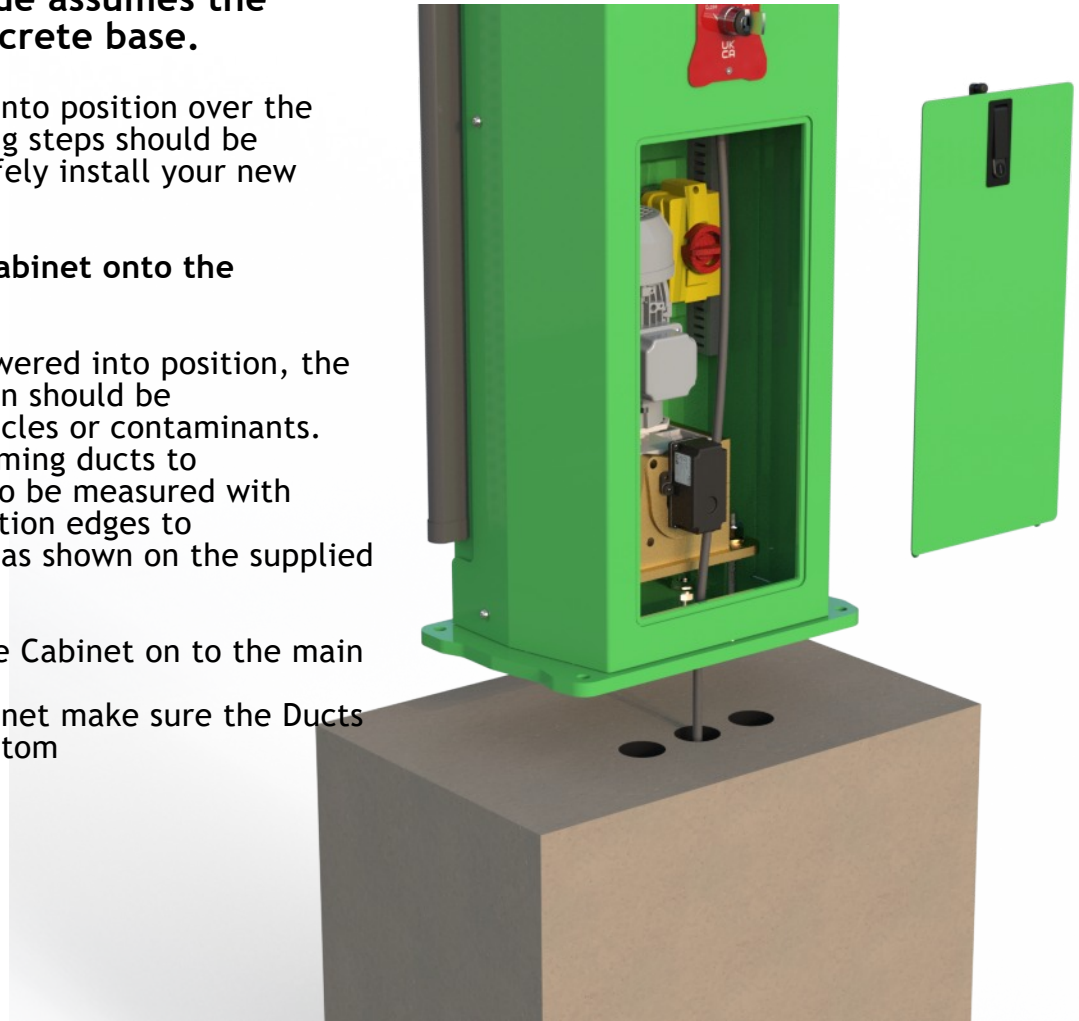

### Step 2. Adjusting the cabinets distance.

With the cabinet in position on the base every care must be taken prior to fixing the cabinet to ensure that the distance from cabinet to gate is correct. This will allow smooth operation of your gate and correct alignment with the gates drive racking.

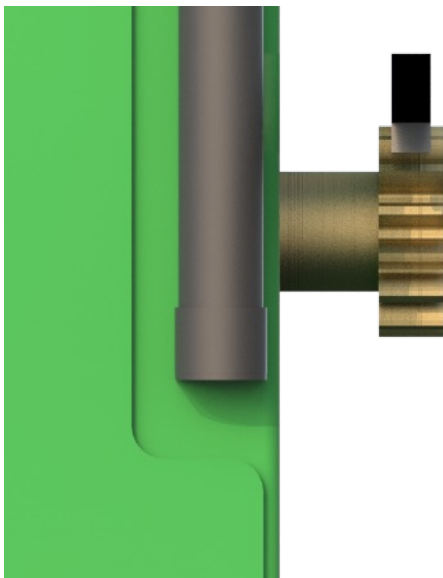

### Step 3 Fixing the cabinet.

Once you are happy with the cabinet's position the product can be fixed into place using suitable sds drill and 12mm sds drill bit. The supplied anchor fixings can then be knocked into place with a suggested copper mallet and tightened to the correct torque using an impact driver and socket or suitable 19mm spanner.

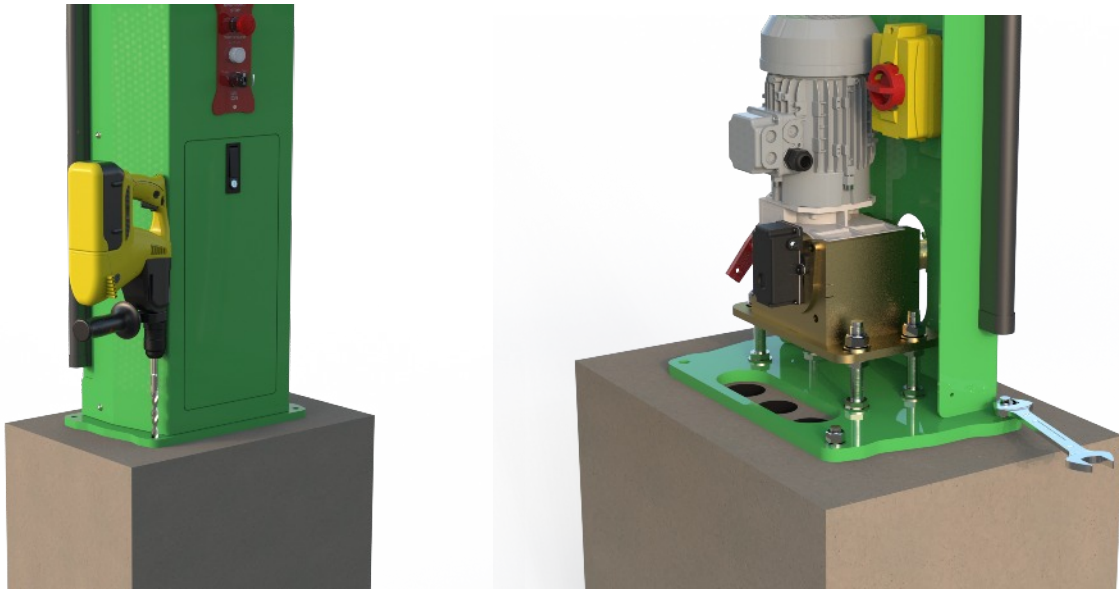

### Step 4 Adjusting the motor.

With the cabinet fully installed the motor can now be lifted inside the cabinet to suit the height of the gates racking. This can be done with a suitable 24mm spanner using the m16 nuts underneath the motor mounting plate. These can be adjusted up or down to raise or lower the motor to better suit the gate. Please note there should be a 1mm to 2mm gap between cog and drive rack.

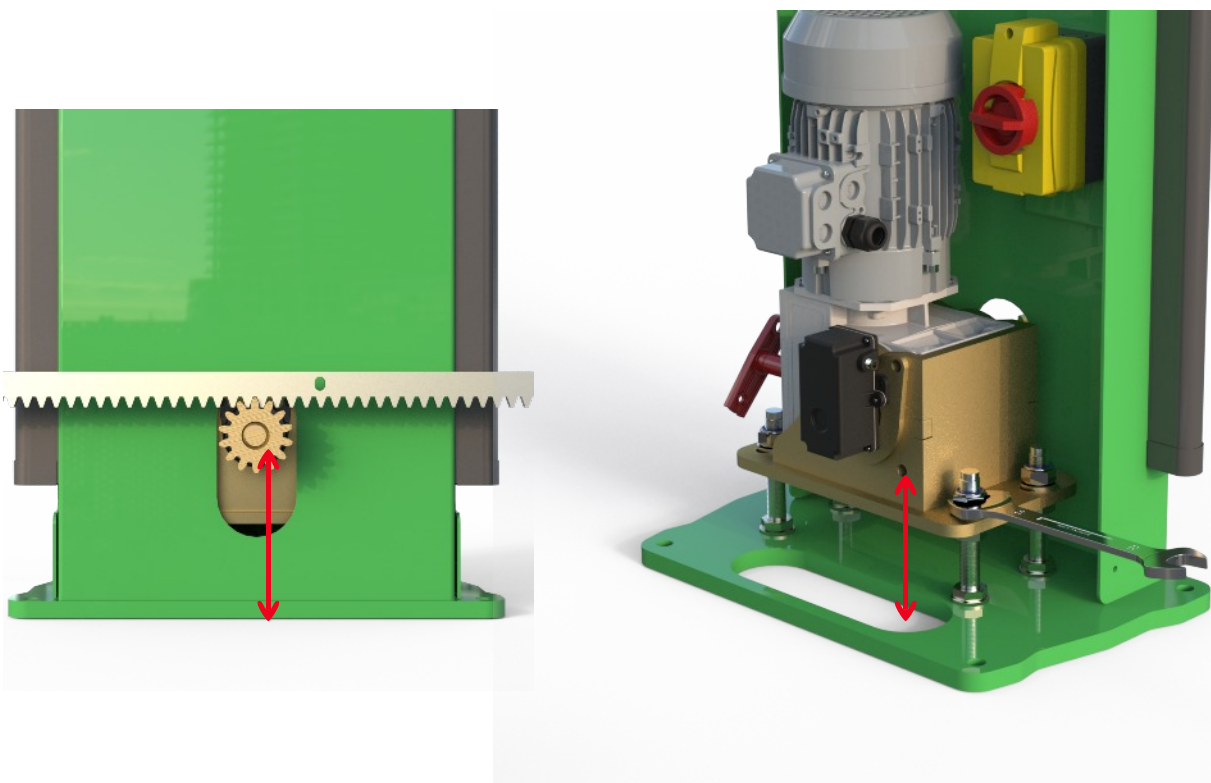

To assist in ease of installation the manual release lever can be found in your provided box of fixings. This locates onto the side of the motor and is simply turned to release or engage the drive.

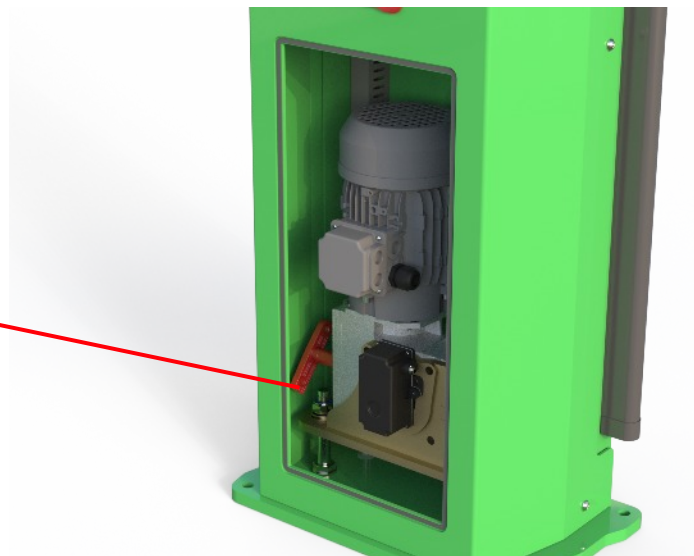

Now that your Cabinet is fully mechanically installed it is now time to connect your mains supply. This is 230 v 16 amp single phase supply.

Please Note this supply must be installed and connected by a fully qualified electrician and must confirm to BS 7671 and be fully tested to ensure minimal earth leakage. As our gates are inverter driven and the inverter itself contains earth leakage filters the supply must be connected and tested properly and installed from an mcb as opposed to an rcd. Failure to do so could result in improper function of your gate and therefore alter the gates ability to comply with all current regulations.

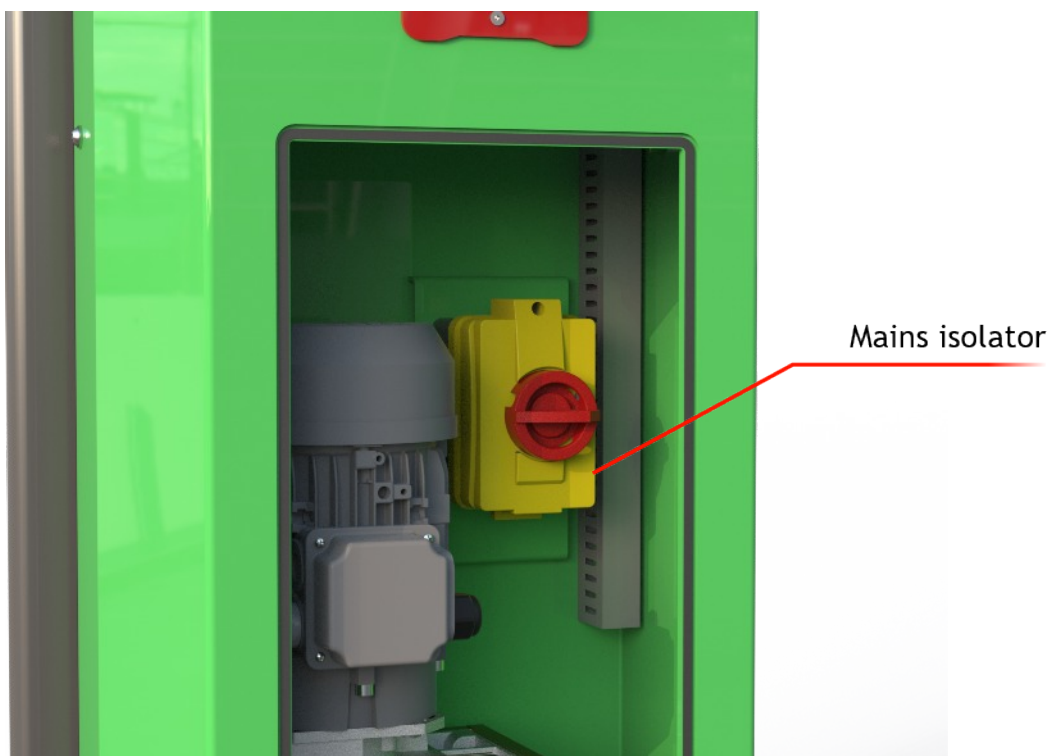



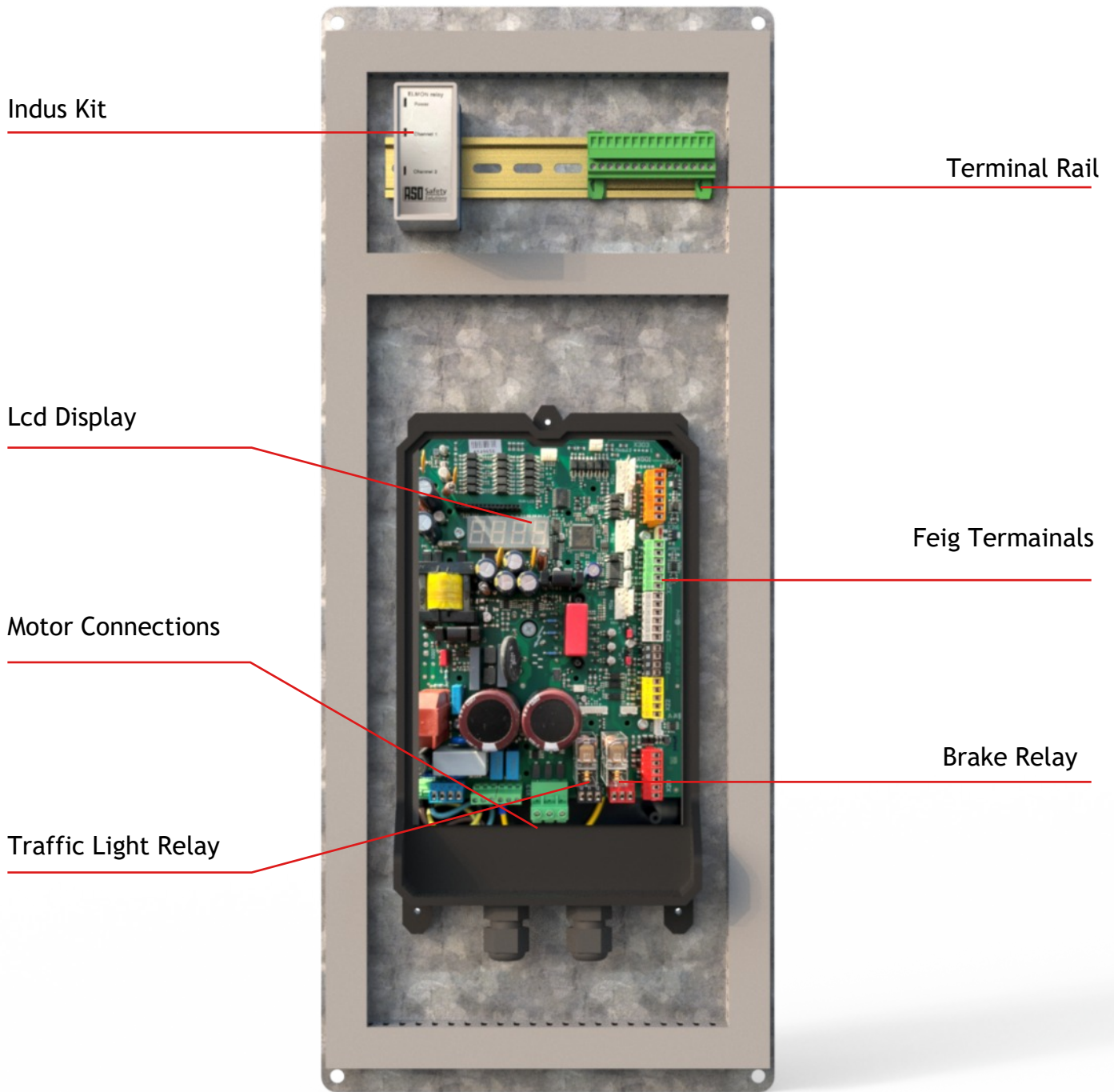

Above shows the layout of a D650 gate panel which will help identify any main components.

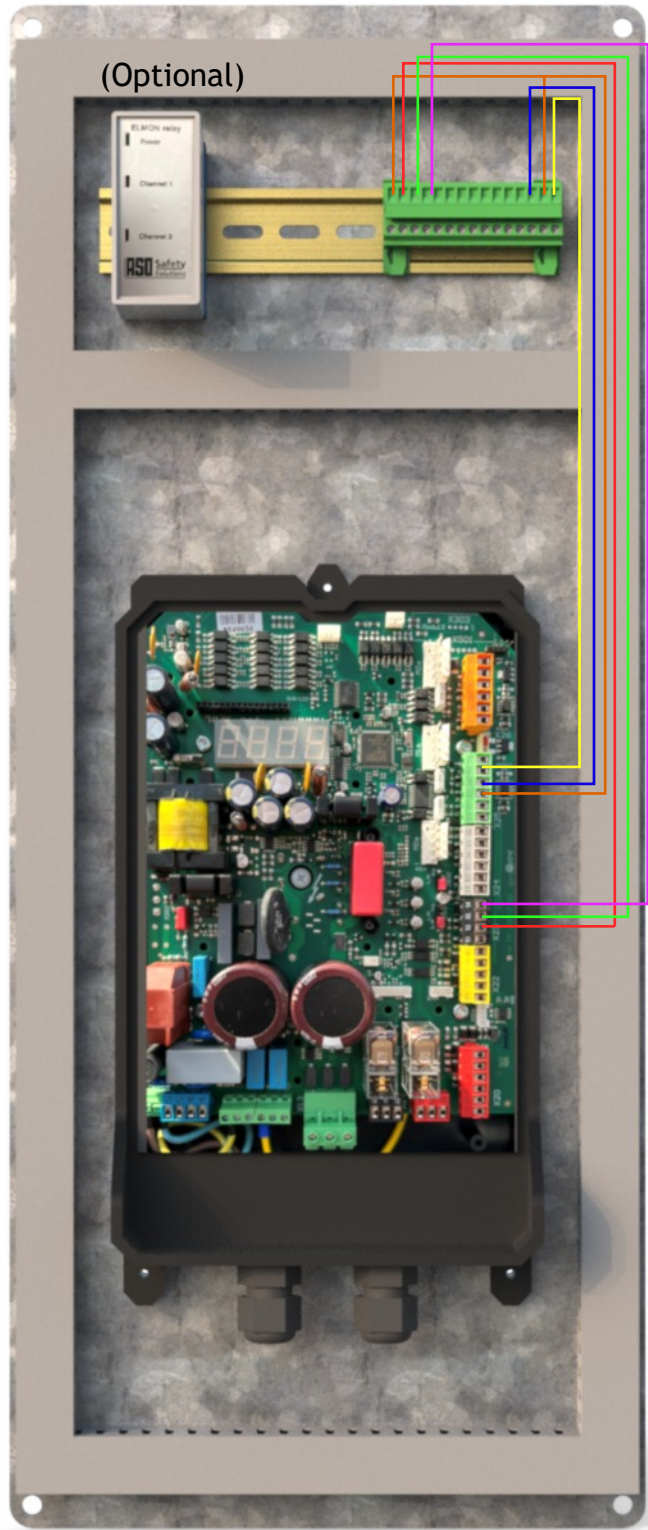

- Common +24v
- -24 v
- Photocell Contact
- Stop Curcuit
- Open Signal
- Close Signal

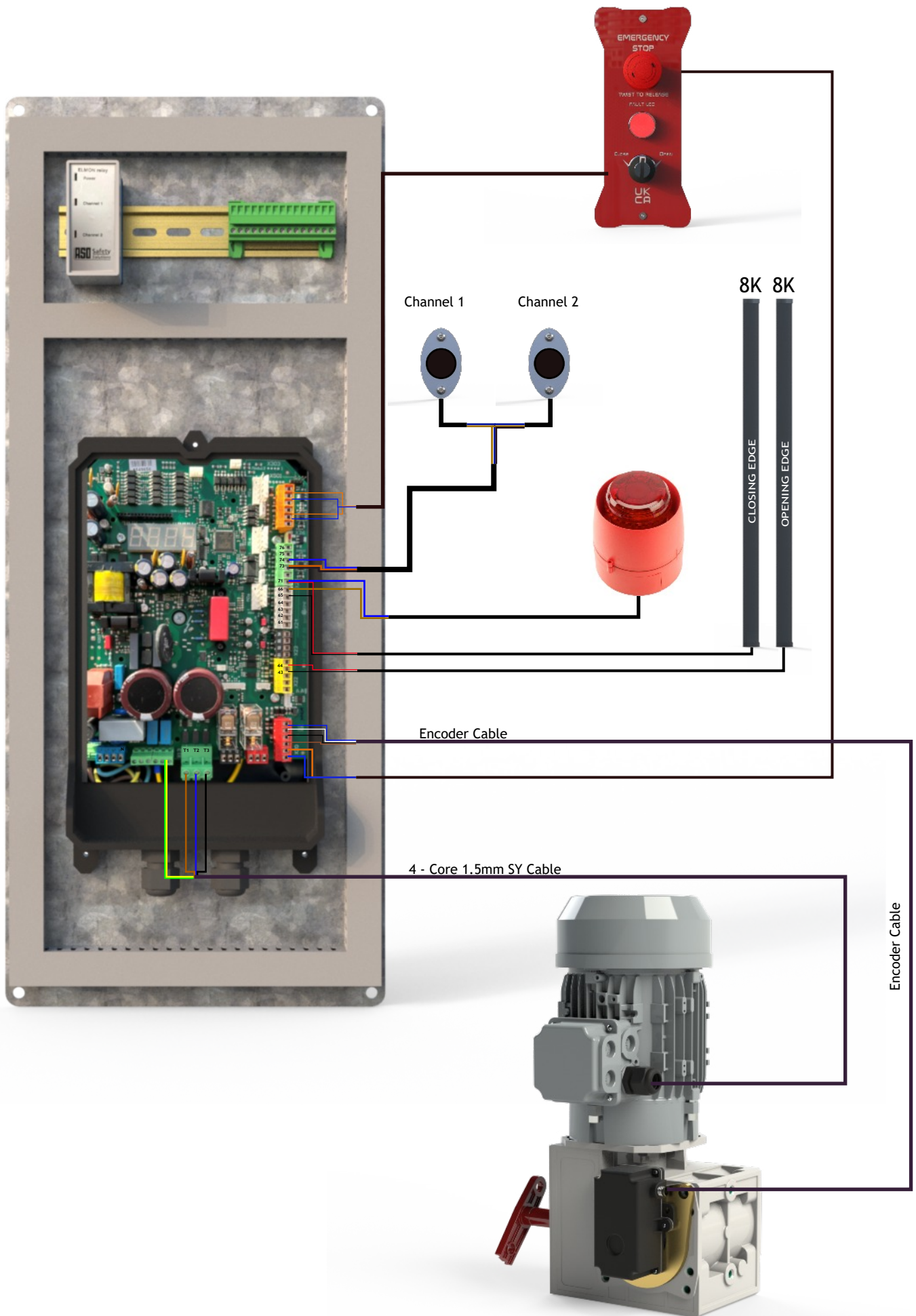



- A. Loop Channel 1
- A. Loop Channel 1
- B. Loop Channel 2
- B. Loop Channel 2
- 1. Common +24v dc
- 2. Stop N/C
- 3. Open N/O
- 4. Close N/O
- 5. Open Edge In
- 6. Open Edge Out
- 7. Close Edge In
- 8. Close Edge Out
- 9. Free
- 10. Free
- 11. Free
- 12. +24v dc (For slave photocells)
- 13. -24v dc (For slave photocells)
- 14. Photocell common (yellow)
- 15. Photocell contact (Grey)

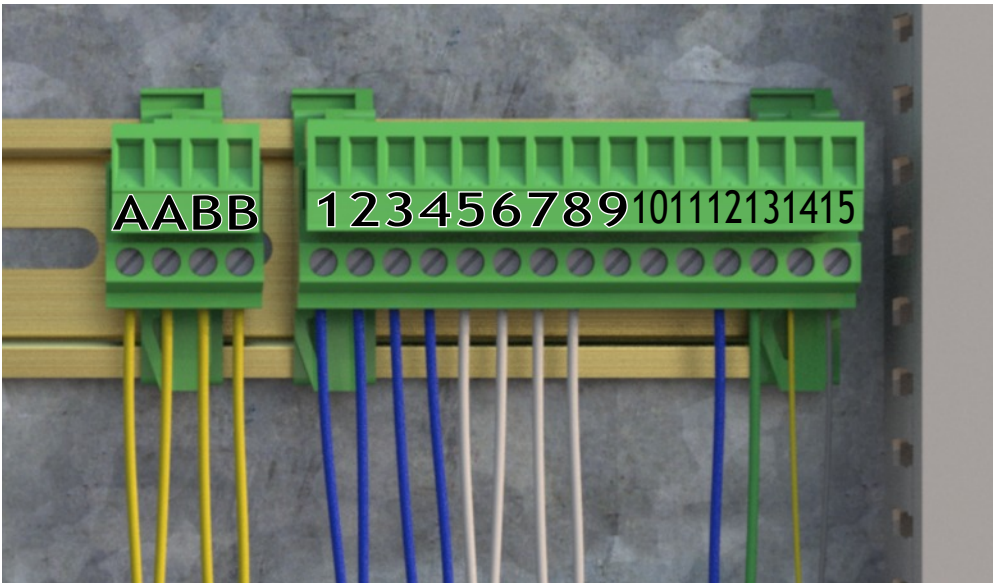

**Safety and Auto loop bases**

We now use the feig plug in loop cards for convenience of the engineer. If ordered with the product this will arrive with tails pre wired into the green terminal strip.

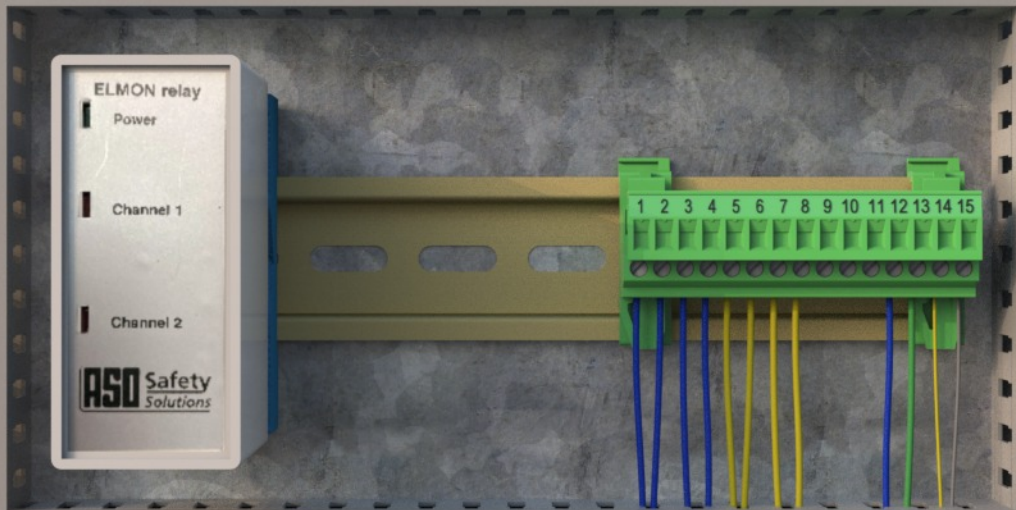

Key switch;  
From deadman open/close in board

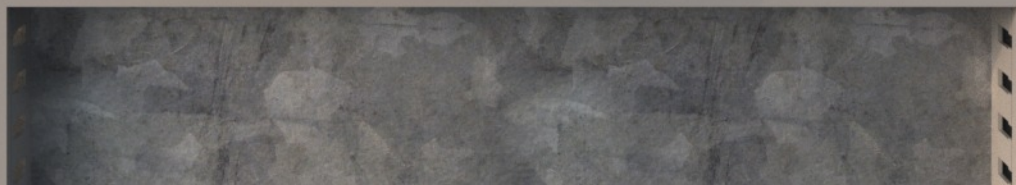

At the front of the control cabinet you will find our fully labelled door control unit this incorporates the emergency stop button which when pressed will over ride all gate functions and keep the gate stationary where activated. This can be released with a slight twist to allow operation of the gate.

In addition you can find our open / close key switch which also works with our emergency dead man function.

Please note in the event of a safety device failure the gate incorporates a dedicated dead man function.

The gate can be operated via the hold to run key switch located on the cabinet door panel simply hold in the direction you would like the gate to operate



When you have the gate powered and ready to run please follow the next few steps to initially set up your encoder run positions. This will only need setting once.

Figure 1

#### Step 1;

Once powered up provided there are no faults the board will display the message Cali, this is asking you to calibrate the encoder. Figure 1



#### Step 2;

When ready press the stop button briefly. The board will now display The EI-EC asking you to sync to close position. Note the dots between the letters will be flashing.

Figure 3

#### Step 3;

Simply hold the down arrow to close the gate to its desired position, don't worry if you let go early simply press the down to jog the gate to position. Once at your desired close position press and hold the stop until the dots stop flashing this will record the close position and then revert to the open sync, Figure 4



#### Step 4;

Please now using the up arrow move the gate to its desired open position. Again once happy press and hold the stop button until the dots stop flashing to store the open position.



#### Step 5;

The gate is now set and ready to operate, before testing safeties I would advise at this point to give the gate an open and close operation to ensure the positions are correct and you can see the slow downs and ramps operating correctly.



**Step 6,**

If you are now happy with the gates positions please test all safeties as normal, i. e all edges and photocells. The gate also now incorporates a force detection this will require a firm push to the leaf to enable its operation whilst the leaf is travelling. The leaf once force detected will move to its opposite position and stop. If The gate positions need resetting please follow the following few steps to re calibrate the encoders.

---

**Step 7,**

Should we need to reset the positions on the gate please follow these steps.

You will need to access the parameters menu. This can be done by pressing and holding the stop and up arrows together. See figure 6

Figure 6

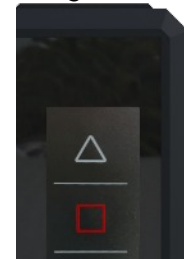
**Step 8,**

Navigate through the menu to parameter 999 (figure 7) using the up arrows. (Note holding the down arrow and pressing the up will move through parameters in blocks of ten for ease)

Figure 7

**Step 9,**

Once at P999 press and the stop button this will enter the parameter allowing you to change the value. Please set this to number 3 using the up arrows and confirm by holding the stop again for 2 seconds. Figures 8 and 9) to exit the parameter just press the stop key.

Figure 8

**Step 10,**

Now navigate through the menu to parameter 210 and set this to 5, this will reset the encoder allowing you to re calibrate the gate. Please follow previous steps until you are happy with the positions and safeties.

---

**Note** This setup is the same for single leaf and master and slave. The buttons will only work the leaf to which they are installed. To test both leaves on a bi parting gate, (double leaf) please use the open and close inputs on the board.

Parameter	Description	Timers
P010	No Passage Timer	30
P020	Open Delay Timer	0
P025	Close Delay Timer	0
P712	Traffic Light Delay	0

Motor Code	Operation	Frequency
P310	Opening Speed	Hz
P320	Opening Slow Speed	Hz
P322	Opening Ramp	Hz per second
P350	Close Speed	Hz
P360	Close Slow Speed	Hz
P362	Closing Ramp	Hz per second
P312	Open Acceleration	Hz per second
P352	Close Acceleration	Hz per second
P222	Close slow position	In Increments Of travel
P232	Open slow position	In increments of travel

### Position set up;

Should your gate run out of travel during the set up process then you will need to alter the P202 Parameter this is pre set to 8, any alterations made will double the increments of travel so 9 will be double 8, 10 will be double 9 and so on. Common practice is to have P202 set to the minimum amount achievable. The board has a maximum of around 4000 increments of travel. To alter follow the instructions previously shown to access the full menu, You will Then be able to access the 202 parameter. If in doubt the gates travel can be checked with parameter 230. This will give you the full travel increments of the gate ideally we are looking for this to be around 2000 for your pre set slow downs to be at a good distance.

3000	Increments of travel close	0
0	Increments of travel open	3000

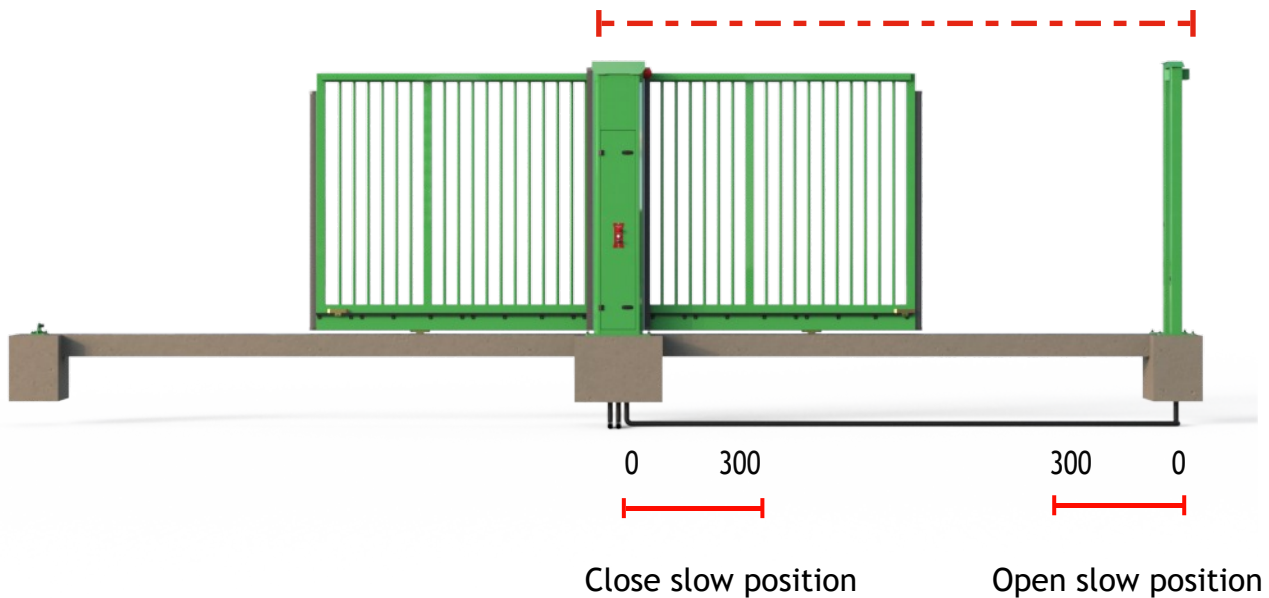

### Slow down set up;

To adjust the slow down positions Please access P222 for close slow down and P232 for open Slow down. These parameters are pre set too 300 increments from there respective limits, Therefore to reduce the slow distance 300 would be reduced for example to 200, to increase Please add to the slow down so 300 would become 400 as an example.

### Auto close options explained;

The auto close functions can be accessed through the parameters menu, For the no passage timer P010 can be easily accessed without having to access the full menu, As standard this is pre set to 30 seconds. This can be altered to your desired time in seconds, should you wish to turn this Parameter off simply set the timer to 0 which will turn the timer off.

Loop / Photocell close, To adjust the loop photocell close there are a few settings which govern this parameter. The full menu will need to be accessed, once this has been done You will need to navigate to P4B7 this parameter will be set to 0 which is off, should you Wish to turn this on set P4B7 to 2 which will enable the parameter.

Now the photo close is active we have a couple more options to add a delay to the photo close P025 can be adjusted to allow this however a delay here will also delay all close commands Therefore should you wish to give the gate a close command via access controls and this input not be delayed P535 will need to be set to 0. This will disable the timer on the close input command

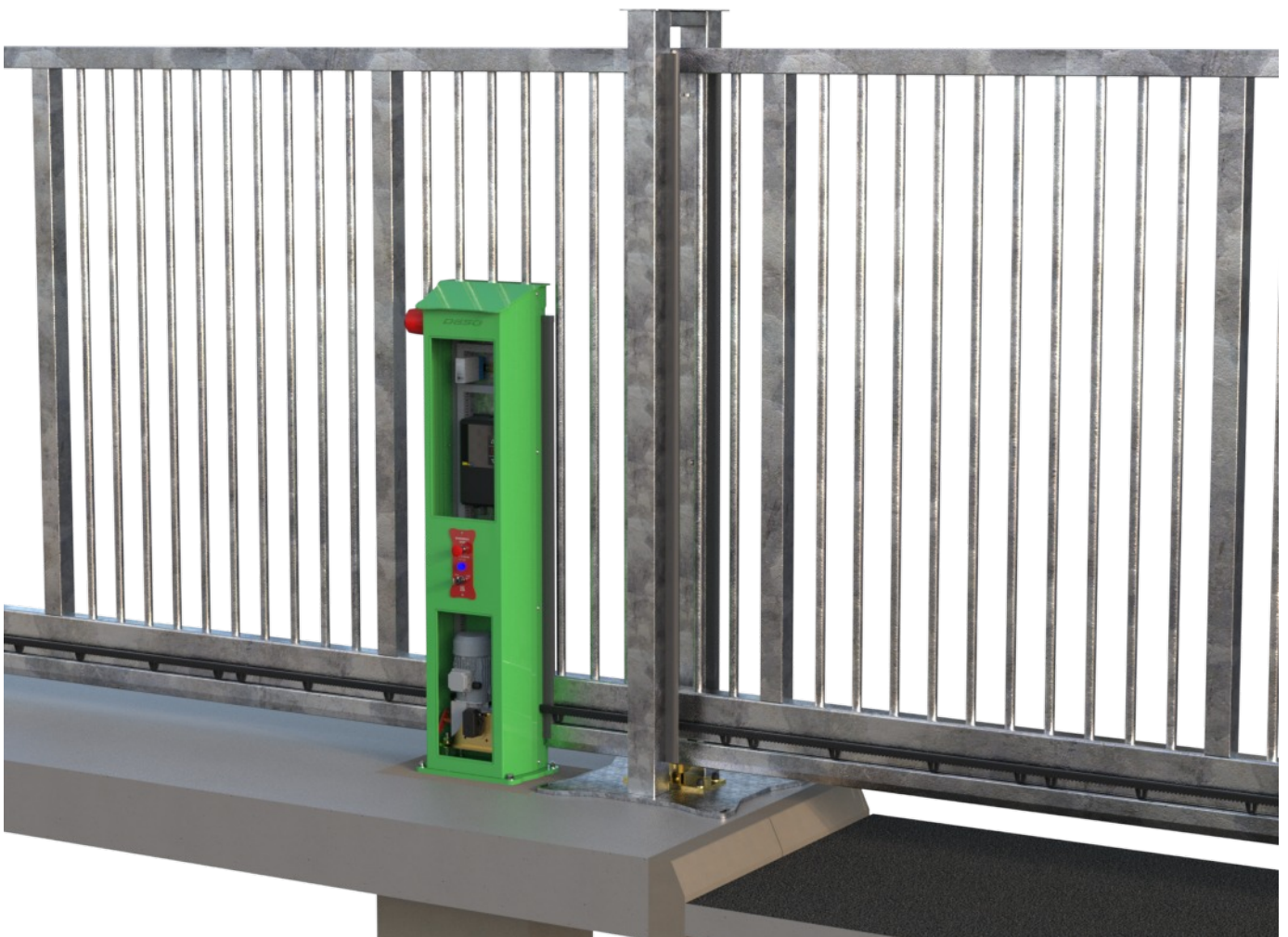

**Guide to inputs Commonly Used,**

P.100	50HZ	Motor Frequency
P.101	1.7A	Motor Current
P.102	74%	Motor Cos
P.103	230V	Motor Voltage
P.205	0800	Encoder Setting
P.202	10	Resolution/ Increments of Travel Allowed
P.216	1	Slow positions Pre-set
P.222	300	Close Slow Position
P.223	300	Open Slow Position
P.310	30HZ	Open Speed
P.312	100	Acceleration Open HZ per second
P.320	10HZ	Open Slow Speed
P.322	15	Open Ramp
P.332	500	Deceleration After Opening Edge Activation
P.350	30HZ	Close Speed
P.352	100	Acceleration Close HZ per second
P.360	10HZ	Close Slow Speed
P.362	15	Close Ramp
P.372	500	Deceleration After Close Edge Activation
P.420	3	Pause Time on Safe Edge Reversal M/S
P.70F	0801	Output 15 Set to Beacon Sounder

**Closing Edge,**

P.460	1	8K2 Edge
P.467	16	Reverse Increments During Closing according to P.4xB
P.4DB	400	Reversal Increments

**Opening Edge,**

P.5A0	14	Input 10 Safety A
P.5A1	10	Reverse Increments During Opening according to P.4xB
P.5A2	2	Input 10 8K2
P.4AB	400	Reversal Increments

The loop board can be added to your Feig controller as per the diagram these simply push in for ease and allow easy control for single or dual channel.

L.E.D Indications

- Green fast flash - Detector Tuning
- Green Solid Light - Detector is ready
- Green and Red on - Loop detecting
- Red Solid Light - Loop Fault

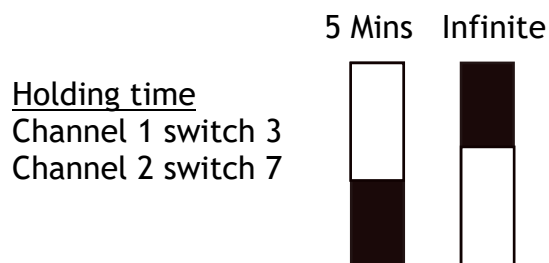
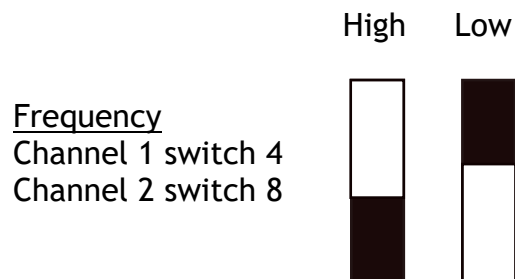
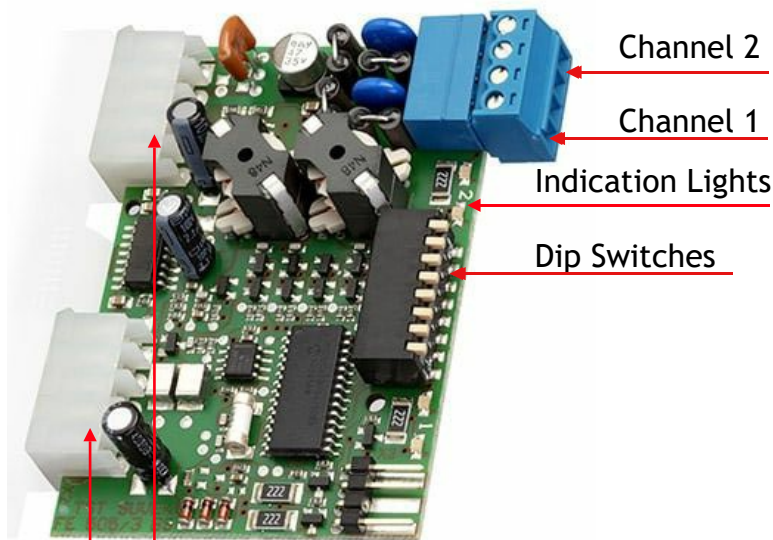

Dip switches 1 and 2 for sensitivity loop 1  
Switches 5 and 6 loop 2

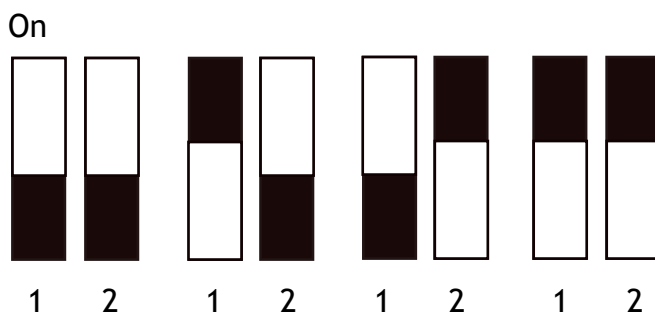

The loop card when used must be activated this is done by changing up to three parameters on the feig controller depending on the application and functionality of the loops to be installed.

- P.802 - 0302 This activates the loop card.
- P.660 Channel 1 -
- P.670 Channel 2 -
- 23 This activates the safety function of the loop card.
- 22 This activates the free exit (open signal) from the loop card.
- 20 Turns the parameter off

If master slave or double leaf the 660 and 670 parameter will need changing on both panels.

In the event of a power failure or electric fault you can manually release the gate and to enable you to be able to open and close the gate by hand.

In order to do this you must first make sure the power has been isolated, then you need to gain access to the control cabinet using the keys supplied and pull the release handle as shown below.

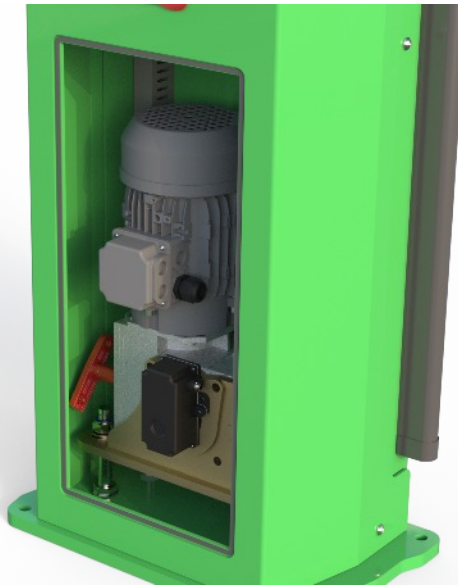

Place the release handle supplied on to the shaft to the side of the gearbox as shown above.

Then turn anti-clockwise to release the gearbox which will allow the gate to free wheel. Then turn the handle clockwise to tighten to put the gate back into automatic.

**Make sure you have control of the gate whilst it is in free wheel, the gates are designed to free wheel very easily and can be operated by one person however great care should be taken to ensure no damage is caused when pushing the gate in manual mode. Once you are done turn the red handle lock the motor back in to normal mode.**

Note, When powering the gate back up and putting back into use it is advisable to do this when the gate is in the fully opened position so that it knows where it is for its first operation.

**Caution** - The supplier will take no responsibility for any damage that is caused by misuse of manually using the gate.

Code	Description	Reason
E000	Open pressed Membrane	
E050	Stop pressed Membrane	
E090	Close pressed Membrane	
E101	Open input	Open activated
E102	Stop input	Stop activated
E103	Close input	Close activated
E104	Ped open Input	Ped activated
E105	Photocell input	Photocell activated
E106	Dead open input	Deadman open activated
E107	Dead close input	Deadman close activated
E108	Open limit input	Open limit activated
E109	Close limit input	Close limit activated
E110	Input 10	Open safety input loss of 8k
E201	Membrane stop pressed	
E211	E-stop	Terminals 41/42 open
E212	E-stop	Terminals 31/32 open
E360	Close edge input	Terminals 43/44 open
E363	Close edge resistance	Terminals 43/44 no 8k
E380	Open edge input	Terminals 63/65 open
E383	Open edge resistance	Terminals 63/65 no 8k
E501	Loop detector channel 1	Channel 1 active
E502	Loop detector channel 2	Channel 2 active

Code	Description	Fault / Rectification
F000	Traveled Past calibrated open	Check Speeds/ Encoder Slip / Re-calibrate
F005	Traveled Past Calibrated open	Check Speeds/ Encoder slip / Re-calibrate
F020	Run Time exceeded	Check P410/P415/P419
F030	Lag Error	Check Boost settings P.140 / P.145
F031	Moving wrong direction	Channel A/B reversed. Recalibrate p210
F211	E-Stop	Terminals 41/42
F212	E-Stop	Terminals 31/32
F325	Obstacle During Closing	Adjust force detection settings
F360	Closing edge activated	Edge detected terminals 43/44
F363	Interruption closing edge	Check for 8k input
F380	Open edge activated	Edge detected terminal 63/65
F383	Interruption open edge	Check for 8k input
F425	Overvoltage Supply	Incoming mains voltage too high
F426	Undervoltage Supply	Incoming mains voltage too low
F430	Heat sink temp out	Power stage too high
F515	Motor Overcurrent	Boost settings too high, P140/P145
F700	Position Unknown	Calibration not set or recalibrate P210 to 5
F752	Loss of Comms with Encoder	Interface cable defective/No 12v supply
F766	Encoder Error	Re-calibrate P210-5
F76A	Encoder Magnetic Field	Re-fit magnet further into encoder
F7A2	Expansion Board error	Loss of comms master/slave
F930	External watchdog error	Moisture on board / Hardware error

MECHANICAL ERRORS	CAUSE	CORRECTION
Gate keeps overtravel	Encoder position	check calibration and re calibrate as required
Gate creaking when moving	Check gate rollers	Replace as necessary
Gate motor not running	Loss of voltage	Check motor supply test 3 phases
Gate not opening or closing	Safety issue	Call service team to diagnose fault
Gate not opening or opening half way	Increments incorrect	Check p202 and raise number by 1
Gate opens slowly and closes too quickly	Slow positions not defined correctly	Contact installer to re-commission
Gate not running at all	Motor in manual operation	Check manual release and turn as required
Gate open will not close	Key switch is left in open position	Turn key switch to auto
	Loop fault or loop detecting	Check if red light is on detector if so remove object that it is detecting or replace loop
ELECTRICAL ERRORS	CAUSE	CORRECTION
Blank screen on lcd but power to other devices in the control panel	On-board fuse blown or short	Unplug accessories / Replace fuse
	Lcd has developed an electrical fault or had a power spike	Change control panel
Gate does not run (stays open)	Check Controller for error code	Locate issue as appropriate to code
	Loop detector is faulting or sensing presence	Clear obstacle / reset the detector
	Check Photocells power	24vdc or 3.6v Batteries to replace
	Gate staying up in open position	Open signal latched from access controls
	Photo cells dirty (if fitted)	Clean photo cells make sure they are debris free
	Stop circuit broken	Check door button/access controls
Mains on but no power	Isolator fuse	Check and meter fuse in isolator
Gate not opening up	Access control may be faulty	Raise and lower barrier from buttons on
	Door switches poor contact	Remove and re-fit switches

Your Gate will conform to BS EN 12453:2017 the standard for powered machinery and any additional amendments to this critical safety standard. We manufacture gates and equip them with safety and other options, only to the extent specified by our customers. Therefore, the gates, as delivered, may not represent a complete machine as defined by the regulations. As such, the addition of any after market safety devices by the client must conform to this standard as well as BS EN 12978:2003+A1:2009 the standard for sensitive safety devices. The three main points of covered in this standard are the installation, design and elimination of hazards and electrical control system integrity also the Implementation of devices designed for safe contact (force limitation) such as resistive safety edges. The standard also covers Non Contact (presence detection that prevents hazardous contact) such as and not limited to, photocells, light curtains, radar sensors and inductive loops.

It is imperative that the installer carries out an onsite risk assessment prior to fitting or maintaining the gates, and a residual risk assessment once the installation is complete. These will highlight any remaining safety issues, and allow the installer to fit additional equipment or draft suitable protocols for operation of the equipment. Therefore the product must be installed and maintained by a competent, qualified and well trained company or individual.

As standards are ever improving the safety devices and systems in use may need to be upgraded from time to time. The standards will always refer to 'state of the art' safety devices being used in conjunction with the product. However the emphasis is always preferred on non contact devices with the back up of sensitive (force detecting products also).

To add additional safety products and accessories to an existing product the relevant paperwork and Declaration of incorporation (or Certificate of Compliance as appropriate) must be updated and kept for the relevant standards to be adhered to.

All Electrical supplies to gates and machine products must be installed to the correct Standard i.e. the current edition of BS 7671:2018+A3:2024 and any alterations to this supply must be recorded and adhere to this standard. These can be recorded in the Electrical installation Certificate or the Periodic Inspection report.

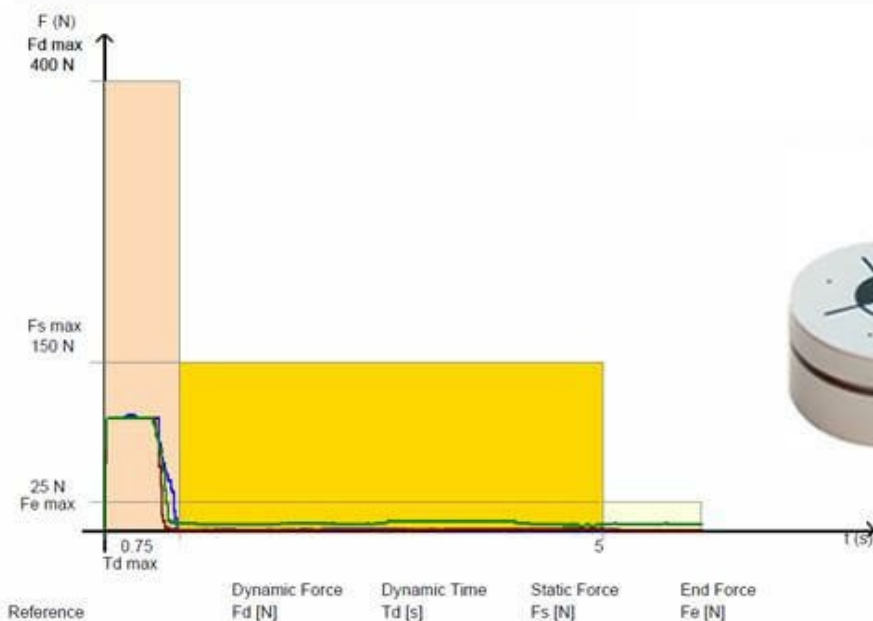



As stated at the beginning of this manual we recommend a bi-annual service, but at a bare minimum, it is imperative that you get a service done once every 12 months. This is not a sales tactic in disguise, there is a very serious health and safety issue/risk associated with not complying to this. Also in order for your gate to keep complying with the appropriate legislation.

Before carrying out any maintenance to the installation, disconnect the mains power supply.

Make sure you have disconnected/Isolated the power before attempting any work.

A Maintenance Contract should be sought from a specialist company after a maximum of 5000 manoeuvres or 1year from the install date.

Occasionally clean the photocell optical components and make sure they are free from dirt, water, rain, soil etc.. ? Batteries in photo cells may need to be changed every 6 months or sooner dependant on use. The gate will not work properly without photo cell function.

Have a qualified technician (installer) check the correct setting of the electric clutch.

If the power supply cable is damaged, it must be replaced by the manufacturer or its technical assistance service, or else by a suitably qualified person, in order to prevent any risk.

When any operational malfunction is found, and not resolved, disconnect the mains power supply and request the assistance of a qualified technician (installer). When automation is out of order, activate the manual release to allow the opening and closing operations to be carried out manually.

Gearbox drive unit is “sealed” for life and requires no further lubrication.

Parts that require lubrication -

The gate has a drive rack that needs lubricated with a DW40 type lubricant.

On a annual service these items mentioned above should be lubricated as well as all other checks listed below.

Checks on a service -

- All safety edges are operational
- All photocells are operational
- Limit switched are set correct
- Gates are structurally ok e.g no damage
- All connections/wiring are ok
- All push buttons and stop circuits operate correctly

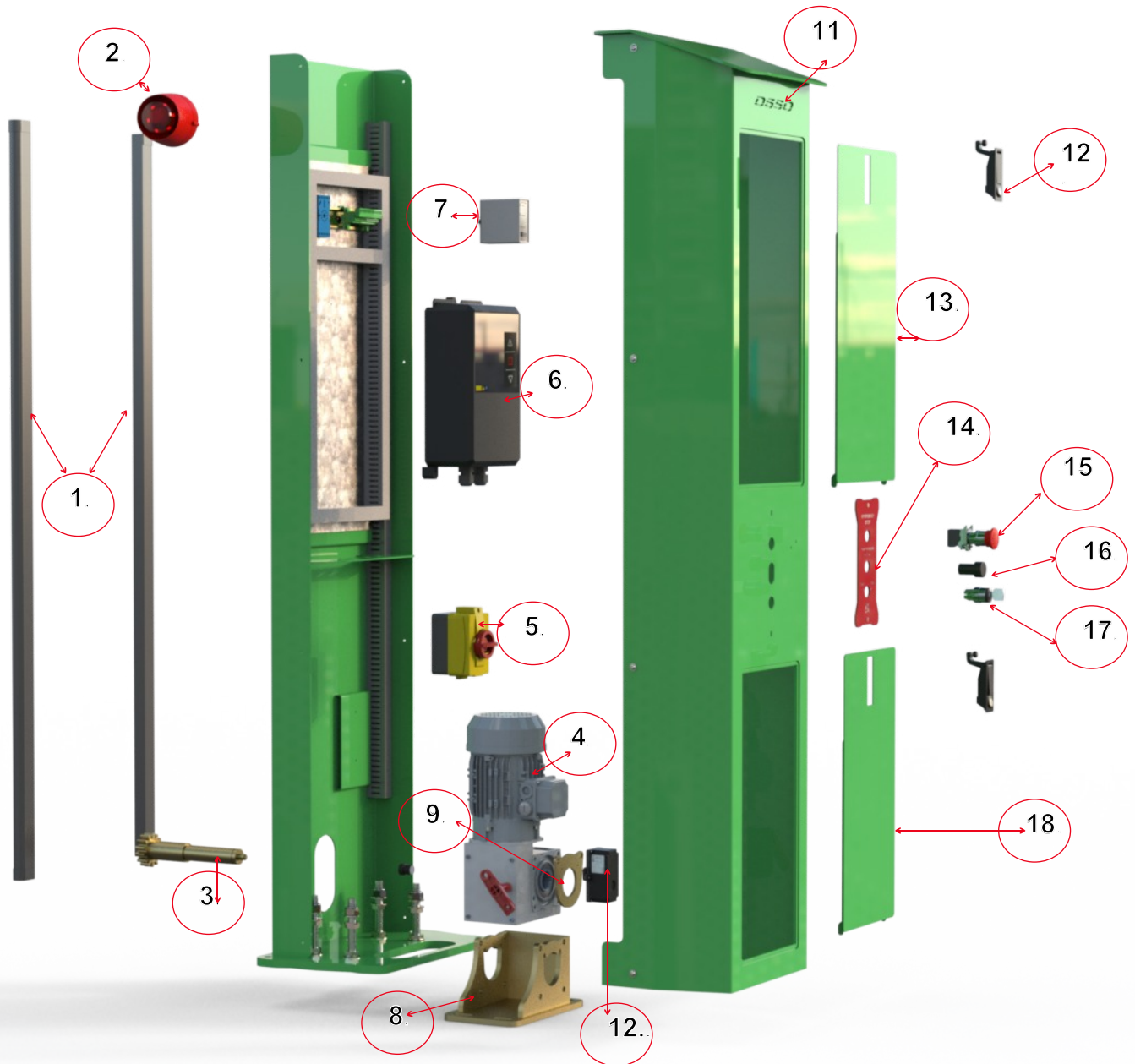

- |                       |                         |
|-----------------------|-------------------------|
| 1. Safety Edge        | 10. Encoder             |
| 2. Beacon Sounder     | 11. Cabinet Front       |
| 3. Tornado Shaft      | 12. Cabinet Lock        |
| 4. Tornado Motor      | 13. Panel Door          |
| 5. Rotary Isolator    | 14. Panel Perspex       |
| 6. Feig Control Board | 15. Emergency Stop      |
| 7. Indus kit          | 16. Fault Light         |
| 8. Motor Plate        | 17. Key Override Switch |
| 9. Encoder Bracket    | 18. Motor Door          |



This Manual **must** be completed in accordance with the guidelines below, **at any point** service/repair work is carried out on the product. This is to achieve two things;

1. To keep a history of the product for yourself and your supplier/manufacturer.
2. To keep an accurate log of any historical or recent modifications, and/or problems, to help an engineer in the event of any future work required on the product.

Date	Reason for visit/Action taken	Engineers Signature
/ /20		
/ /20		
/ /20		
/ /20		
/ /20		
/ /20		
/ /20		
/ /20		
/ /20		
/ /20		
/ /20		
/ /20		
/ /20		
/ /20		
/ /20		
/ /20		
/ /20		
/ /20		
/ /20		

We certify that the system covered by this certificate has been commissioned satisfactorily.

Site Name		Completion	
Site Reference		Engineers Installing	
Installation Commenced	/ /	Commissioning	
Equipment Fitted			
Handover Date			

Part 2. Existing Installation Items not covered under warranty/ This certificate:

Part 3. Certificate Signing off

Installers Name		Signature	
On Behalf of		Date of Signing	
Address		Position	
Client Name		Signature	
On Behalf of		Date of Signing	
Site Address		Position	

Part 4. Onsite training for product usage

Trainers Name,	Date	Competency / Job Title	Signature
Attendees Name	Date	Signature to confirm understanding	



Ultimation Direct Ltd  
Maltkiln Lane, Newark, Notts, NG24 1HN

Tel: 01636 550300  
Email: [enquiries@ultimationdirect.co.uk](mailto:enquiries@ultimationdirect.co.uk)

## Declaration of incorporation

In accordance with BS EN ISO/IEC 17050-1:2010

**We:** Ultimation Direct Ltd

**Of:** Trent Lane, Maltkiln lane, Newark, Notts NG24 1HN In

accordance with the following directives:-

Supply of Machinery (Safety) Regulations 2008

Electromagnetic Compatibility Regulations 2016

The Radio Equipment Regulations 2017

Hereby declare that:

**Equipment:** Automated Sliding Gate Drive

**Model no:** D650

Are in conformity with the applicable requirements of the following documents:

Supply of Machinery (Safety) Regulations 2008.

BS EN 12453:2017+A1:2021 Industrial, commercial and garage doors and gates—Safety in use of power operated doors— Requirements.

BS EN 12604:2017 Industrial, commercial and garage doors and gates—Mechanical aspects—Requirements and test methods.

BS EN 13241:2003+A2:2016 Industrial, commercial and garage doors and gates - Product standard. Products without fire resistance or smoke control characteristics.

BS-EN12978:2003 Industrial, commercial and garage doors and gates. Safety devices for power operated doors and gates. Requirements and test methods.

BS EN 13856-2:2013 Safety of machinery. Pressure sensitive protective devices. General principles for the design and testing of pressure sensitive edges and pressure sensitive bars.

I hereby declare that the equipment named above has been designed to comply with the relevant sections of the above referenced specifications. The unit complies with all applicable Essential Requirements of the Regulations.

Signed:

A handwritten signature in black ink, appearing to read 'Matthew Mulholland', is written over a horizontal line.

Name: Matthew Mulholland

Position: Technical Director

Place: Newark

Date: March 2026

The UKCA logo consists of the letters 'UK' stacked above 'CA' in a bold, black, sans-serif font.

**Specification**

Maximum Gate Weight: 3.5 Tonne  
 Power Requirement: 230v, Single Phase, 50Hz, 16 Amps  
 Drive Motor: 3 Phase motor & wormed gearbox  
 Opening/Closing time: 3.6 seconds per metre at 50hz (variable)  
 Duty Cycle: 100% continuous duty rating  
 Finish: Powder Coated

Control: Feig control panel

**Motor/Gearbox**

BA 52- 25,03 combination gearbox Motor  
 power :- 0.55 kw  
 Voltage :- 230 V / 3 ph / 50 Hz  
 Ratio :- 15 : 1  
 Output speed :- 2770 rpm  
 Output torque :- 550Nm  
 Hollow bore :- 30mm

Dimensions



**Made in the UK**

